

RFA Loopback Setup for 3.0T with Dual-Drive RF Amplifier – **bodydummy** (Agilent RF power measurement kits)

Landmark:

One foot from head end of empty table.

NOTE:

If monitoring Ch1, use cable going to J14 and disconnect and set aside cable going to J21. If monitoring Ch2, use cable going to J21 and disconnect and set aside cable going to J14.

*For DPP systems: Set attenuation to 20 dB.

Connect the system cable to re-route box J7 or RFSBv1 B1 (normally connected to combiner J11, below).

For DPP systems: Connect the system cable to Rx Dist J13 (normally connected to combiner J11, below).

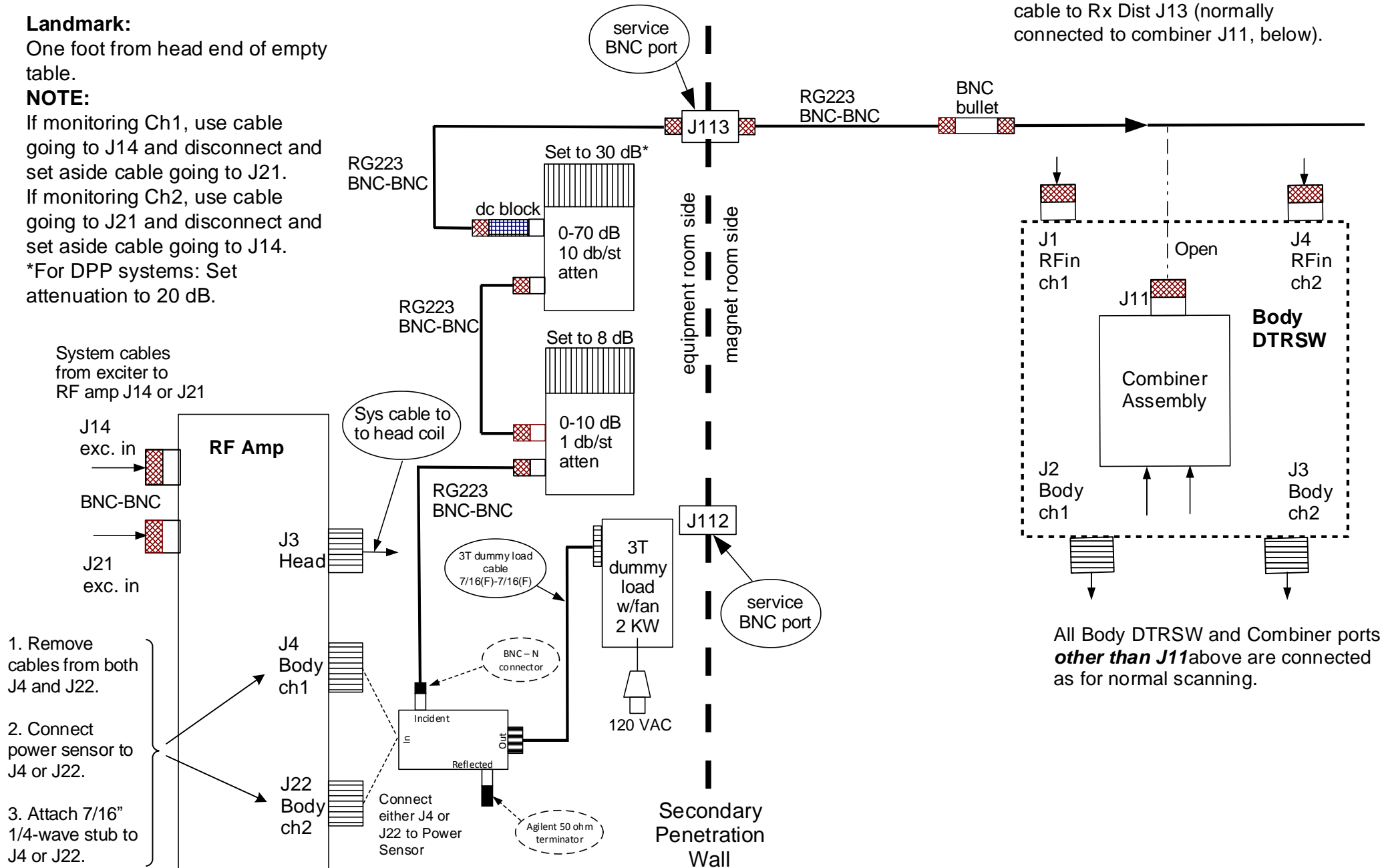

System cables from exciter to RF amp J14 or J21

1. Remove cables from both J4 and J22.
2. Connect power sensor to J4 or J22.
3. Attach 7/16" 1/4-wave stub to J4 or J22.

If cables to both J14 and J21 remain connected, then two dummy loads must be used and each Body Ch1 and Ch2 output must be connected to a dummy load.

All Body DTRSW and Combiner ports **other than J11** above are connected as for normal scanning.