

IS THIS THE LATEST REVISION OF THIS DOCUMENT

Before proceeding, please verify that you are using the latest approved revision of this document. To do this you may check with your Document Control Administrator. If you are not sure how to do this, please ask your team leader or manager.



**SIGNALITE AND HDe PATIENT TRANSPORT**  
**MAINTENANCE MANUAL**



Approved and Reviewed by: <b>Anand K</b> Author: <b>Kiran Kumar M R</b>	Date: 11/Nov/06  Date: 14/May/20(Rev-7)	<b><u>SIGNALITE AND HDe PATIENT</u></b> <b><u>TRANSPORT</u></b> <b><u>MAINTENANCE MANUAL</u></b>			
This document is the property of GE Medical Systems. It can be neither reproduced nor communicated to a third party without written permission from a specially mandated person from the company.		Number	Type	Format	Sheets
<b>GE Medical Systems – MR engineering</b> <b>Bangalore - India</b>		<b>2387327</b>	<b>TPH</b>	<b>A4</b>	Page 1 of 30
					Rev   7

**PLANNED MAITENANCE LOG**

	<b>PATIENT TRANSPORT</b>	<b>TYPE</b>	<b>A</b>	<b>B</b>	<b>C</b>	<b>D</b>
1	Check Emergency Release of Cradle and Patient Transport	1	X		X	
2	Check Patient Transport Docking and Alignment	3		X		X
3	Check Patient Transport Casters and Armboard Set Screws & Bumpers	1	X		X	
4	Check Patient Transport Caster Locks	1	X		X	
5	Check Cradle Longitudinal Drive Clutch	1		X		X
6	Check Patient Transport Hydraulic Filter	3	X		X	
7	Clean Lightweight Cradle Wheels	3	X		X	
8	Check the spring boosters	3	X		X	
9	Check down time/down release cable slackness	3		X		X
10	Cradle home/table down interlock adjustment	1		X		X
11	Cradle release PIN height adjustment	1		X		X
12	Cradle side Lock	1		X		X

**Type 1 – Safety and Regulatory**

**Type 2 – Image Quality**

**Type 3 – Other (System available for patient scans)**

**Type 4 – Other (System available for patient scans)**



**WARNING!!**

**IF PM PROCEDURE INDICATES FURTHER MAINTENANCE IS REQUIRED, REFER TO THE APPROPRIATE TECHNICAL MANUAL BEFORE PERFORMING ANY FURTHER MAINTENANCE. MANY PROCEDURES REQUIRE PRECAUTIONS TO BE TAKEN TO AVOID PERSONAL INJURY OR DAMAGE TO EQUIPMENT.**

**Rev: 7 (14 May 2020)****Doc No.2387327**

<b>Rev</b>	<b>Date</b>	<b>Author</b>	<b>Change</b>	<b>Description</b>
1	23/01/2004	Narendar.v	-	Rev1 Release
2	07/03/2005	Narendar. V	-	Section 11 added.
3	10/11/2006	Kiran	Revised	HDe Table Added and Sections updated
4	04/01/2008	Kiran	Revised	In Section 1 note 1.5 has been modified for Emergency release of Patient
5	04/May/2009	Kiran	Revised	In Section 2.8 Caster Height Adjustment Dimension Modified
6	08/Apr/2014	M.Prasad	Revised	In Section 8 "Check Doc Pedal Spring" removed
7	25/Apr/2020	J. Ward	Revised	In "Planned Maintenance Log," optimized PM and added items 10, 11, and 12, which were missing

**TABLE OF CONTENTS**

<b>1. CHECK EMERGENCY RELEASE OF CRADLE AND PATIENT TRANSPORT .....</b>	<b>5</b>
<b>2. CHECK PATIENT TRANSPORT DOCKING AND ALIGNMENT.....</b>	<b>6</b>
<b>3. CHECK PATIENT TRANSPORT CASTERS AND ARMBORARD SET SCREWS .....</b>	<b>20</b>
<b>4. CHECK PATIENT TRANSPORT CASTER LOCKS .....</b>	<b>21</b>
<b>5. CHECK CRADLE LONGITUDINAL DRIVE CLUTCH .....</b>	<b>23</b>
<b>6. CHECK PATIENT TRANSPORT FOR HYDRAULIC FILTER.....</b>	<b>25</b>
<b>7. CLEAN LIGHTWEIGHT CRADLE WHEELS.....</b>	<b>25</b>
<b>8. DOWN RELEASE CABLE SLACKNESS CHECK .....</b>	<b>27</b>
<b>9. VISUAL CHECKS .....</b>	<b>27</b>
<b>10. CRADLE HOME/TABLE DOWN INTERLOCK ADJUSTMENT .....</b>	<b>28</b>
<b>11. CRADLE RELEASE PIN HEIGHT ADJUSTMENT .....</b>	<b>29</b>
<b>12. CRADLE SIDE LOCK ADJUSTMENT .....</b>	<b>30</b>

Rev: 7 (14 May 2020)

Doc No.2387327

## 1. CHECK EMERGENCY RELEASE OF CRADLE AND PATIENT TRANSPORT

- 1.1. Dock patient transport and engage carriage assembly with cradle.
- 1.2. Drive cradle into bore approximately 24 inches (61 cm).
- 1.3. Step on the undock pedal. If the table undocks, **repair immediately** Refer to Signalite patient transport installation manual section 9, in service CD ROM Direction# 2377125.
- 1.4. Step on the table down pedal (when cradle is not on table). If the table lowers, **repair immediately** Refer to Signalite patient transport installation manual section 9. In service CD ROM Direction #2377125
- 1.5. Twist the Blue emergency release handle on end of cradle to release cradle from carriage assembly. If cradle fails to release, **Repair cradle immediately.**

Refer to Signalite patient transport service methods manual Section 23. In service CD ROM Direction#2377126.

- 1.6. Pull hard on emergency release lever, to release table from dock, See Illustration 1. If table fails to release from dock, **repair immediately** Refer to Signalite patient transport installation manual section 11. In service CD ROM Direction#2377125.

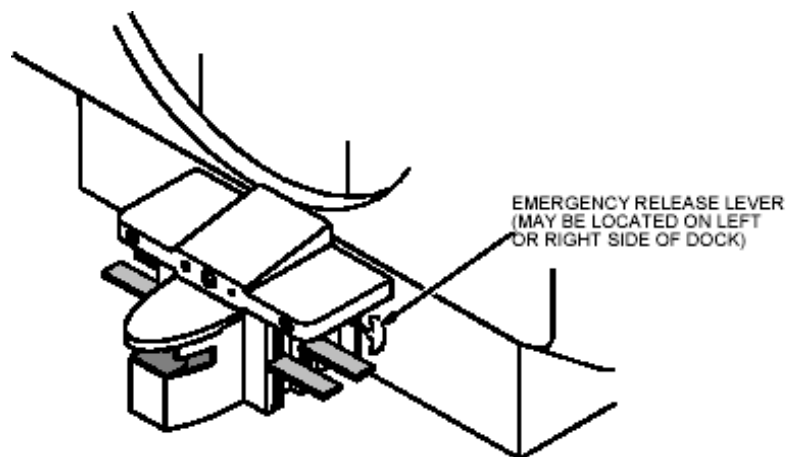

M3850A

**LOCATION OF EMERGENCY RELEASE LEVER****ILLUSTRATION 1**

Rev: 7 (14 May 2020)

Doc No.2387327

**2. CHECK PATIENT TRANSPORT DOCKING AND ALIGNMENT**

2.1. Dock patient transport by pressing DOCK pedal. Docking should not require excessive force. If excessive force is needed, hook tension is too tight. If the force is very less then hook tension is less. Do Step 2.2 to adjust hook tension. Otherwise, go to Step 4.

**CAUTION!**



**Do not adjust dock hook tension more than one turn at a time. Adjusting more than one turn at a time may cause damage to internal patient transport mechanisms.**

2.2. To Adjust dock hook tension, do the following:

To reduce hook tension follow 2.2.1, to increase hook tension follow 2.2.5

2.2.1. Loosen setscrew and lock nut near base of dock hook. See Illustration 2.

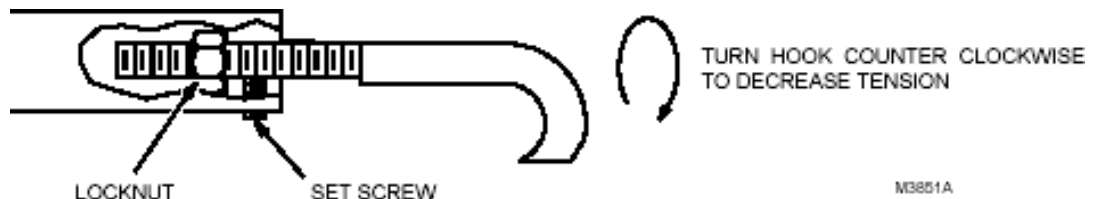

**LOCATION OF SET SCREW AND LOCK NUT**

**ILLUSTRATION 2**

- 2.2.2. Rotate hook one turn counterclockwise.
- 2.2.3. Tighten setscrew and locknut.
- 2.2.4. Repeat Step 2.1 to recheck hook tension.
- 2.2.5. Loosen setscrew and lock nut near base of dock hook, See Illustration 2.
- 2.2.6. Rotate hook one turn clockwise,
- 2.2.7. Tighten setscrew and locknut.
- 2.2.8. Repeat Step 2.1 to recheck hook tension.

**2.2.9.** If this adjustment causes transport-docking problems, restore docking hook to original position and adjust dock pedal stroke tension inside transport per Step 2.3 Below.

**2.3. Dock Pedal Stroke Adjustment.**

If adjusting dock hook tension does not relieve excessive force from the docking pedal, or caused other docking problems; adjust the dock pedal stroke. The table dock hook operates on the over-center principle. This is implemented by fixing one end of the hook to a cam on a shaft. When the force on the hook at its point of attachment to the cam is on the opposite side of the shaft as the hook end, this force will tend to keep the hook in the docked position. When the point of force is moved over-center of the shaft centerline, the force will no longer act to keep the hook retracted, and the spring-loaded cam will extend the hook to the undocked position. See Illustration 3.

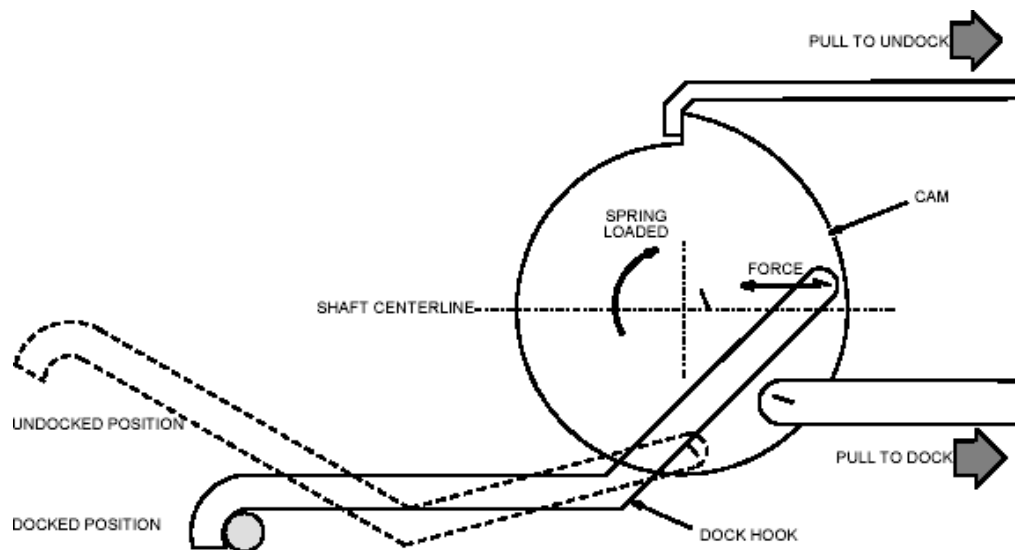

**DOCKING MECHANISM THEORETICAL REPRESENTATION**

**ILLUSTRATION 3**

**Procedure**

**2.3.1.** Move the bellows to service position, (refer to section3) of Service methods manual.

Rev: 7 (14 May 2020)

Doc No.2387327

- 2.3.2.** Tighten or loosen the stroke adjustment screw as required, such that when the dock pedal is fully depressed during the docking operation, the hook cam mechanism just goes over-center. See Illustration 4.

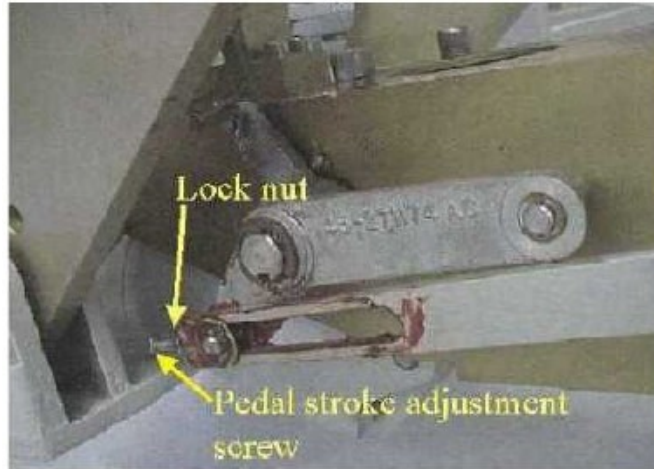

**DOCK PEDAL STROKE ADJUSTMENT**

**ILLUSTRATION 4**

- 2.4.** Press table UP pedal. Table should rise to full up position. Continue to press UP pedal a few strokes. Table should not vibrate back and forth excessively. If vibration is excessive, hook tension is too loose. Do Step 2.5 to tighten hook tension. Otherwise, go to Step 2.6.
- 2.5.** To tighten dock hook tension, do the following:
- 2.5.1.** Loosen setscrew and lock nut near base of dock hook. See illustration 2.
  - 2.5.2.** Rotate hook one turn clockwise.
  - 2.5.3.** Tighten setscrew and lock nut.
  - 2.5.4.** Repeat Step 4 to recheck hook tension.
  - 2.5.5.** If this adjustment causes transport-docking problems, restore docking hook to original position and adjust dock pedal stroke tension inside transport per Illustrations 3 and 4.
- 2.6.** Drive cradle into bore approximately 24 inches (61 cm). Release cradle from carriage by squeezing or twisting the emergency release handle at end of cradle. Remove cradle from tabletop.

Rev: 7 (14 May 2020)

Doc No.2387327

- 2.7. Lay a nonferrous straight edge, across bridge and tabletop to check if tabletop is in level to bridge in both directions. See Illustration 6. If table is not in level with bridge, casters must be adjusted. Note how much adjustment is required and go to Step 2.9. Otherwise go to Step 2.8.

**WARNING!**

**ENSURE DISTANCE BETWEEN BOTTOM EDGE OF CASTER BUSHING AND BASE OF TAPERED SHAFT IS NOT MORE THAN ¼. (6.4 mm). ANY LARGER DISTANCE WILL LEAVE CASTER BUSHING VULNERABLE TO DAMAGE, WHICH CAN RESULT IN INJURY TO PATIENT AND/OR PERSONS NEAR PATIENT TRANSPORT.**



- 2.8. Check height of table casters. Distance between top of aluminum support casting and floor should be 11.0 ± 1/4 inches (279 ± 6.4mm). See Illustration 5. If any casters are out of tolerance, note how much Adjustment is required and go to Step 2.9. Otherwise, go to Step 2.13.

**CAUTION!!!**

**Make certain that the height measurement requirement is adhered to. Not adhering to the Height measurement may cause a caster to come loose from the table.**



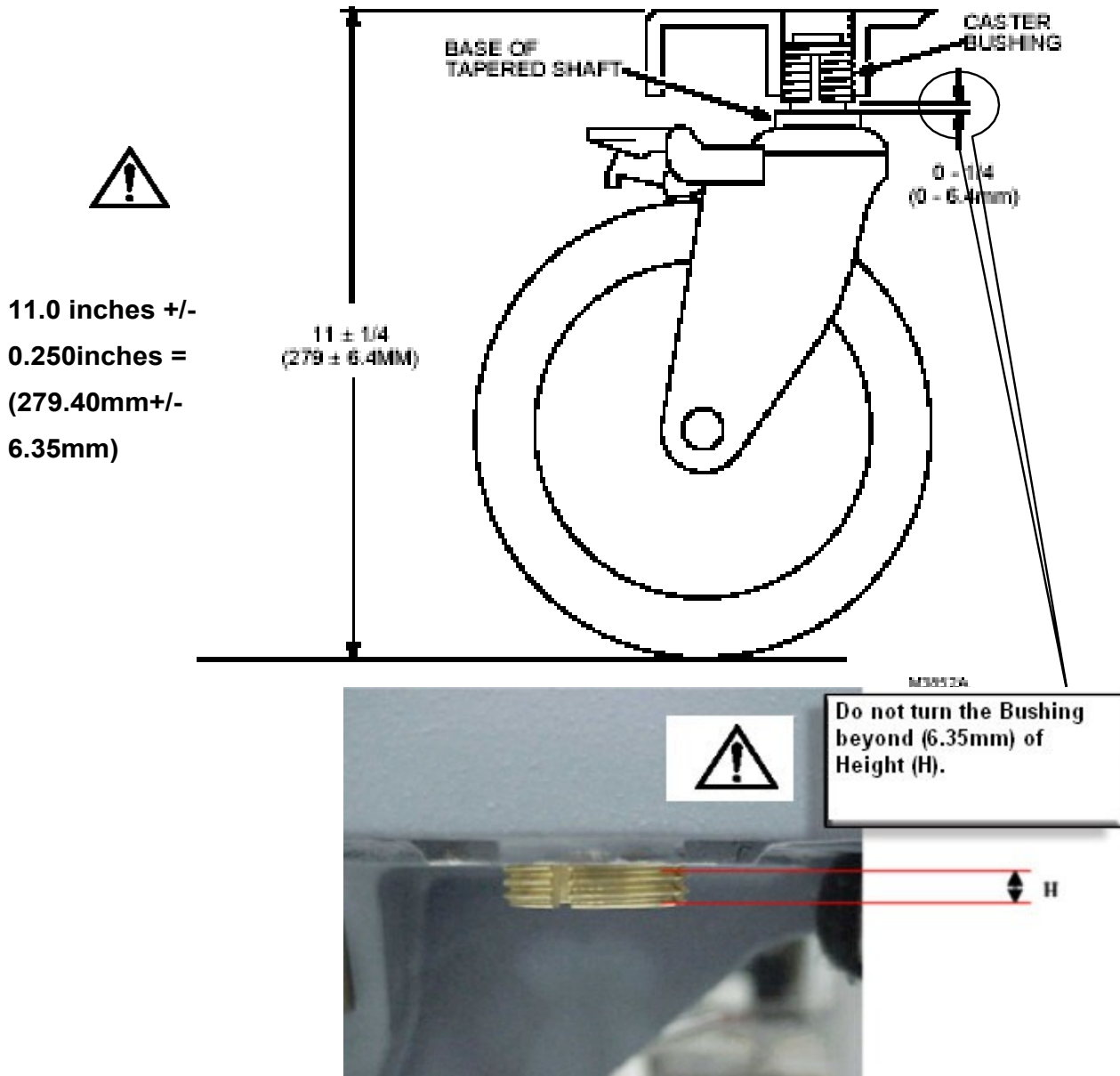

**CAUTION!!!**  
**DO NOT TURN THE BUSHING BEYOND (6.35mm) OF HEIGHT (H)**

CHECKING HEIGHT OF CASTER  
ILLUSTRATION 5



**CHECKING LEVEL OF TABLE**  
**ILLUSTRATION 6**

**DANGER!!!**



**FERROUS MATERIAL HAZARD!! TORQUE WRENCH AND SOCKET DRIVE CONTAIN FERROUS MATERIAL AND CAN BE FORCIBLY ATTRACTED TO MAGNET. DO NOT BRING WRENCH AND SOCKET DRIVE INTO MAGNET ROOM.**

2.9. Undock patient transport and move it out of magnetroom.

**WARNING!**



**ADJUSTMENTS THAT EXCEED TOLERANCES SHOWN IN ILLUSTRATION 5 LEAVE CASTER BUSHING VULNERABLE TO DAMAGE, WHICH CAN RESULT IN INJURY TO PATIENT AND/OR PERSONS NEAR PATIENT TRANSPORT.**

2.10. To adjust a caster, do the following:

2.10.1. Remove caster mounting cap by prying it off with a small screwdriver. See Illustration 7.

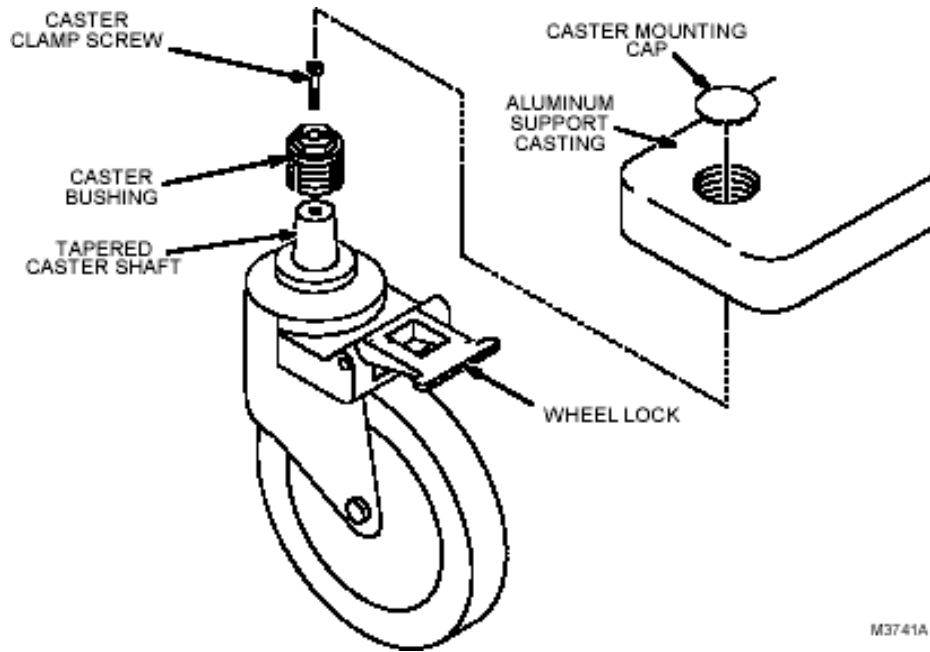

M3741A

**CASTER WHEEL ASSEMBLY**

**ILLUSTRATION 7**

- 2.10.2.** Remove castor clamp screw (cap screw) from its hole, and screw it into one of the empty castor release Screw holes, finger tight only.
- 2.10.3.** Go to another castor assembly and remove castor clamp screw. Bring borrowed castor clamp screw back to castor being adjusted.
- 2.10.4.** At castor being adjusted, screw borrowed castor clamp screw into other empty castor release screw hole, finger tight only.

Rev: 7 (14 May 2020)

Doc No.2387327

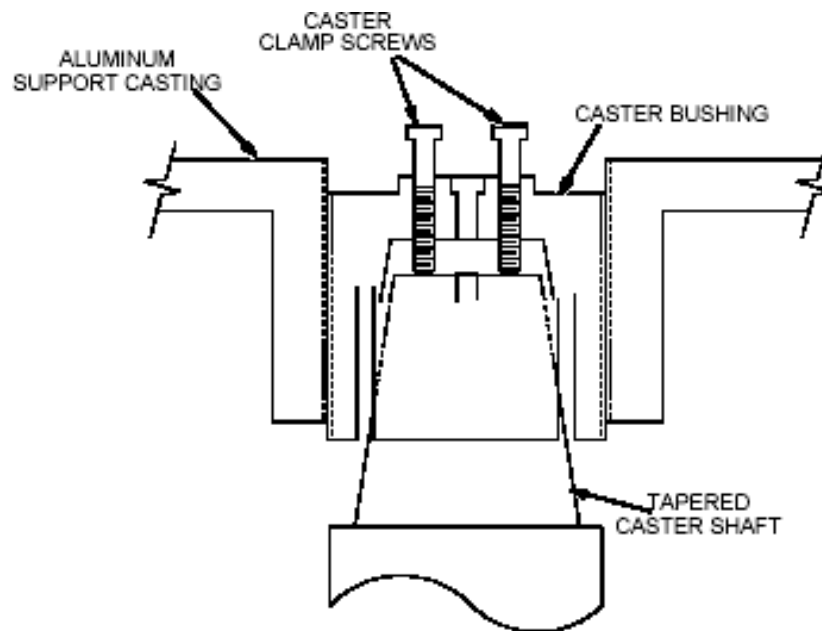
**CASTER MOUNTING CONSTRUCTION**

## ILLUSTRATION 8

- 2.10.5. Alternately screw in caster clamp screws one turn at a time until tapered caster shaft is as loose as possible in caster bushing. See Illustration 8.
- 2.10.6. Using a means of leverage, slightly prop up aluminum support casting (at caster being adjusted) only enough to take patient transport weight off caster wheel. This will disengage caster shaft from caster bushing and prevent excessive wear on threads during adjustment.
- 2.10.7. Remove both caster clamp screws from caster release screw holes.
- 2.10.8. Activate wheel lock at caster being adjusted. See Illustration 7.

**WARNING!**

**ADJUSTMENTS THAT EXCEED TOLERANCES SHOWN IN ILLUSTRATION 5 LEAVE CASTER BUSHING VULNERABLE TO DAMAGE, WHICH CAN RESULT IN INJURY TO PATIENT AND/OR PERSONS NEAR PATIENT TRANSPORT.**



Rev: 7 (14 May 2020)

Doc No.2387327

**Note:**

It may not be possible to maintain tolerances shown in Illustration 5 and keep patient transport level with bridge. Try to do the best job possible while maintaining tolerances.

- 2.10.9.** While holding caster wheel, use a 19 mm socket to turn caster bushing counterclockwise to raise table corner or clockwise to lower table corner. Each complete revolution of caster bushing raises or lowers caster 0.083 (approximately 3/32) inch (2.1 mm).
- 2.10.10.** Remove prop from under aluminum support casting.
- 2.10.11.** Return borrowed caster clamp screw to its original caster assembly.
- 2.10.12.** At caster being adjusted, insert remaining caster clamp screw into caster clamp screw hole.
- 2.10.13.** Using torque wrench (46-194427P255) and socket driver (46-307811P1), torque caster clamp screw to 50 inch. Pounds (56 Nm). If necessary, refer to operating instructions supplied with the torque wrench.
- 2.10.14.** Verify that caster shaft is seated well into caster bushing and that gap between bottom of caster bushing and base of caster shaft is less than 1/4 inches (6.4 mm).
- 2.10.15.** Reinstall caster mounting cap.
- 2.10.16.** Repeat Steps 2.10.1 through 2.10.16 for each caster to be adjusted.
- 2.11.** Move patient transport back into magnet room, and dock transport to magnet.
- 2.12.** Repeat Steps 6 and 7 to recheck height of all casters. When all casters are properly adjusted, continue with Step 2.13.
- 2.13.** Lay a nonferrous straight edge across bridge and tabletop to check height of tabletop compared to height of bridge. Tabletop should be equal to bridge height so cradle will stay latched as it drives into

bore. If adjustment is needed, move the bellows to service position (refer to Section-2.1 of installation manual) and set the table height (follow Section- 6.2 of installation manual) illustration 9

**2.14.** Lay nonferrous straight edge along guide ridge, on bridge and tabletop. Table and bridge should be aligned both right.to.left and in a straight line.See Illustration 10. If alignment is needed, go to Step **2.15.** Otherwise, go to Step 2.16.

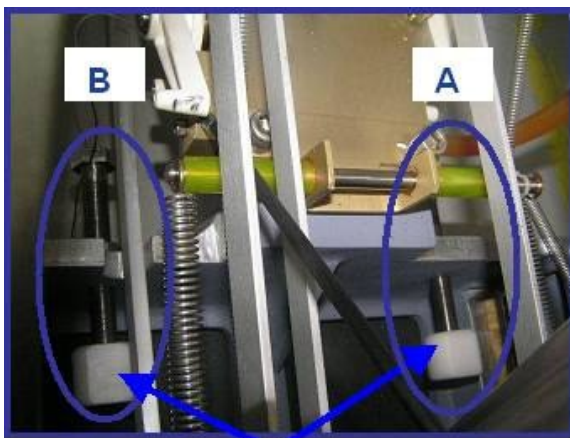
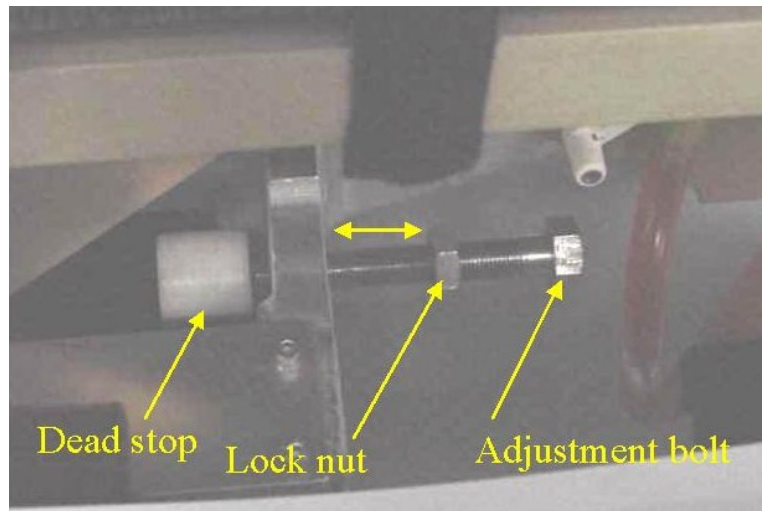

DEAD STOPPER ASSEMBLY

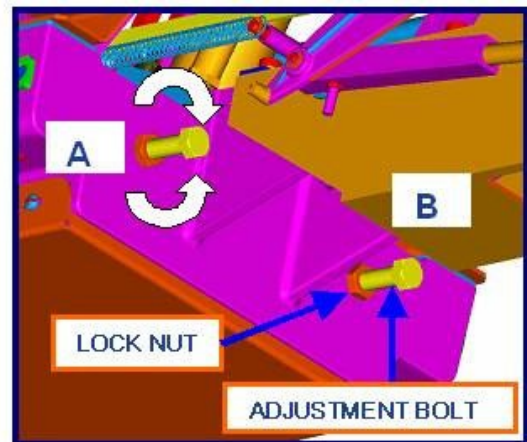

ADJUSTING TABLE HEIGHT.

ILLUSTRATION 9

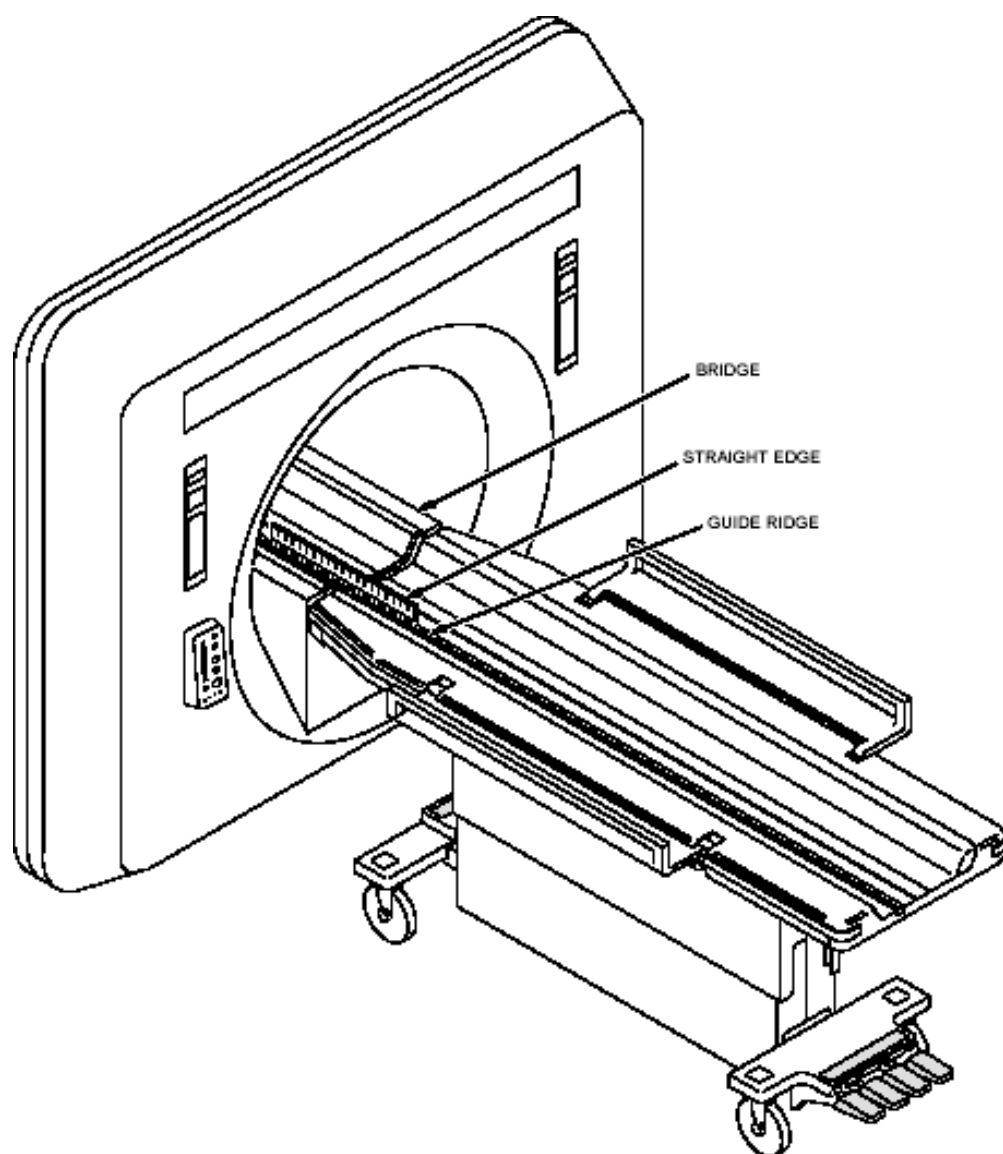

M3062A

**ALIGNING TABLE TO BRIDGE**

**ILLUSTRATION 10**

**2.15.** There are two types of adjustment: right -to- left and straight line.

**2.15.1.** If right-to-left adjustment is needed, loosen four dock-mounting bolts. See Illustration 11. Move dock right or left as needed, and then retighten bolts.

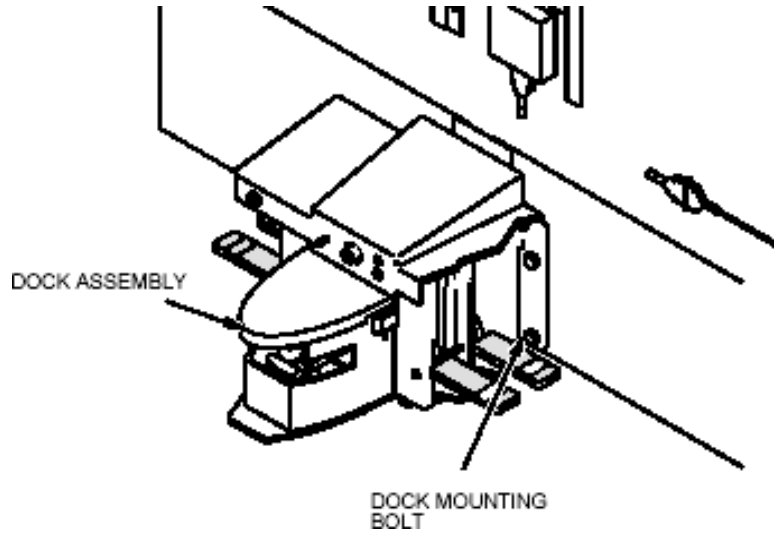

**DOCK MOUNTING BOLT**

**ILLUSTRATION 11**

**2.15.2.** If straight-line adjustment is needed, loosen bolts on left or right dock support. See Illustration 12 and 12A. Adjust the angle of the dock assembly with respect to the bridge as needed, and then retighten bolts.

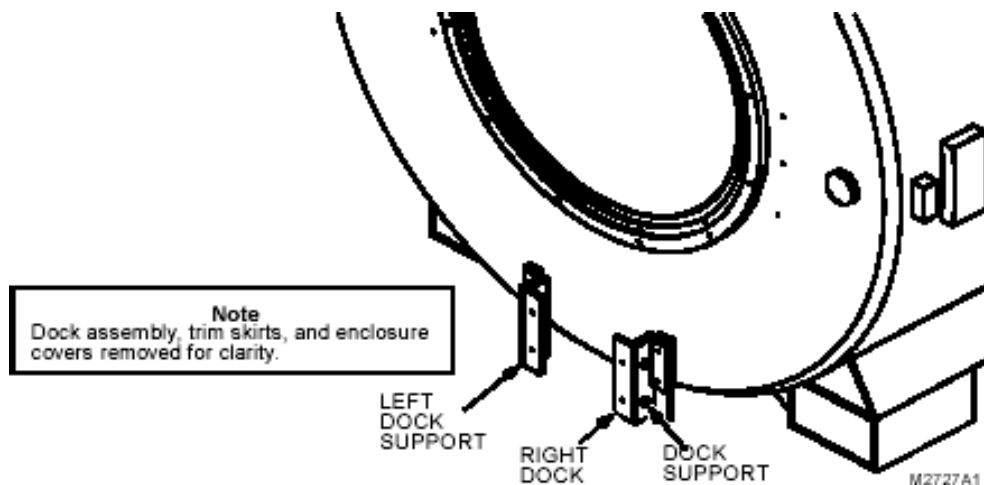

**DOCK SUPPORT BOLTS  
ILLUSTRATION 12**

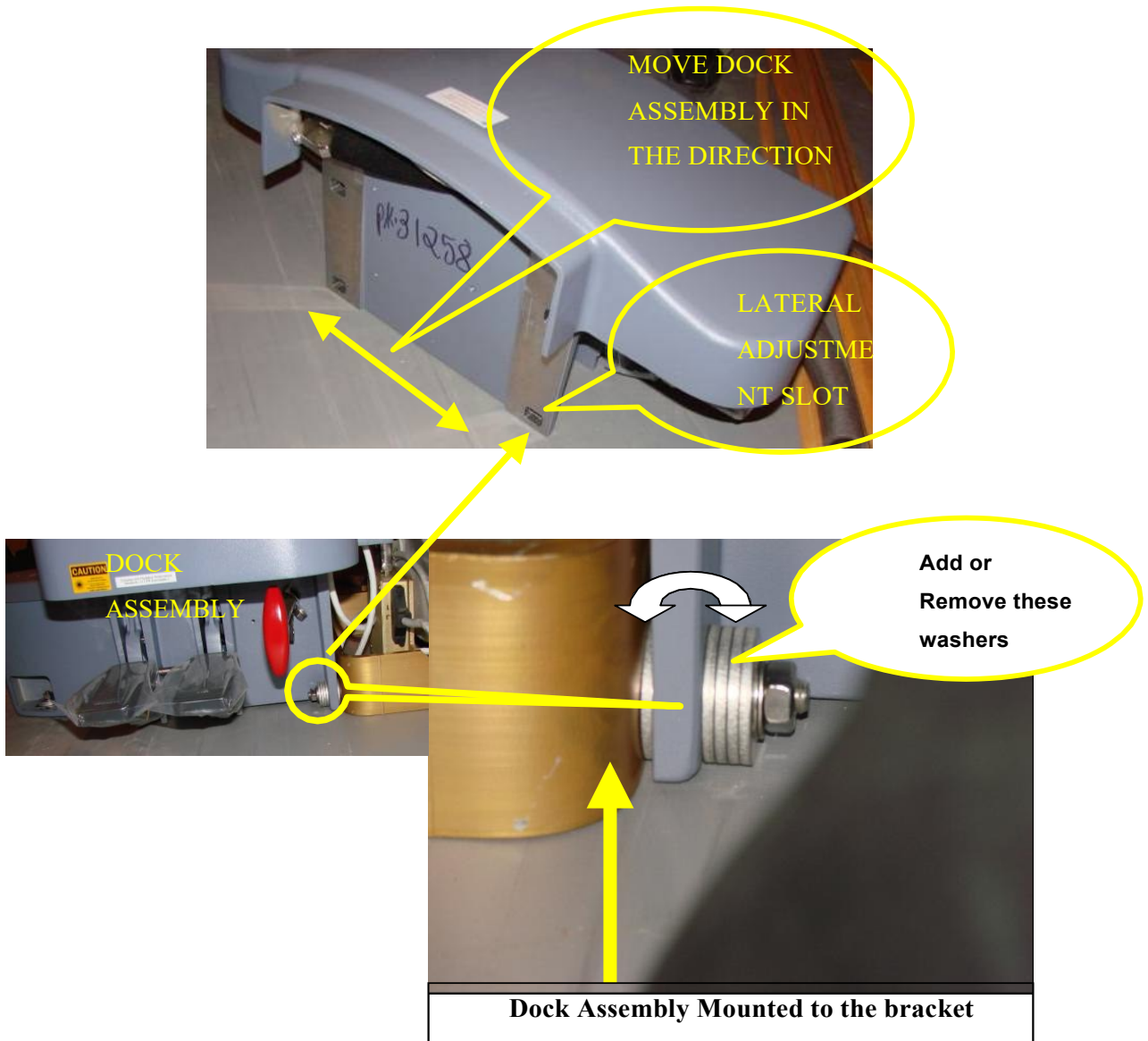

**ILLUSTRATION 12 A**

Rev: 7 (14 May 2020)

Doc No.2387327

- 2.16.** Check for a gap 1-inch  $\pm$  1/4 inch (25.4  $\pm$  6.4 mm) between table and bridge. If gap is not correct, loosen bolts on left and right dock supports. See Illustration 12 and 12A. Move dock towards or away from magnet, Use Washers to set the gap between the table and the front bridge, i.e move the dock assembly front or back to set Dimension, making sure table is still in a straight line with bridge, until gap is correct. Then, tighten left and right dock support bolts.
- 2.17.** Press table DOWN pedal. Verify carriage drives back into bore a few inches. If carriage does not drive back, schedule time to repair table up limit switch.
- 2.18.** Press table UP pedal until table is fully up. Verify carriage drives out of bore until it connects with cradle latch.
- 2.19.** Inspect underside of cradle. Verify all eight bearings and their retaining screws are present and intact.  
Replace any missing or damaged parts:  
Bearing: 46.243178P3
- 2.20.** Place cradle back on table and bridge.
- 2.21.** Drive carriage fully into bore.
- 2.22.** With cradle unlatched, verify cradle rolls smoothly in and out of bore.
- 2.23.** Drive carriage out and verify it latches with cradle.
- 2.24.** Drive carriage in and out with cradle latched. Verify cradle stays latched to Carriage.

Rev: 7 (14 May 2020)

Doc No.2387327

## 12. CRADLE SIDE LOCK ADJUSTMENT

12.1 Remove Cradle Assembly from Patient table as per procedure in [Section 1 of installation manual](#).

12.2 Check if the Cradle side lock is functioning ( ie locking / unlocking properly ).If any malfunction refer to section 16 of installation manual for setting the cradle side lock. See Illustration 13.

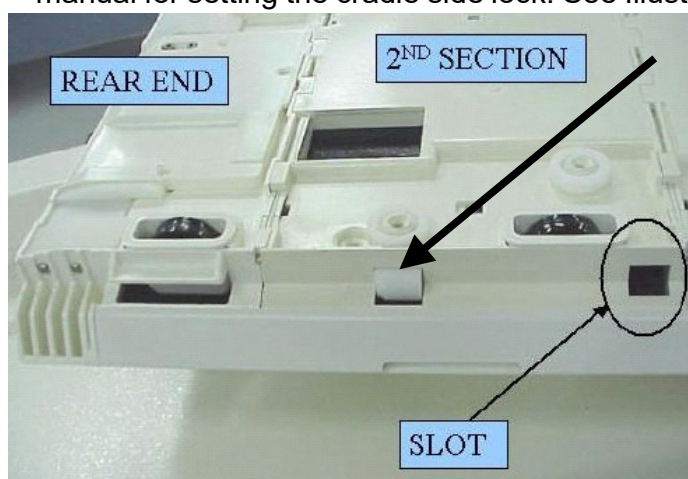
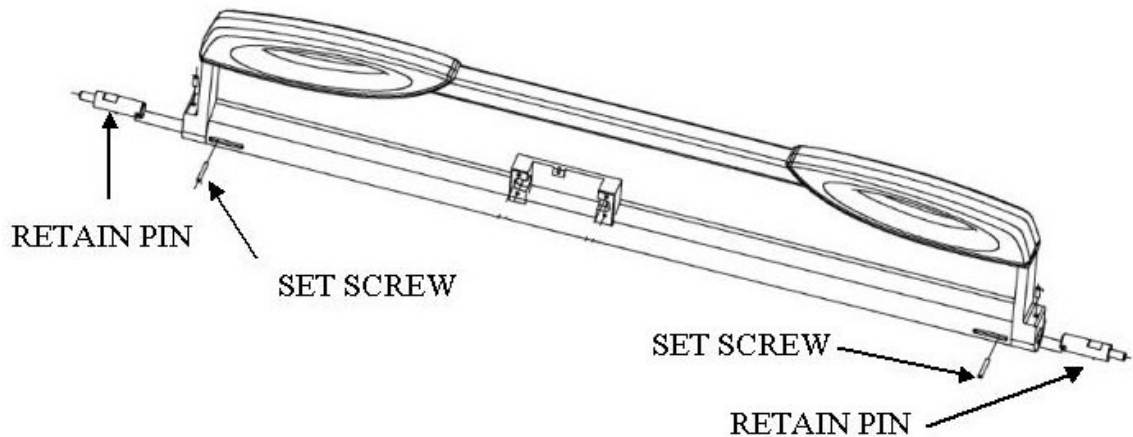

ILLUSTRATION 13



#### ARMBOARD SET SCREWS

#### ILLUSTRATION 14

### 4. CHECK PATIENT TRANSPORT CASTER LOCKS

#### Note

The right front caster lock is used to lock caster rotation (steering) only, not to lock wheel rotation.

**11.1.** Press down on one of the three caster wheel locks (one on left front left caster and one on each of the two ear casters). See Illustration 15. Verify that caster wheel does not rotate when lock is engaged, then release caster lock. Verify caster wheel rotates freely when lock is not engaged.

**11.2.** Repeat Step 1 for other two caster wheel locks.

**11.3.** If any caster lock does not work properly, repair or replace it **IMMEDIATELY.**

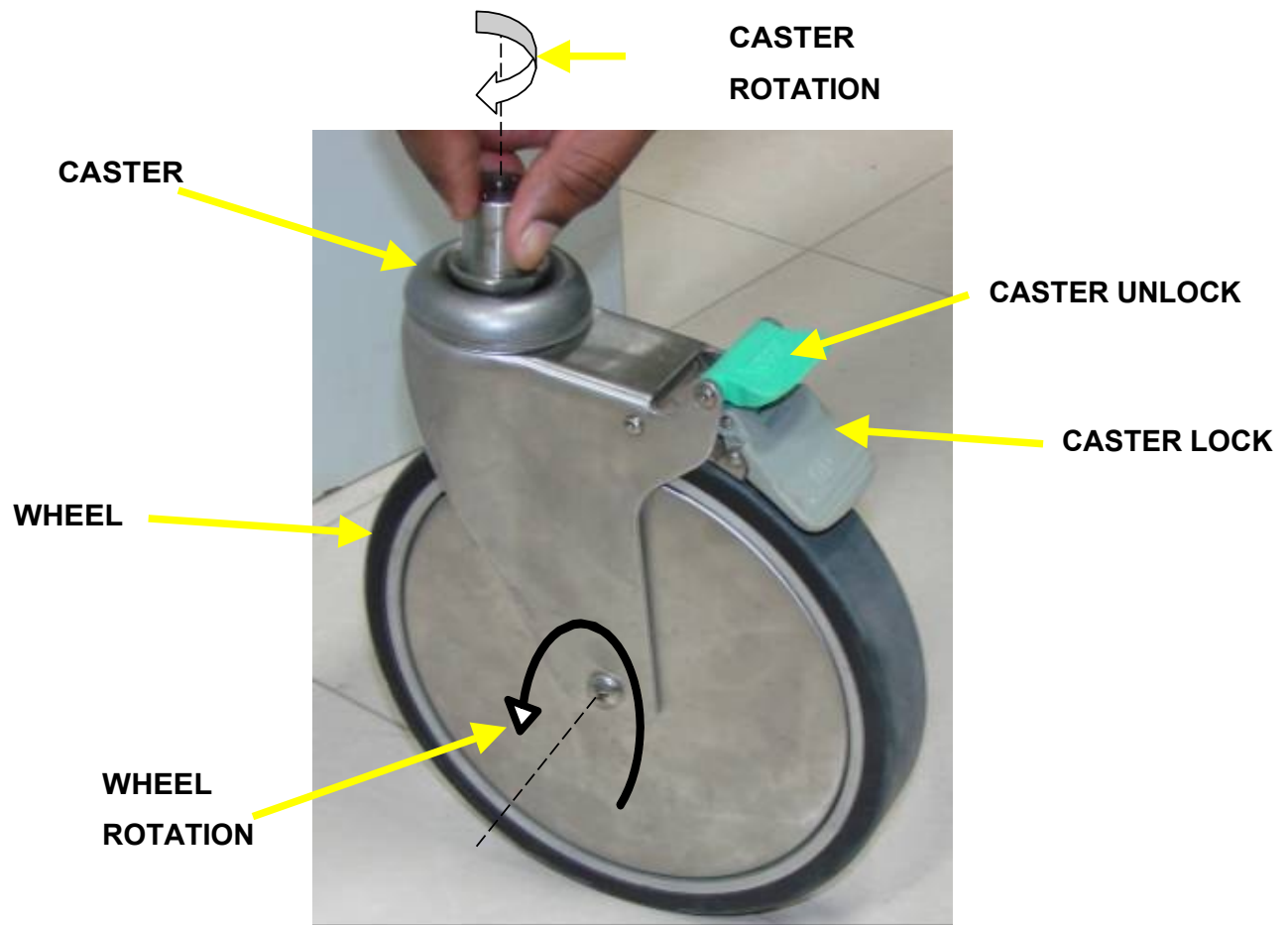

**LIGHTWEIGHT PATIENT TRANSPORT CASTERLOCKS  
ILLUSTRATION 15**

Rev: 7 (14 May 2020)

Doc No.2387327

**5. CHECK CRADLE LONGITUDINAL DRIVE CLUTCH**

11.4. Position head coil carriage to the magnet opening at the rear.

11.5. Position Longitudinal Drive Force Gauge (46-307500P1) at rear of bridge with rod end of gauge facing magnet rear. See Illustration 16. Make sure rod is pushed into gauge as far as it will go.

11.6. Fast-forward carriage into magnet bore, making contact with “L” shaped piece on gauge, and forcing rod to protrude from gauge.

11.7. When clutch is properly tensioned, rod should only protrude far enough to show area between inked calibration lines on rod. If first line is not visible, or if more rod is visible past second line, clutch tension requires adjustment. See Illustration 17.

Remove Rear Pedestal covers to gain access for clutch adjustments.

11.8. Repeat Steps 5.3 and 5.4 until clutch is properly tensioned.

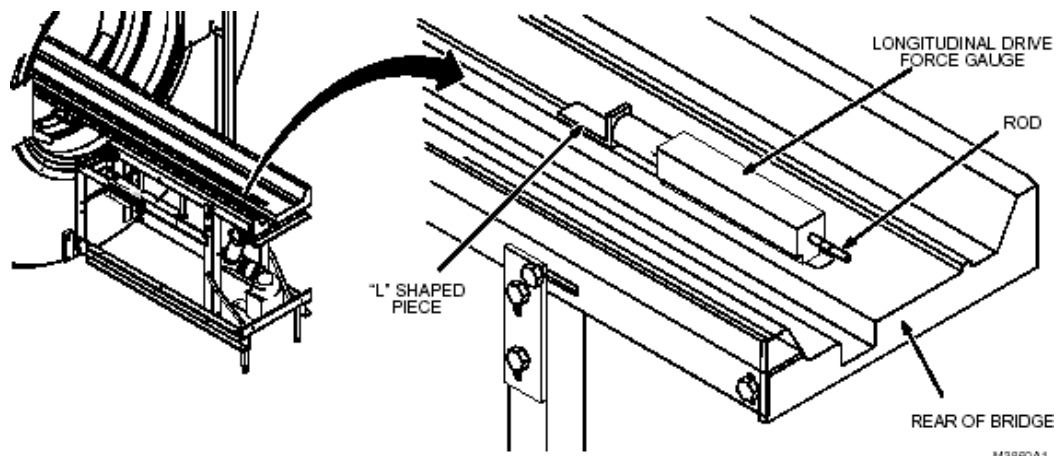

**LONGITUDINAL DRIVE FORCE GAUGE**

**ILLUSTRATION 16**

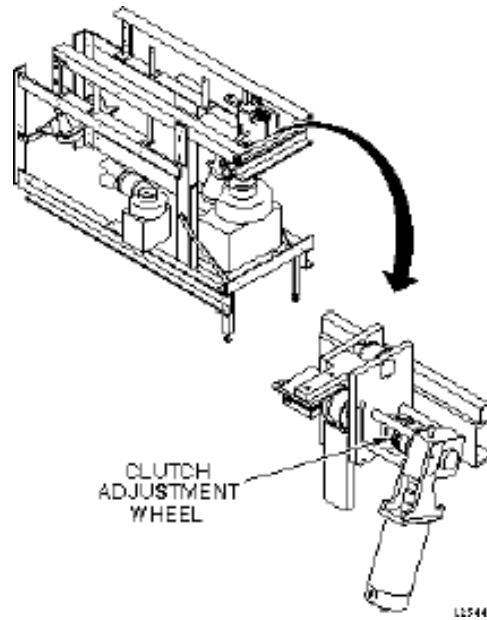

**CLUTCH ADJUSTMENT FOR LONGITUDINAL DRIVE WITHOUT PULLEYS  
ILLUSTRATION 17**

Rev: 7 (14 May 2020)

Doc No.2387327

**6. CHECK PATIENT TRANSPORT FOR HYDRAULIC FILTER**

- 11.9. With the Patient Transport docked, lower it to its lowest position.
- 11.10. Press Table –UP pedal on dock and verify table travels from lowest to highest position in 20 seconds or less with table unloaded.
- 11.11. Press Table–Down Pedal on dock and verify table travels from highest to lowest position in 24 seconds or less with table unloaded.
- 11.12. If either of these functional checks fails, schedule time to change the table filter element.

**7. CLEAN LIGHTWEIGHT CRADLE WHEELS**

- 11.13. Remove table cradle and turn over on its back.
- 11.14. Using a flathead screwdriver, lift out each cradle wheel. See Illustration 18.

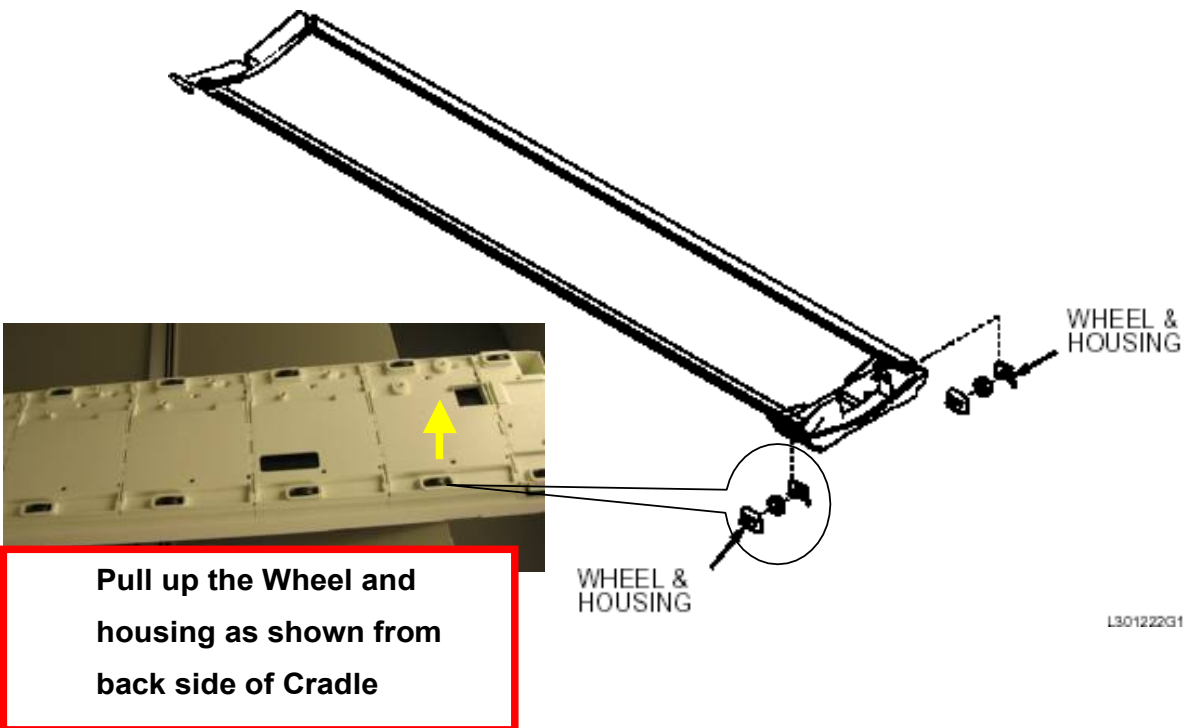

**CRADLE WHEELS  
 ILLUSTRATION 18**

**Rev: 7 (14 May 2020)**

**Doc No.2387327**

**11.15.** Open wheels, follow ILLUSTRATION 18A for disassembly of wheels

**11.16.** Check for any damages, wear and tear of wheels

**11.17.** Change and replace the wheels if the wheels are damaged.

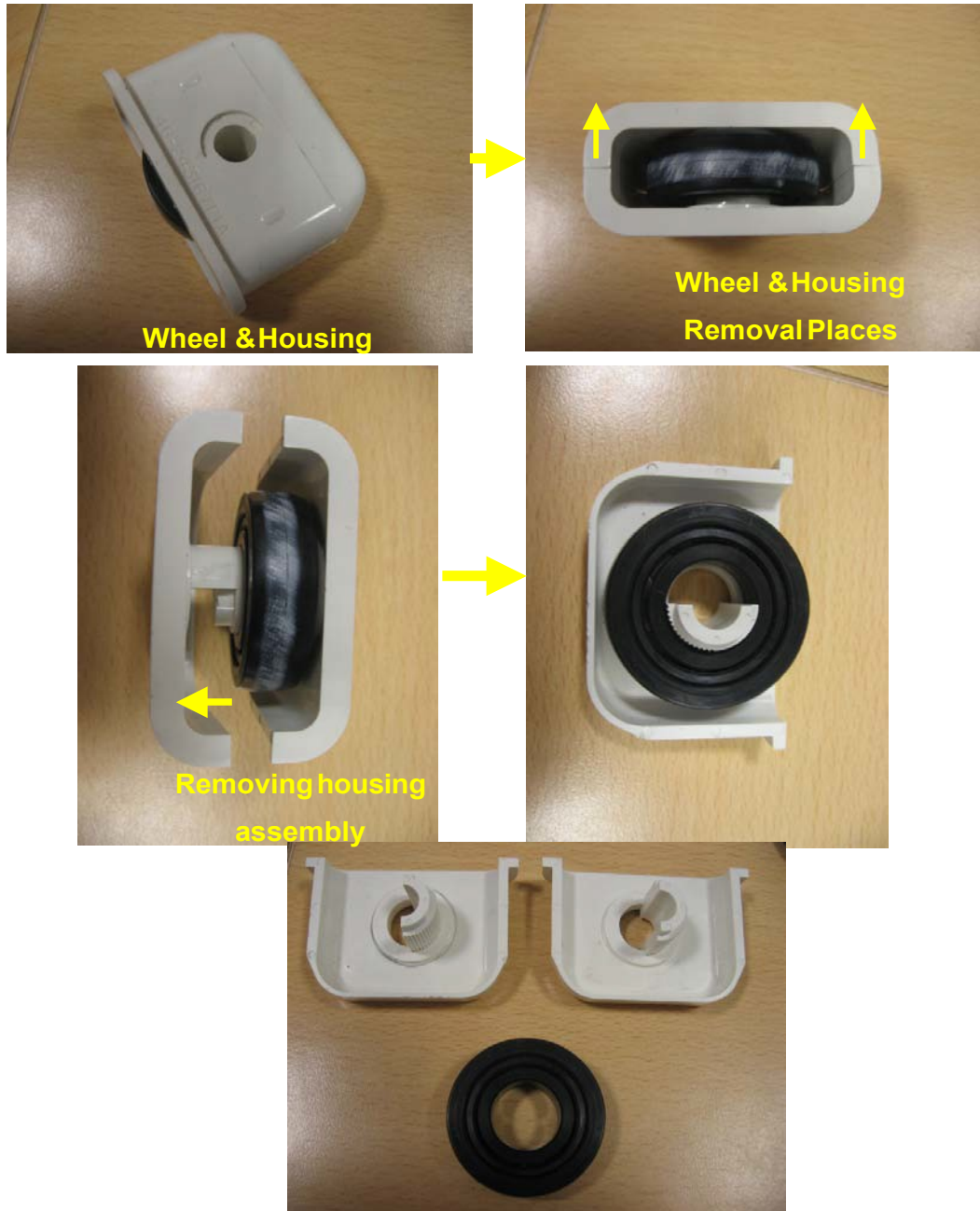

**ILLUSTRATION 18 A**

Rev: 7 (14 May 2020)

Doc No.2387327

## 8. DOWN RELEASE CABLE SLACKNESS CHECK.

**11.18.** Undock the table and move away from the magnet now, pump the table to full height and bring it down using the down pedal note the time it takes to come down, if the time taken for the table to move down is more than the specified time of 24 sec then the cable slackness has to be adjusted.

**11.19.** Follow procedure from Section 14 &15 in Installation manual.

## 9. VISUAL CHECKS

### 11.20. SPRING BOOSTERS.

Lift the spring booster cap if it comes off, then replace the spring booster assembly, Refer to Section 20 of service methods manual.

### 11.21. CHECK THE RESERVOIR OIL LEVEL

The level should be between the specified marks when the table is in top most condition if the oil level is below the specified mark then fill upto marked line refer illustration 19 below. Follow instructions from installation manual Section 12.



**ILLUSTRATION 19**

Rev: 7 (14 May 2020)

Doc No.2387327

**11.22. PEDAL BUMPERS.**

Check the rubber pedal bumpers, if any damage or if broken, replace. Refer to illustration 20

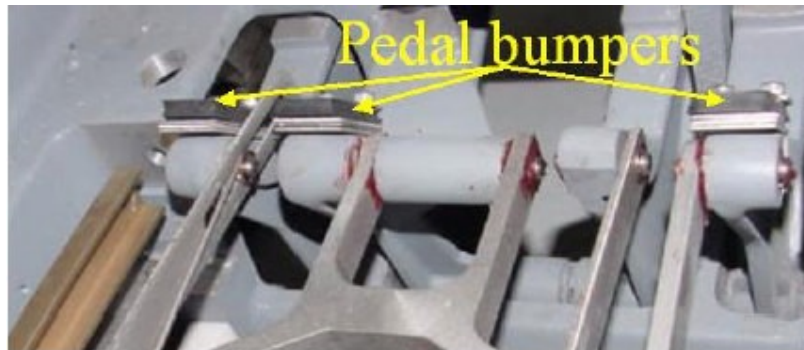
**ILLUSTRATION 20****10. CRADLE HOME/TABLE DOWN INTERLOCK ADJUSTMENT**

**11.23.** This adjustment is for the mechanical interlock, which prevents the Patient transport from being undocked or lowered while the cradle is in the magnet bore.

**11.24.** Undock table and move away from magnet, Move bellows to service position and fasten using Velcro straps.

**11.25.** Remove the cradle (Refer to [Section 1 of installation manual](#)), with cradle NOT HOME (removed), check the interlock mechanisms for tolerances shown in Illustration 21, if out of tolerance refer to installation manual section 9 to set.

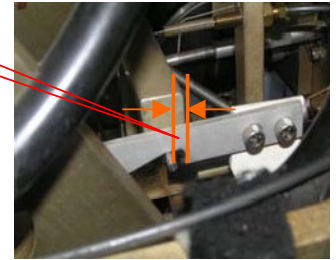
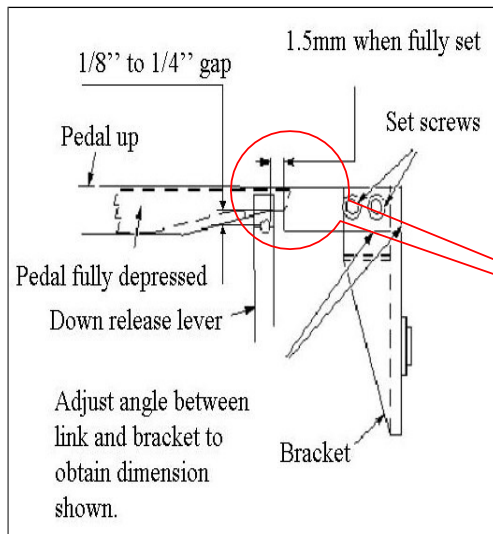

ILLUSTRATION 21

**11. CRADLE RELEASE PIN HEIGHT ADJUSTMENT**

11.1. Remove Cradle Assembly from Patient table as per procedure in [Section 1 of installation manual](#).

11.2. The cradle release pin should be 1/8 inch (3 mm) below the level of the tabletop. See Illustration 22, if it is above the specified value refer to [Section 10](#) of installation manual for setting procedure.

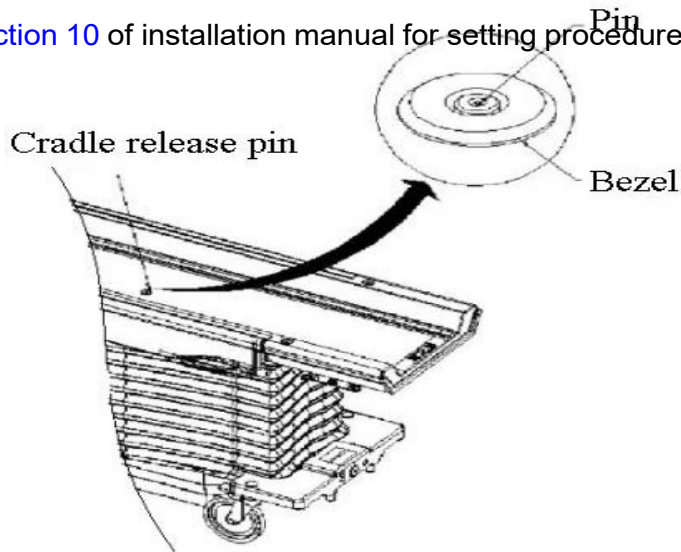

ILLUSTRATION 22

Rev: 7 (14 May 2020)

Doc No.2387327

## 12. CRADLE SIDE LOCK ADJUSTMENT

12.1 Remove Cradle Assembly from Patient table as per procedure in [Section 1 of installation manual](#).

12.2 Check if the Cradle side lock is functioning ( ie locking / unlocking properly ).If any malfunction refer to section 16 of installation manual for setting the cradle side lock. See Illustration 23.

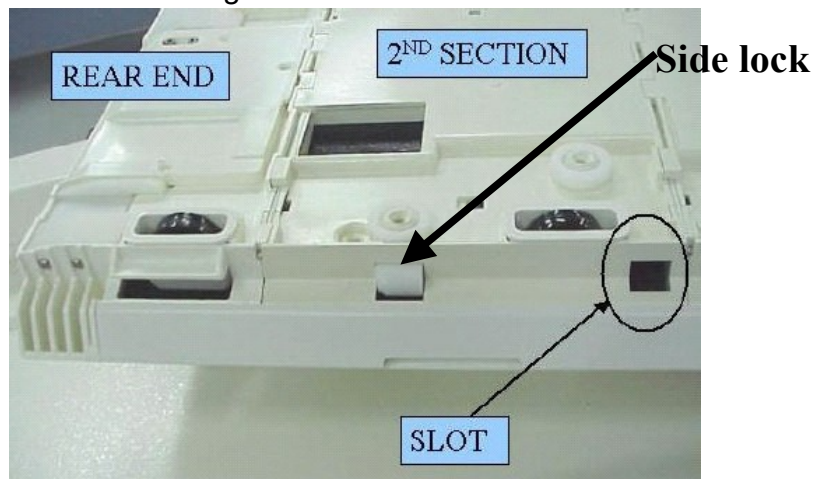

ILLUSTRATION 23