

A

B

C

D

REVISION	ECR/ECO	DATE	SIGN OFF
REV1	-----	17-JUN-09	ZOU LULU
REV2	ECO2085478	17-JUL-09	ZOU LULU

PAGE	DESCRIPTION OF CHANGE	BY
1	ADD SCHEMATIC NOTE, REVISION AND CHANGE DESCRIPTION.	ZOULULU
2	CHANGE SIGNAL NAME'S DESCRIPTION.	ZOULULU
3	CHANGE SIGNAL NAME'S DESCRIPTION, REMOVE C4,D4,C8,D8,C3,	ZOULULU
3	REMOVE D3,C7,D7,C9,D9,C10,D10,C11,D11,C12,D12,JP4,JP5,JP6.	ZOULULU
4	ADD THIS PAGE, ADD C4,D4,C8,D8,C3,D3,C7,D7,JP6.	ZOULULU
5	ADD THIS PAGE AND C9,D9,C10,D10,C11,D11,C12,D12,JP4,JP5.	ZOULULU

NOTES:

1. THE VARIATION AND VERSION FOR THIS PWA IS 6318383.
2. THIS COVER SHEET CONTROLS THE REVISION STATUS OF THE ENTIRE DOCUMENT. THE REVISION OF ALL SHEETS OF THIS DOCUMENT WILL BE AT THE SAME LEVEL.
3. THIS SCHEMATIC MEETS THE SPECIFICATIONS OF THE GLOBAL SCHEMATIC STANDARD GUIDELINES 2299773GSP.
4. ELECTRONIC SIGNATURES FOR BOTH THE SCHEMATIC REVIEWER(S) AND APPROVER(S) CAN BE FOUND WITHIN MY WORKSHOP.
5. UNLESS OTHERWISE SPECIFIED:
RESISTORS ARE IN OHMS.
CAPACITORS ARE IN FARADS.
INDUCTORS ARE IN HENRIES.
6. THE PROJECT FILE PATH IS
3.35.117.210:/HOME/MR/MRBJEE.

A

B

C

D

REV 2 09/04
B Size

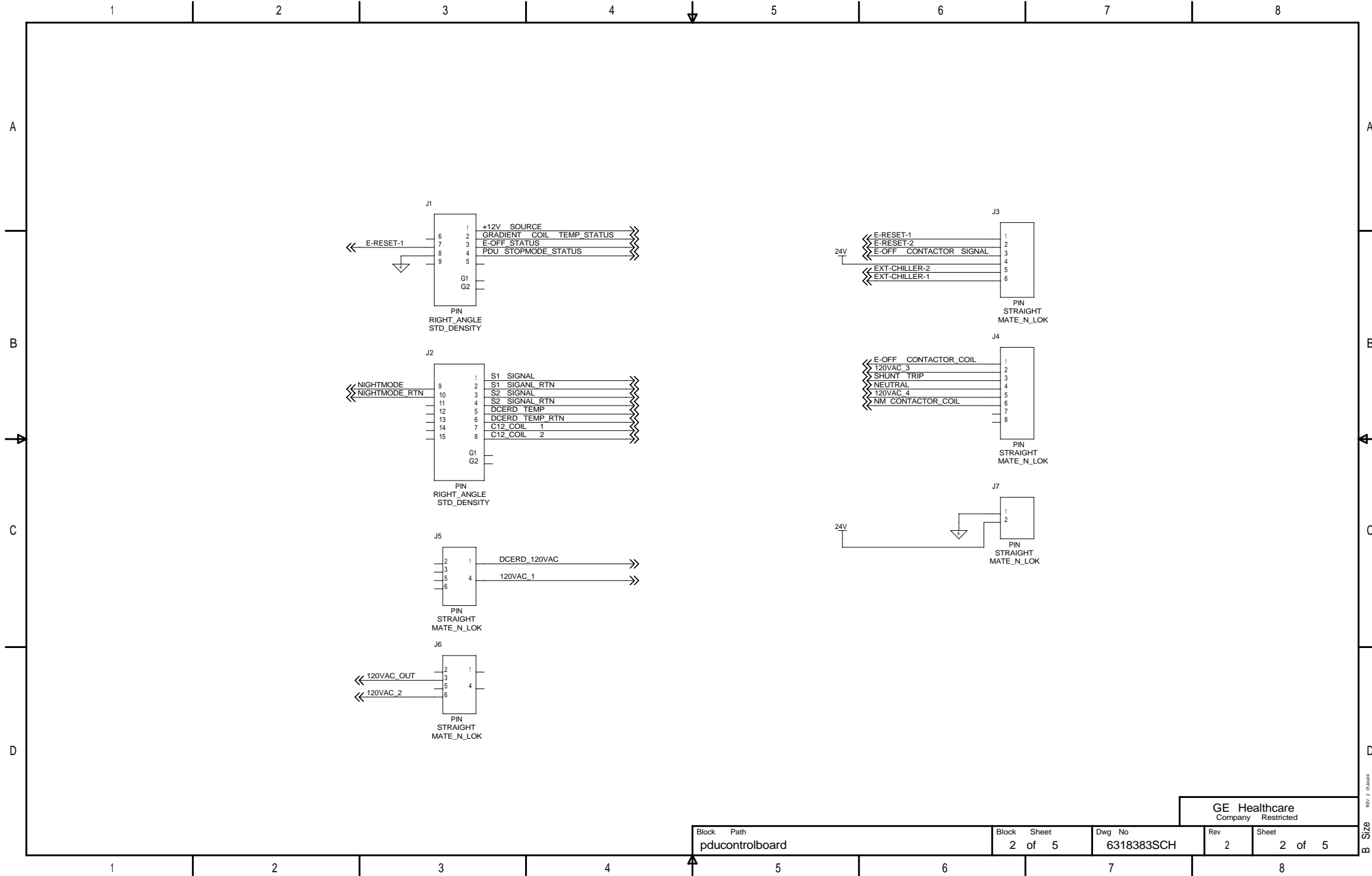

Block Path	Block Sheet	Dwg No	Rev	Sheet
pducontrolboard	2 of 5	6318383SCH	2	2 of 5

GE Healthcare
Company Restricted

1 2 3 4 5 6 7 8

A

B

C

D

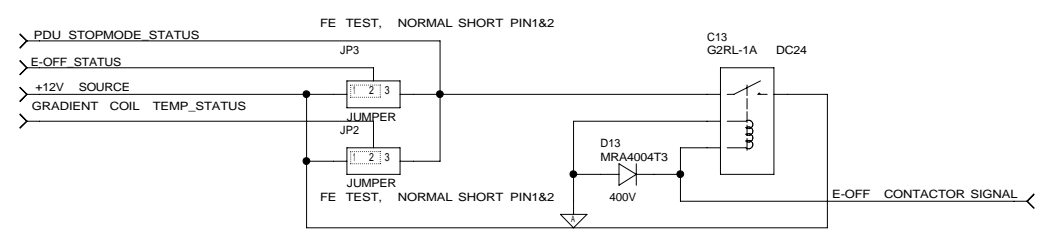
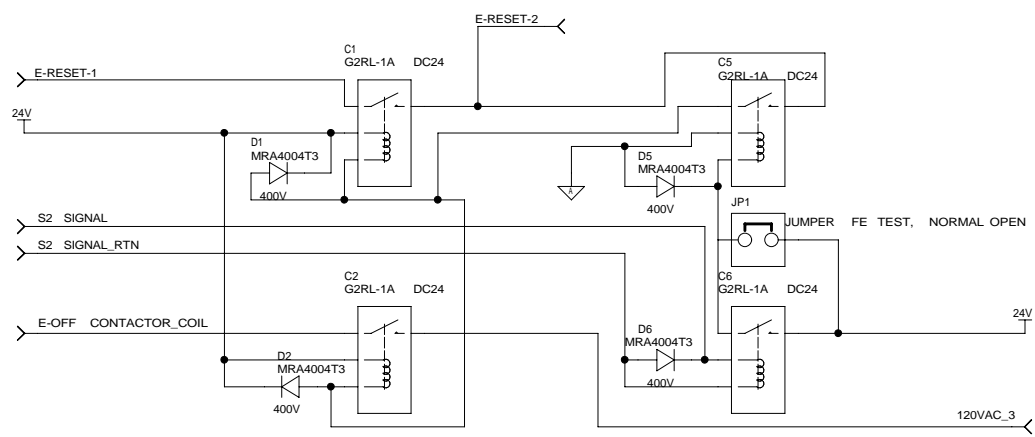

1 2 3 4 5 6 7 8

1 2 3 4 5 6 7 8

A

B

C

D

A

B

C

D

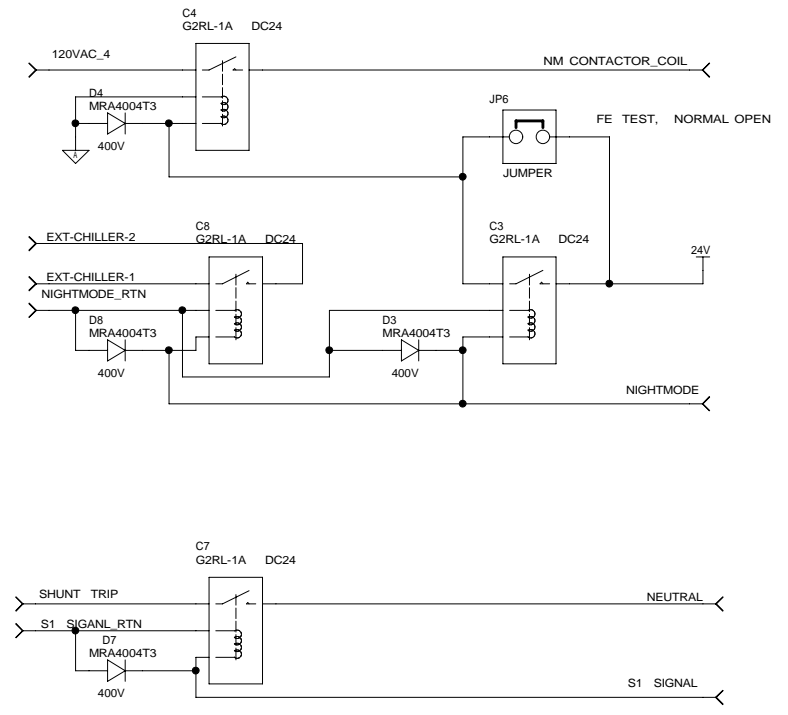

Sat Jul 18 14:07:19 2009

1 2 3 4 5 6 7 8

Block Path	Block Sheet	Dwg No	Rev	Sheet
pducontrolboard	4 of 5	6318383SCH	2	4 of 5

GE Healthcare
Company Restricted

REV 2 09/04
B Size

