

**SYSTEM INTERCONNECT**

(Without facility water & Non Equipment room-400V,  
Detachable table)

- NOTES:**
- 1 Customer furnished
  - 2 Magnet and superconducting shim power supplies are not included with system, but may remain in place if purchased as an option.
  - 3 Dotted line can be available, in the case of Common Ground is installed.
  - 4 Typical connection for normally closed emergency off switch.
  - 5 Optional: May not be present on all systems.
  - 6 Magnet ramping cables pass through rampout on PP1 plate.
  - 7 RUNS(600 SERIES) Furnished with GE Magnet.
  - 8 RUNS 823 To 833 Furnished Magnet Monitoring.
  - 9 Body Hybrid To Body Coil Connections depend on magnet field portlarity.
  - 10 Customer supplied telephone line for Insite Modem.
  - 11 Ethernet cable is customer supplied. RUN E3045 and modem may not be required if connection to Insite is provided through site ethernet connection.
  - 12 J1000 is on the Mounting Plate of the Magnet Side Kit
  - 13 This cable is for 16 channel system

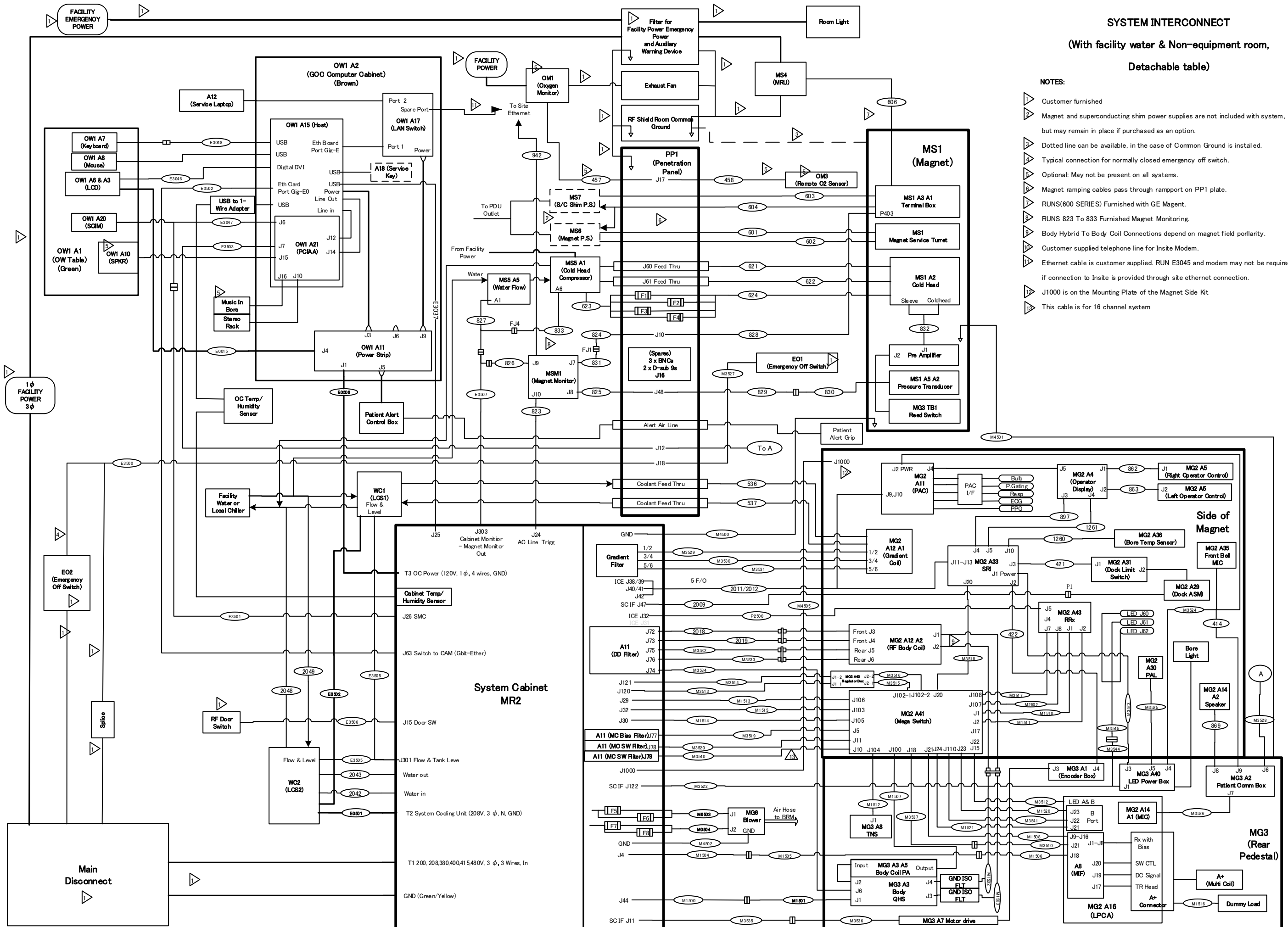

**SYSTEM INTERCONNECT**

(With facility water & Non-equipment room, Detachable table)

- NOTES:**
- 1 Customer furnished
  - 2 Magnet and superconducting shim power supplies are not included with system, but may remain in place if purchased as an option.
  - 3 Dotted line can be available, in the case of Common Ground is installed.
  - 4 Typical connection for normally closed emergency off switch.
  - 5 Optional: May not be present on all systems.
  - 6 Magnet ramping cables pass through rampout on PP1 plate.
  - 7 RUNS(600 SERIES) Furnished with GE Magnet.
  - 8 RUNS 823 To 833 Furnished Magnet Monitoring.
  - 9 Body Hybrid To Body Coil Connections depend on magnet field polarity.
  - 10 Customer supplied telephone line for Insite Modem.
  - 11 Ethernet cable is customer supplied. RUN E3045 and modem may not be required if connection to Insite is provided through site ethernet connection.
  - 12 J1000 is on the Mounting Plate of the Magnet Side Kit
  - 13 This cable is for 16 channel system



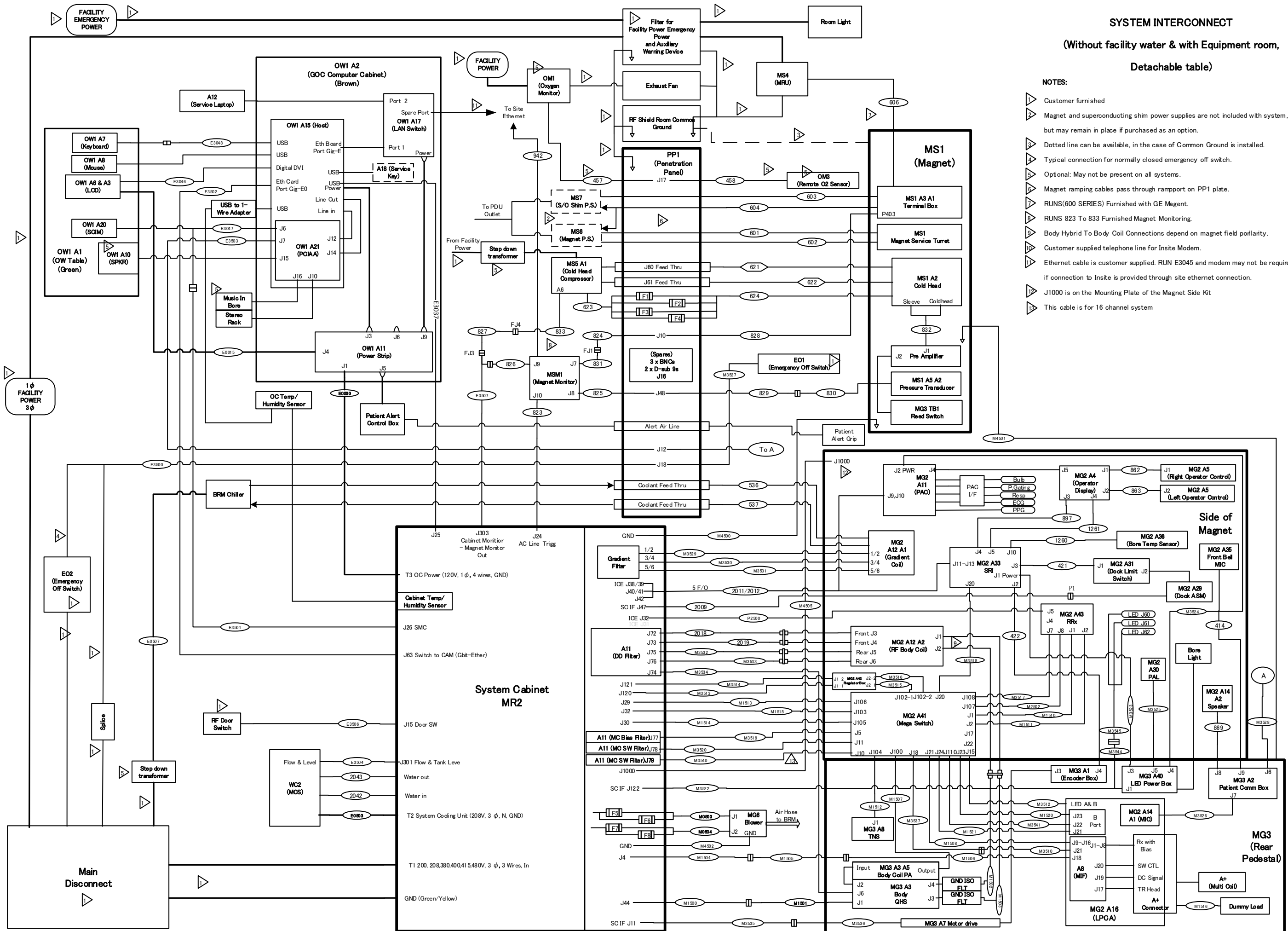

**SYSTEM INTERCONNECT**  
 (Without facility water & with Equipment room,  
 Detachable table)

- NOTES:**
- 1 Customer furnished
  - 2 Magnet and superconducting shim power supplies are not included with system, but may remain in place if purchased as an option.
  - 3 Dotted line can be available, in the case of Common Ground is installed.
  - 4 Typical connection for normally closed emergency off switch.
  - 5 Optional: May not be present on all systems.
  - 6 Magnet ramping cables pass through rampout on PP1 plate.
  - 7 RUNS(600 SERIES) Furnished with GE Magnet.
  - 8 RUNS 823 To 833 Furnished Magnet Monitoring.
  - 9 Body Hybrid To Body Coil Connections depend on magnet field polarity.
  - 10 Customer supplied telephone line for Insite Modem.
  - 11 Ethernet cable is customer supplied. RUN E3045 and modem may not be required if connection to Insite is provided through site ethernet connection.
  - 12 J1000 is on the Mounting Plate of the Magnet Side Kit
  - 13 This cable is for 16 channel system

