

MULTI-NUCLEAR SPECTROSCOPY (1.5T)

TABLE OF CONTENTS

<u>SECTION</u>	<u>PAGE</u>
1 – DESCRIPTION AND INTERCONNECT TABLE	1-1
MULTI-NUCLEAR SPECTRO KIT	1-2
MULTI-NUCLEAR SPECTROSCOPY RF/PEN 1 SIGNAL LOCATIONS	1-4
MULTI-NUCLEAR SPECTROSCOPY RF/PEN 2 SIGNAL LOCATIONS	1-5
MAGNET ROOM INTERCONNECT	1-7
2 – RF/PEN 1 SCHEMATIC INTERCONNECT	2-1
RF/PEN 2 SCHEMATIC INTERCONNECT	2-2
3 – SPECTRO BROADBAND 20 dB GAIN BLOCK	3-1
4 – SPECTROSCOPY PREAMP (Phosphorus)	4-1
5 – THREE BAND LOW PASS FILTER	5-1
6 – FILTER RELAY ASSEMBLY	6-1
7 – SPECTRO TR SWITCH CIRCUIT BOARD (NEW)	7-1
8 – SPECTRO TR SWITCH CIRCUIT BOARD (ORIGINAL)	8-1

SECTION 1 – 1.5T MULTI-NUCLEAR SPECTROSCOPY

This portion of the manual will be changing with the release of 8.3 software. Four MNS Catalogs will be available: M1033MA, MB, MC, and MD. A UCERD and its associated power supply cable and MNS receive cable harness will be required.

Interconnect diagrams for a forward production Signa Horizon LX (8.3 Release) system with the Multi-Nuclear Spectroscopy Subsystem Option are located in this Tab. RF/Pen [1 or 2] Cabinet (MR1) cable connections are shown. Interconnection diagrams of the equipment room and magnet room are also provided for the Multi-Nuclear Spectroscopy Subsystem Option. Table 1-1 identifies the necessary interconnect cables. Table 1-2 refers to the Hardware used with the RF/Pen 1 or RF/Pen 2 Cabinet.

UPGRADES FROM M1040FF/M1040FK:

The Spectro Helix Cable (Run 468) will be re-routed for M1040FF and M1040FK upgrades and connected to the RF/Pen Cabinet (MR1). The Spectroscopy RF Amplifier and associated power cord will be removed from the stand-alone MR6 BroadBand Cabinet and placed in the MR1 RF/Pen Cabinet (MR1). Additionally, Run # 459, 460, 461, 462, 463, 464, 465, and 467 must be removed with the Horizon LX (8.3 Release) upgrades.

UPGRADES FROM M1040JB/M1090JZ:

The Spectro Helix Cable (Run 468) was previously re-routed for upgrades to Signa Horizon. The Spectroscopy RF Amplifier and associated power cord have already been placed in the MR1 RF/Pen Cabinet (MR1). All unnecessary cables have already been removed.

Depending on when the Multi-Nuclear Spectroscopy Subsystem Option was shipped there may be several hardware components that are not available for RF/Pen 1 Cabinet System ONLY. These include the MR1A18 Mechanical Attenuator Assembly and the short BNC style coaxial cable (MR1A18J2-MR1A16J3). Instead, there will be a coaxial cable from MR1A15J104 to MR1A16J3. This is noted in Table 1-1.

TABLE 1-1
SIGNA HORIZON LX (8.3 RELEASE) SPECTROSCOPY OPTION CABLES

RUN	"FROM"	"TO"	DESCRIPTION	REMARKS
229	MR2 A11 J1	MR1 A7 J3	50 ft RG223/U Coax (BNC)	UCERD RF OUT (Narrowband & MNS)
468	MR1 A7 J45	PP1 J83	50 ft Helix Coax (N to SC)	SPECTRO OUT + TR BIAS
469	MR2 A11 J3	PP1 A13 OUT	50 ft RG223/U Coax (BNC)	Spectro Receive (+ 15 VDC RCV Bias)
472	MG3 A11 J3	PP1 A17 J4	80 ft RG223/U Coax (BNC)	Spectro Receive (+ 15 VDC RCV Bias)
473	MG3 A11 J3	PP1 J83	80 ft Helix Coax (SC TO N)	SPECTRO OUT + TR BIAS

MULTI-NUCLEAR SPECTRO KIT W/O AMP, 2109930-11 (540000)

The 2109930-10 Spectro Kit was upgraded with the introduction of the RF/PEN 2 Cabinet. Most cables have been modified in length to accommodate the RF/PEN 2 Cabinet. All items for RF/PEN 2 ONLY have been added. The 2124497-56 cable and the MR1A18 Attenuator are now part of all 2109930-11 Spectro Kits. RF/PEN 1 MNS Systems do not require these additional parts. **All items are a FRU 2 unless otherwise noted. Power line-cords are not specifically set up as a FRU.**

TABLE 1-2
SIGNA HORIZON LX (8.3 RELEASE in RF/PEN 1 or 2 Cabinet) MULTI-NUCLEAR SPECTROSCOPY KIT

“FROM”	“TO”	GE #	VENDOR #	REMARKS
MR1A17 Ground	ERBTEC Ground	2124497-52	540018	SPECTRO GROUND WIRE (to ground studs)
MR1A15J104 MR1A20A1J104	MR1A18J1	2124497-51	540009	SPECTRO RF IN to ATTENUATOR IN
MR1A18J2	MR1A16J3	2124497-56	540031	ATTENUATOR OUT to Spectro Amp RF IN (added with 2109930-11 Kit introduction)
MR1A17J5	MR1A7J45	2124497-47	540004	SPECTRO RF OUT + TR BIAS
MR1A15J507 MR1A20J507	MR1A17J7	2124497-49	540015	SPECTRO I/F CABLE ASSEMBLY (main cable)
MR1A15J407 MR1A20A2J407	MR1A17J4	2124497-55	540008	SPECTRO TR BIAS
MR1A17J3	MR1A15J102 MR1A20A1J102	2124497-54	540007	SPECTRO POWER MONITOR SENSE B
MR1A17J2	MR1A15J101 MR1A20A1J101	2124497-53	540006	SPECTRO POWER MONITOR SENSE A
MR1A17J6	MR1A16J7	2124497-50	540016	BB-I/F CABLE ASSEMBLY (control signals to Spectro Amplifier)
MR1A16J2	MR1A17J1	2124497-48	540005	2 kW RF IN from Spectro Amplifier to Spectro Module Asm.
RF/PEN 2 ONLY All RF/PEN 2 sites will need to adhere the proper label to its associated cable.		2124498-36	401-2007	RF/PEN2 CABLE LABEL KIT (1) MR1A20A1J104 (1) MR1A20J507 (1) MR1A20A2J407 (1) MR1A20A1J102 (1) MR1A20A1J101
RF/PEN 2 ONLY Many RF/PEN2 Cabinets have the proper Rev. See the T/S Tab for details		2124498-37	540034 379-0006 550061 550063	RF/PEN 2 SSM Micro Kit (1) chip puller (1) RF/PEN 2 Only, micro for CPD (U8) (2) RF/PEN 2 Only, micro for APM (U8 and U1)
RF/PEN 2 ONLY Mount Spectro Chimney into RF/Pen 2 Front Cabinet Cover		2124498-38	540035 510198 214-2101 215-2260	RF/PEN2 Chimney Kit (1) Multi-Nuclear Spectro Front Cabinet Cover Chimney. (4) 6-32 nylon insert nuts (8) 4-40 x 3/8 phillips screws
RF/PEN 2 ONLY Mount I/F Bracket at the rear of the Cabinet on right side vertical rail at the bottom		2124498-39	540036 540029 300-7009 300-70091 300-0511 215-2287 216-0010 214-9903	MR1A7, RF/PEN2 SPECTRO I/F ASM (1) Spectro I/F Bracket (1) N Bulkhead Adaptor, F-F,UG-30/U (1) N Lockwasher (1) BNC 50 ohm Pnl Mnt Adapt, D Style & BNC Lockwasher (2) Phillips Panhead SS Screw 10-32 X 1/2 (2) SS Flat Washer #10 (2) rail clips

TABLE 1-2
SIGNA HORIZON LX (8.3 RELEASE in RF/PEN 1 or 2 Cabinet) MULTI-NUCLEAR SPECTROSCOPY KIT

“FROM”	“TO”	GE #	VENDOR #	REMARKS
ALL MR1A18 is mounted on the top right horizontal rail as viewed from the rear		2124498-40	540033 179-2010 540032 215-2243 215-2290	MR1A18, ATTENUATOR KIT (1) 0-10 dB Adjustable Mechanical Attenuator (1) Attenuator Mounting Bracket (2) Atten to bracket mounting screws 6-32 x 1/4 Screw (2) Bracket to side rail mounting screws 1/4-20x 1/2
ALL Amplifier Shelf		2124498-41	540037 510132 215-2529 214-0215	Shelf Assembly (1) SPECTRO SHEETMETAL SHELF (4) Screw, HexHeadCap, 1/4-20 (4) Nut, Hex keps zinc/steel, 1/4-20
ALL Amplifier HWR FRU - NO		2124498-42	540038 214-9903 215-2287	Amplifier Hardware Kit (4) rail clips for Amplifier (4) Phillips Panhead SS Screw 10-32 X 1/2
ALL Silver Box FRU - 1		2124498-27	540001 214-2104 215-2287 216-0010	SPECTRO MODULE ASSEMBLY (MR1A17) (1) 10-32 nylon insert Nut for Ground stud (4) 10-32 X 1/2 screws (4) SS Flat Washer #10

MULTI-NUCLEAR / BROADBAND SPECTRO POWER LINE-CORD

ENI Vendor Part

MR5K-PK-900-50 2 Power Linecord 1 Power Linecord for ENI RF Amplifier, (D. A. Linecord)

ANALOGIC Vendor Part

21-51546 2 Power Linecord 1 Power Linecord for ANALOGIC RF Amplifier

1-1 MULTI-NUCLEAR SIGNALS ON THE CM/PM BOARD IN THE RFSC in the RF/Pen 1 Cabinet

(located near ribbon cables at bottom—all cables must be connected when making measurements)

1.	U16,	PIN 18	AC_ON	High
2.	U16,	PIN 16	FAULT_RESET	Low
3.	U16,	PIN 14	POWER_SHUTDOWN	Low
4.	U16,	PIN 12	UNBLANK_TO_BB	Unblank Signal when pulsing BB
5.	U48,	PIN 15	FIST_1_RTN (phosphorus)	(DC-38MHz) relay selected will be low (pibbandfilt=1)
6.	U48,	PIN 16	FIST_2_RTN(carbon/sodium/lithium)	(DC-24MHz) relay selected will be low (pibbandfilt=2)
7.	U48,	PIN 17	FIST_3_RTN (fluorine)	(DC-64MHz) relay selected will be low (pibbandfilt=0)
8.	U59,	PIN 2	FAULT	Low
9.	U59,	PIN 4	DUTY_FAULT	Low
10.	U59,	PIN 6	POWER_FAULT	Low
11.	U59,	PIN 8	OVERHEAT_FAULT	Low
12.	U59,	PIN 13	AC_ON_READBACK	High
13.	U59,	PIN 17	BOARD_PRESENT	Low

1-2 SPECTROSCOPY BOARD PART NUMBER AND REVISIONS (RF/Pen 1)

Older revisions of the Circuit Boards located in the RF/Pen 1 Cabinet RFSC may present a problems. The Circuit Board part number is listed before the board revision. Part numbers and board revisions vary, however, when experiencing Multi-Nuclear Spectroscopy problems have these numbers ready.

1. CM/PM Board (Communication Manager / Power Monitor Board): 450003.07
2. APB (Analog Processor Board): 450002.05
3. Pin Switch Driver Board: 450158.06

1-3 ASSOCIATED MULTI-NUCLEAR SPECTROSCOPY REVISIONS (RF/Pen 1)

1. EPROM U42, located on the CM/PM Board in the RFSC, should be at least 1.8 Revision.
2. PAL U40, located on the CM/PM Board in the RFSC, should be 6D04.

1-4 MULTI-NUCLEAR SIGNALS ON THE J507 CABLE and the REAR INTERFACE BOARD IN THE SSM of the RF/Pen 2 Cabinet (all cables must be connected when making measurements)

MR1A20 J507	REAR I/F BOARD ROW, PIN	Signal Name	Status	
1.	1	B10, 42	+15 VDC	+15 VDC
2.	2	C10, 74	+15 VDC	+15 VDC
3.	5	A2, 2	GROUND	Low
4.	9	C13, 77	AC_ON	High
5.	10	C15, 79	FAULT_RESET	Low
6.	11	A16, 16	POWER_SHUTDOWN	Low
7.	12	C16, 80	UNBLANK_TO_BB	Unblank Signal to Spectro Amp when pulsing BB
		C11, 75	S-UNBLK-N	Unblank Signal when pulsing BB
		C12, 76	S-UNBLK-P	Unblank Signal when pulsing BB
8.	13	A9, 9	FIST_1_RTN (phosphorus)	(DC-38MHz) relay selected will be low (pibbandfilt=1)
9.	14	B7, 39	FIST_2_RTN(carbon/sodium/lithium)	(DC-24MHz) relay selected will be low (pibbandfilt=2)
10.	15	C9, 73	FIST_3_RTN (fluorine)	(DC-64MHz) relay selected will be low (pibbandfilt=0)
11.	16	C6, 70	FAULT	Low
12.	17	B13, 45	DUTY_FAULT	Low
13.	18	B19, 51	POWER_FAULT	Low
14.	19	A7, 7	OVERHEAT_FAULT	Low
15.	20	B16, 48	BIASON	High
16.	21	C18, 82	AC_ON_READBACK	High
17.	22	B8, 40	BOARD_PRESENT	Low

1-5 SPECTROSCOPY BOARD PART NUMBER AND REVISIONS (RF/Pen 2)

Older revisions of the Circuit Boards located in the RF/Pen 2 Cabinet SSM may present problems for MNS users. The revisions listed below are not a representation of the acceptable board revision because Horizon LX MNS is in its clinical mode. This proper revision data will be available at a later date. The Circuit Board part number is listed before the board revision. Part numbers and board revisions vary, however, when experiencing Multi-Nuclear Spectroscopy problems have these numbers ready to discuss.

1. CPD (Communications PIN Driver Board): 550015.04 (with micro—> U8, checksum FEB5 date 4/19/99).
2. APM (Analog Power Monitor Board): 550013.05 (with micro's—> U8 and U1, checksum EEAE date 3/25/99).

1-6 ASSOCIATED MULTI-NUCLEAR SPECTROSCOPY REVISIONS (RF/Pen 2)

1. Microprocessors: 3 Total sent out with FMI 60525: older rev micros may be sent with the kit, always use the latest date microprocessors.
2. Spectro RF Adjust Circuitry—set R22 pot to minimum and use the MR1A18 Attenuator.

**SIGNA HORIZON LX MULTI-NUCLEAR SPECTROSCOPY INTERCONNECTIONS
(8.X SYSTEMS)**
MAGNET ROOM: PENETRATION PANEL TO MULTI-NUCLEAR SPECTROSCOPY FLEX COIL

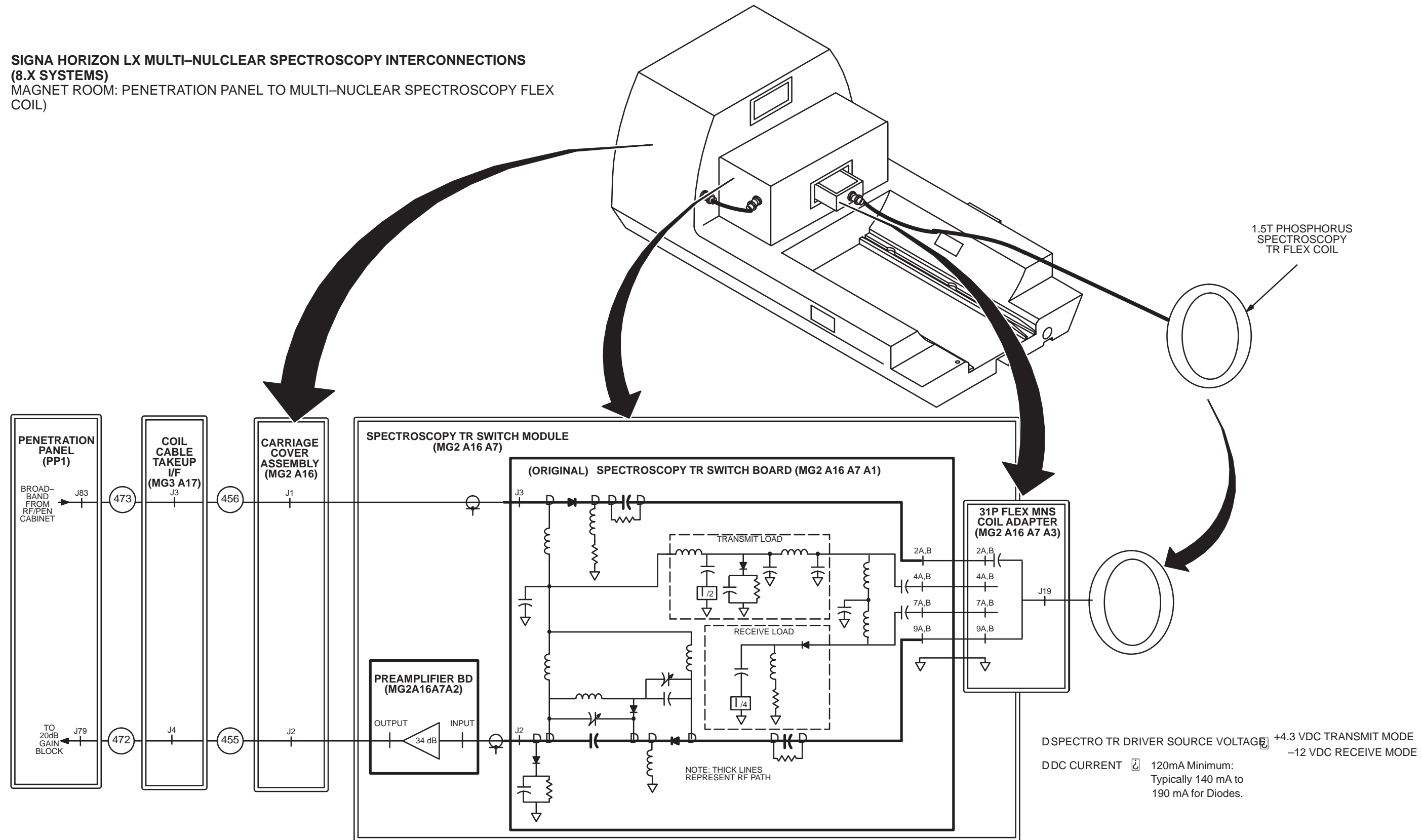

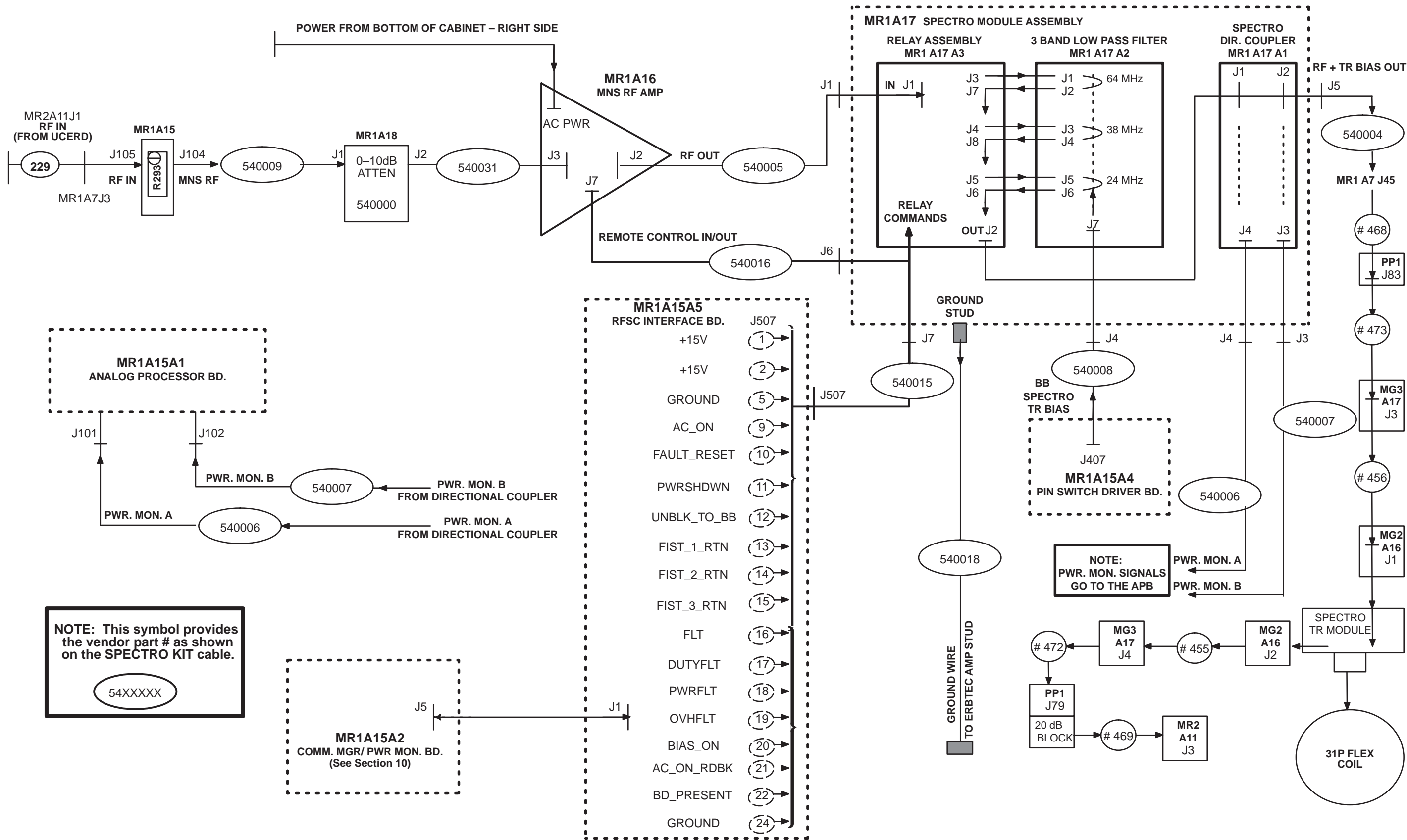

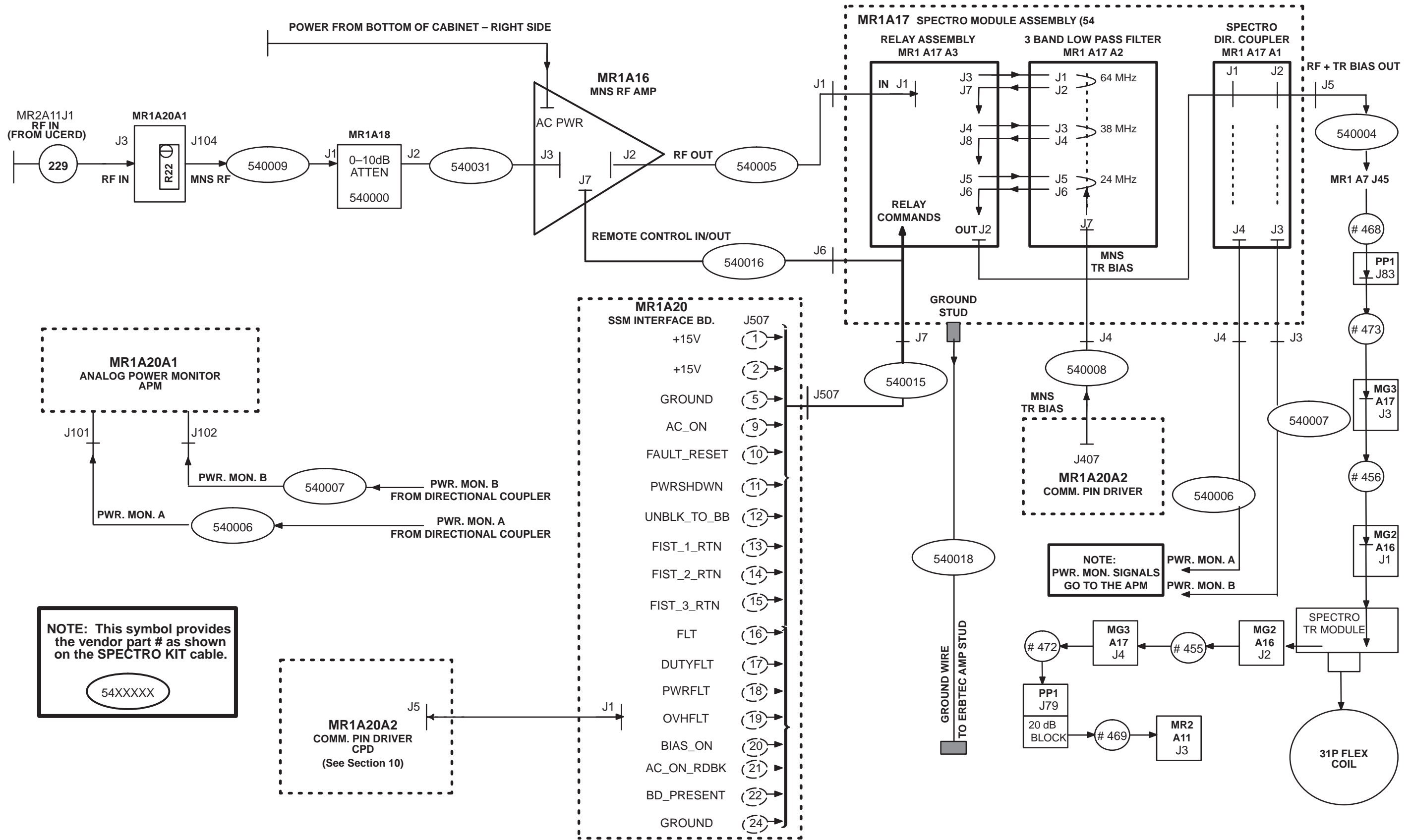

PP1 A13
SPECTRO BROADBAND 20dB GAIN BLOCK

46-264814G1-A

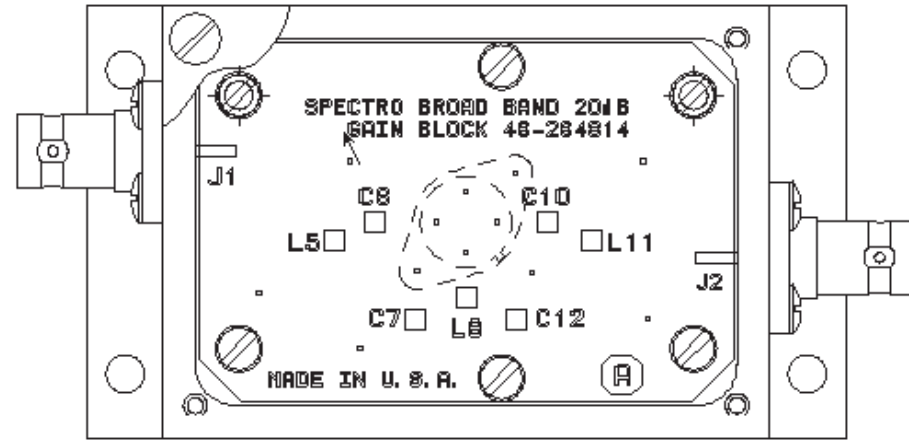

Description

The Spectroscopy BroadBand 20 dB Gain Block was designed to augment receive channel gain from the RF Preamp to the RF Receiver. Located at the Penetration Panel it provides roughly 20 dB of signal amplification at all frequencies of Multi-Nuclear interest while ensuring a total noise figure of less than 1 dB for the composite receive channel. In general, the +15 VDC bias applied to port J2 (Output) enables the active device for proper RF operation over the frequency range. Capacitors C6 and C10 accomplish DC blocking at the input and output of the device while inductors L5, L8, and L11 act as RF chokes. Capacitors C7 and C12 route any residual RF in the DC bypass path to ground. This configuration bridges the DC supply from ports J2 (Output) to J1 (Input) so as to supply DC current to the preamp.

As a continuity check with no bias applied, the DC resistance at ports J1 and J2 to Ground (common) should be observed infinite (1 to 10 Mega-ohms). The resistance measured through the device, J1 center conductor to J2 center conductor, should be observed at 4 to 6 ohms.

EXPLANATION OF +15 VDC PATH TO SPECTRO PREAMP

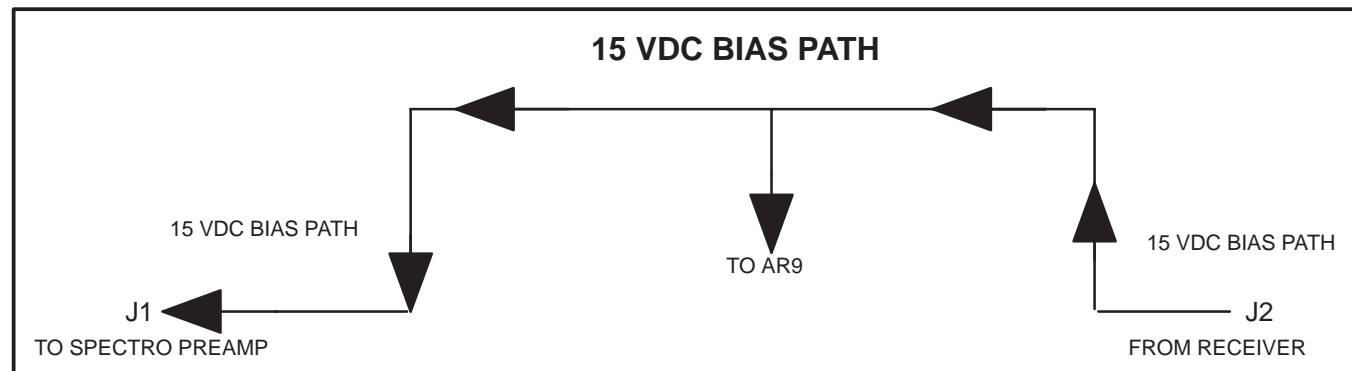

CONT ON SHEET - SHT NO 1
 S-718792-97
 DRAWING NO.

PP1 A13

UNLESS OTHERWISE SPECIFIED USE THE FOLLOWING:-			
APPLIED PRACTICES			

REV A
 46-264814-S
 CONT ON SHEET - SHT NO. 1

GENERAL ELECTRIC
 46-264814-S
 CONT ON SHEET - SHT NO 1
 TITLE
 SCHEMATIC DIAGRAM
 SPECTRO BROAD BAND 20dB GAIN BLOCK
 FIRST MADE FOR MR
 P/L ISSUED

46-264814G1-A

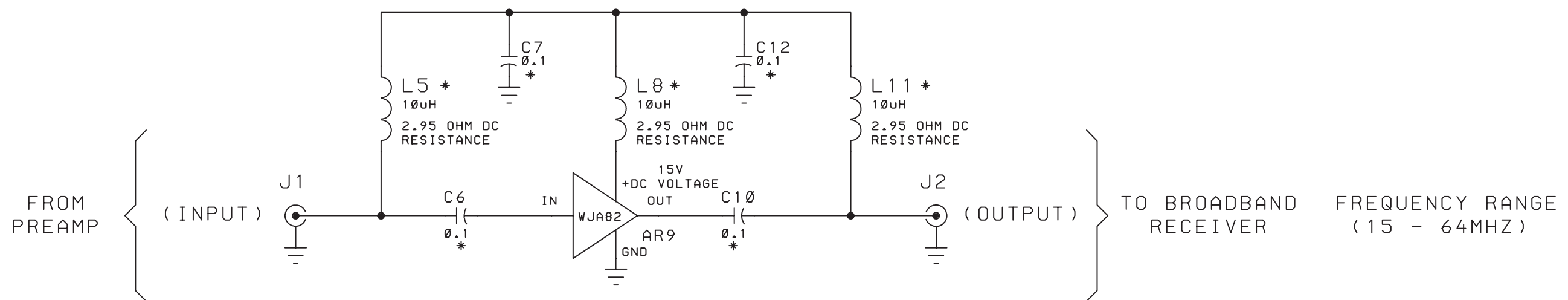

NOTES:
 1. UNLESS OTHERWISE SPECIFIED:
 ALL CAPACITORS ARE IN MFD.
 2. "*" INDICATES SURFACE MOUNTED COMPONENT.

ALL DEVICES SHOWN TOP VIEW

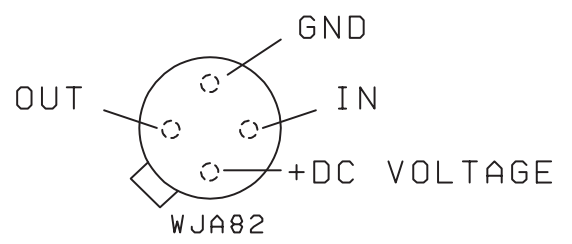

REVISIONS		PRINTS TO	
		740	

MADE BY G. TESKE 18MAR89	APPROVALS	MEDICAL SYSTEMS DEPT MILWAUKEE, WI LOCATION	DIV OR 46-264814-S
ISSUED			CONT ON SHEET - SHT NO. 1

MG2 A16 A7 A2 SPECTROSCOPY PREAMP (Phosphorus)

46-264862G1-B

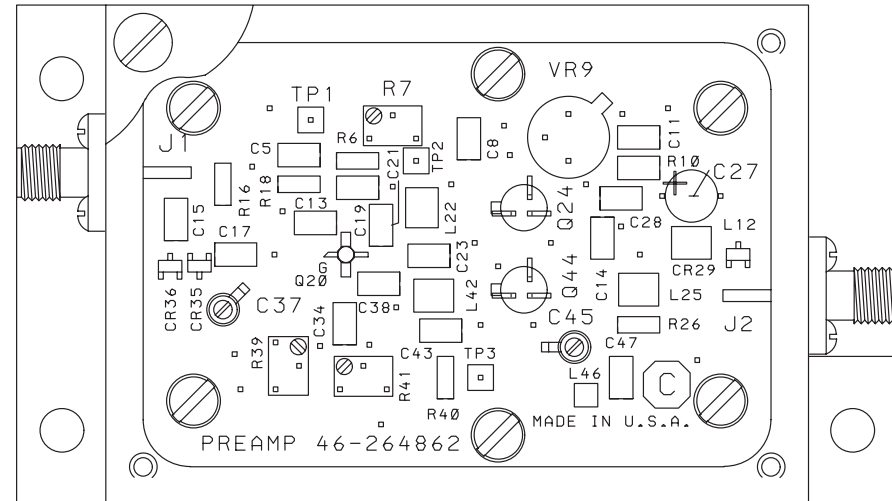

Description

The preamp provides the first stage of amplification for the MR signal in the receive path. The preamp is part of the Spectroscopy TR Module which is placed at the front of the head carriage slide trolley when Multi-Nuclear scanning is selected. The J2 RF output port of the preamp requires +15 VDC, $\pm 10\%$ @ 100 mAmps. The +15 VDC preamp bias originates in the Systems Cabinet TPS Power Supply and is supplied to the Receiver Board and BB Receiver Module via the backplane. The Spectroscopy AUX port preamp bias will measure +15 VDC after a BroadBand Spectroscopy protocol is selected and pulsed once. The spectroscopy preamp bias is sent down the selected AUX receive coaxial cable to power the 20 dB gain block and the preamp. The total nominal gain of the preamp is +35 dB, ± 3 dB, this gain can be measured by injecting an RF signal at the specified frequency with a maximum level of -10 dBm (nominally this is -30 dBm). The noise figure should be less than 0.5 dB.

CONT ON SHEET - SHT NO. 1
 46-264862-S
 ON SHEET - SHT NO. 1

UNLESS OTHERWISE SPECIFIED USE THE FOLLOWING:-
 APPLIED PRACTICES
 46-208600

REV AB
 46-264862-S
 CONT ON SHEET - SHT NO. 1

TITLE
 SCHEMATIC DIAGRAM
 SPECTROSCOPY PREAMP (PHOSPHORUS)
 FIRST MADE FOR MR

46-264862-S
 CONT ON SHEET - SHT NO. 1

MG2A16A7 A2

46-264862G1-B

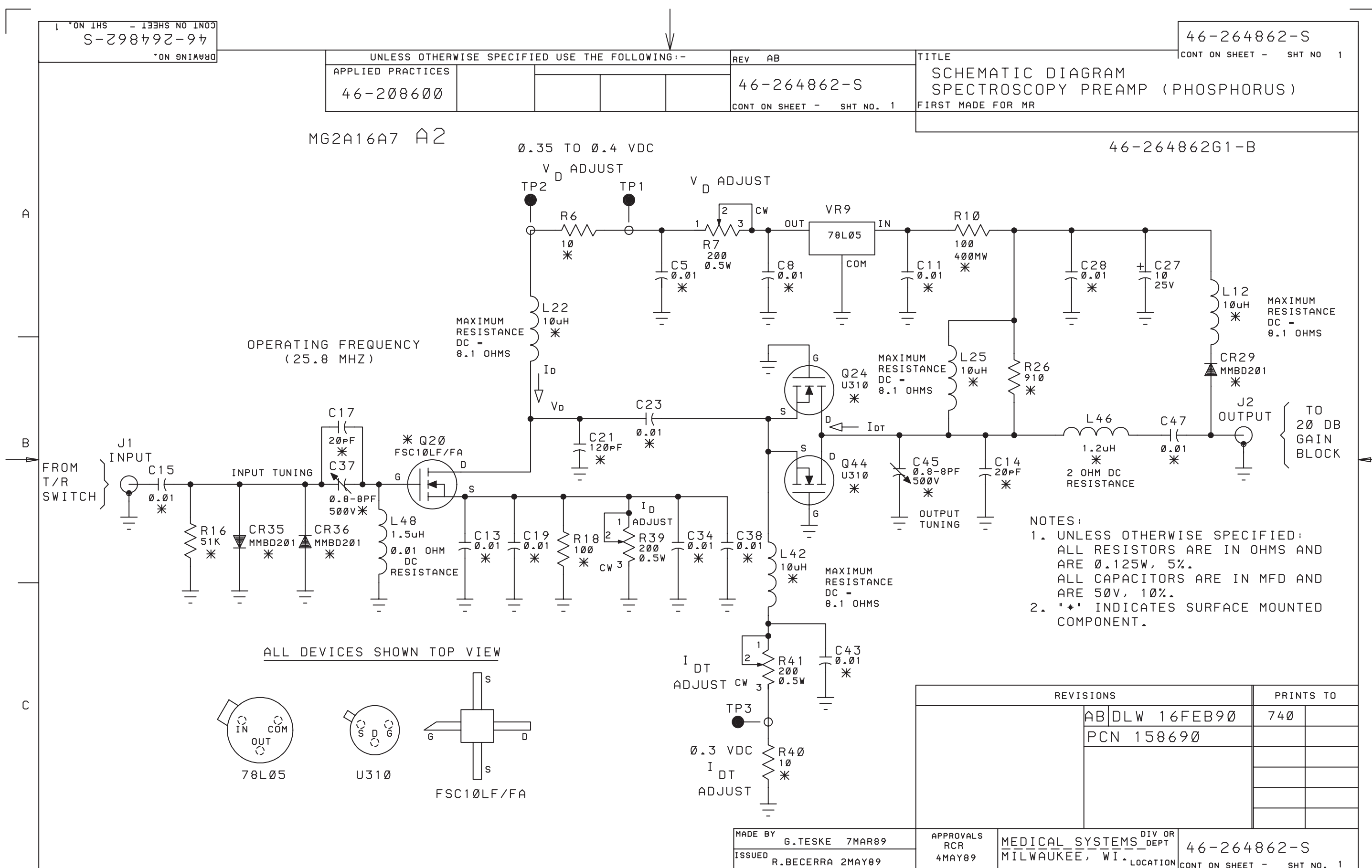

OPERATING FREQUENCY
 (25.8 MHZ)

MAXIMUM RESISTANCE
 DC = 8.1 OHMS

MAXIMUM RESISTANCE
 DC = 8.1 OHMS

MAXIMUM RESISTANCE
 DC = 8.1 OHMS

MAXIMUM RESISTANCE
 DC = 8.1 OHMS

- NOTES:
- UNLESS OTHERWISE SPECIFIED:
 ALL RESISTORS ARE IN OHMS AND
 ARE 0.125W, 5%.
 ALL CAPACITORS ARE IN MFD AND
 ARE 50V, 10%.
 - "*" INDICATES SURFACE MOUNTED
 COMPONENT.

ALL DEVICES SHOWN TOP VIEW

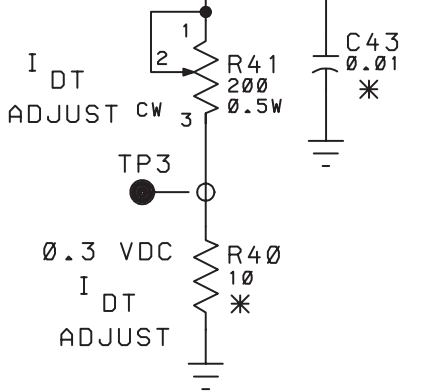
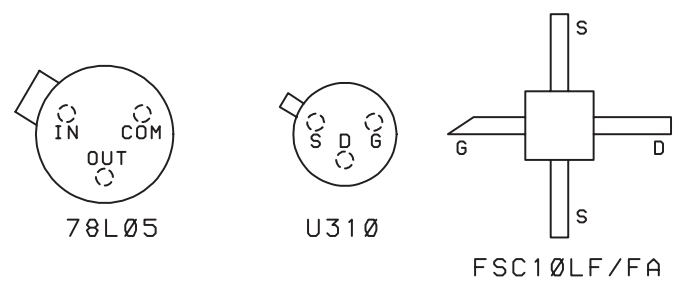

REVISIONS		PRINTS TO	
AB	DLW 16FEB90	740	
PCN	158690		

MADE BY G.TESKE 7MAR89
 ISSUED R.BECERRA 2MAY89
 APPROVALS RCR 4MAY89
 MEDICAL SYSTEMS DIV OR DEPT MILWAUKEE, WI LOCATION
 46-264862-S
 CONT ON SHEET - SHT NO. 1

46-264862-S

MR6 A2 A2
THREE BAND LOW PASS FILTER

46-264866G1-B

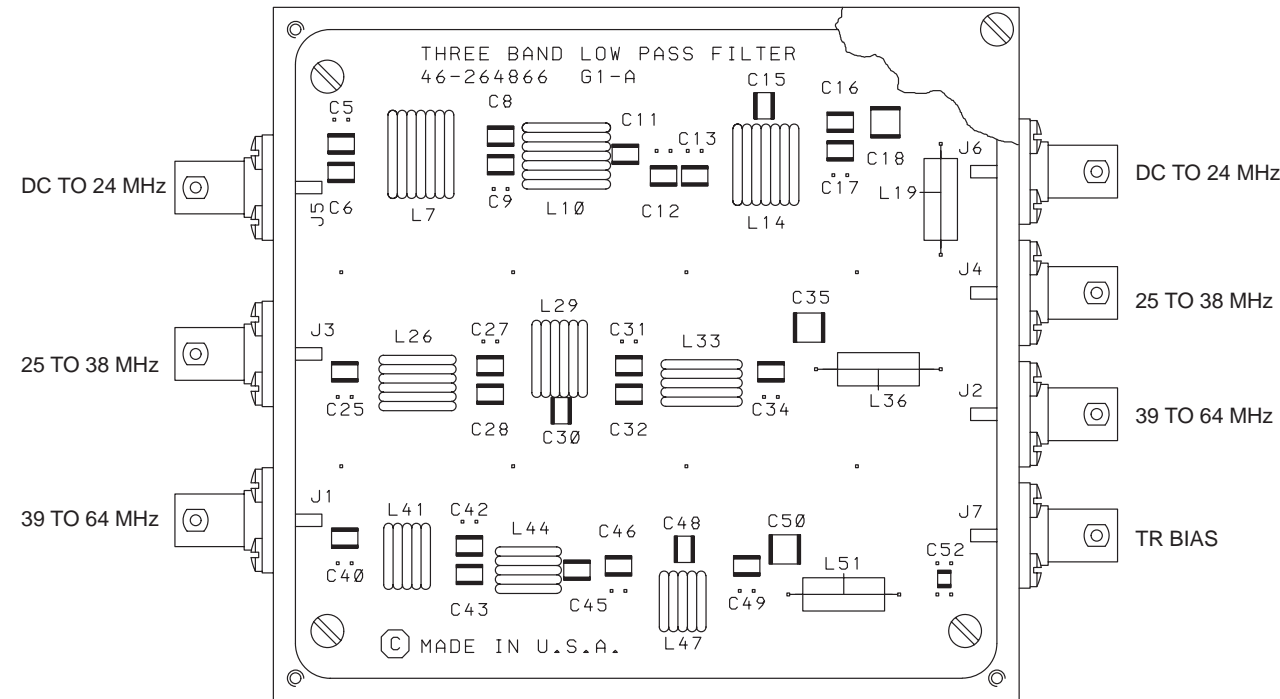

Description

The Three Band Low Pass Filter is used to remove the harmonics at the output of the Spectroscopy RF amplifier. The Three Band Low Pass Filter has three independent low pass filters. A set of relay switches select which of the three frequency bands the RF will pass through.

The first band (25 MHz) has input J5 and output J6. The loss within the pass-band (DC to 24 MHz) is \leq 0.25 dB. The stop-band has a minimum attenuation of 40 dB for frequencies greater than 50 MHz.

The second band (40 MHz) has input J3 and output J4. The loss within the pass-band (DC to 38 MHz) is \leq 0.25 dB. The stop-band has a minimum attenuation of 40 dB for frequencies greater than 80 MHz.

The third band (64 MHz) has input J1 and output J2. The loss within the pass-band (DC to 64 MHz) is \leq 0.25 dB. The stop-band has a minimum attenuation of 40 dB for frequencies greater than 130 MHz.

The remaining connector J7 is used to introduce the DC bias for the Spectroscopy TR Switch Module. This DC bias originates in the RF Cabinet as the Spectro TR Bias signal and is controlled by the unblank signal.

FILTER RELAY

46-301704S

Description

The Filter Relay Assembly is controlled through the software selection of the frequency and/or nuclei. The RF enters into the Assembly at a common point and exits the Assembly at a common point. Three sets of relays are available which directly correspond to three frequency sensitive Low-Pass Filter networks. The Filter Relay Assembly essentially steers the Multi-Nuclear Spectroscopy RF signal to the proper frequency sensitive circuitry (3 Band Low-Pass Filter).

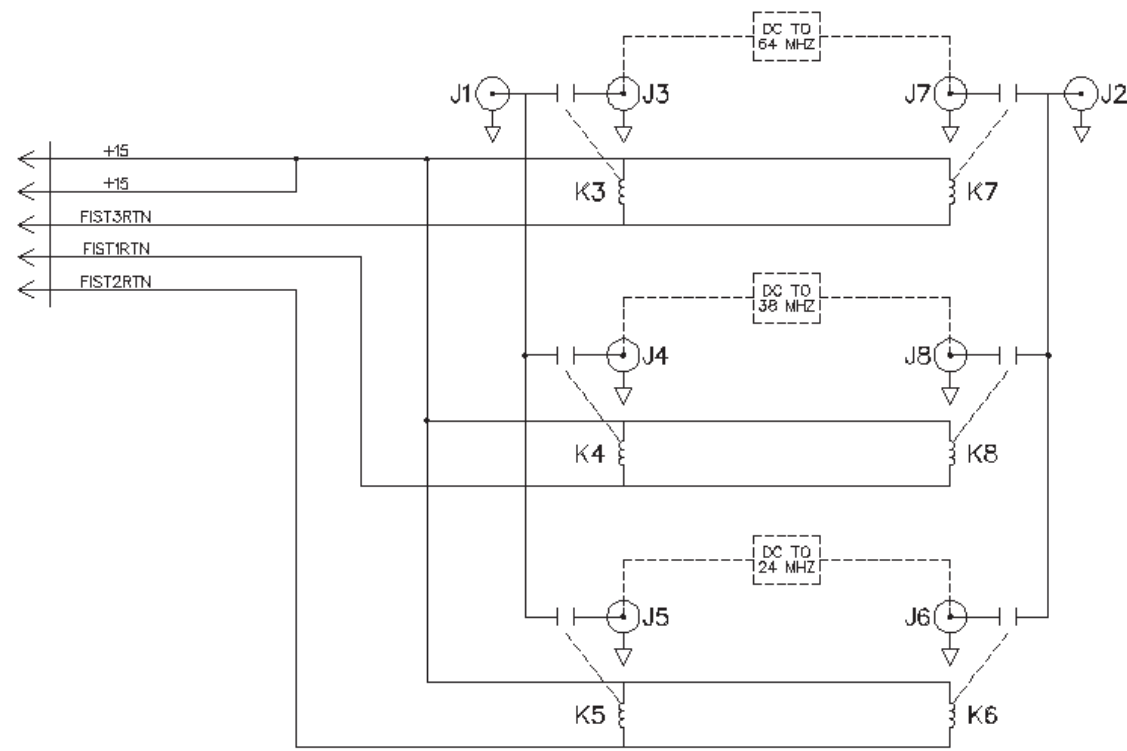

FILTER RELAY ASSEMBLY/3 BAND LOW PASS FILTER

MG2 A16 A7 A2
SPECTRO TR SWITCH

46-321316G1-B

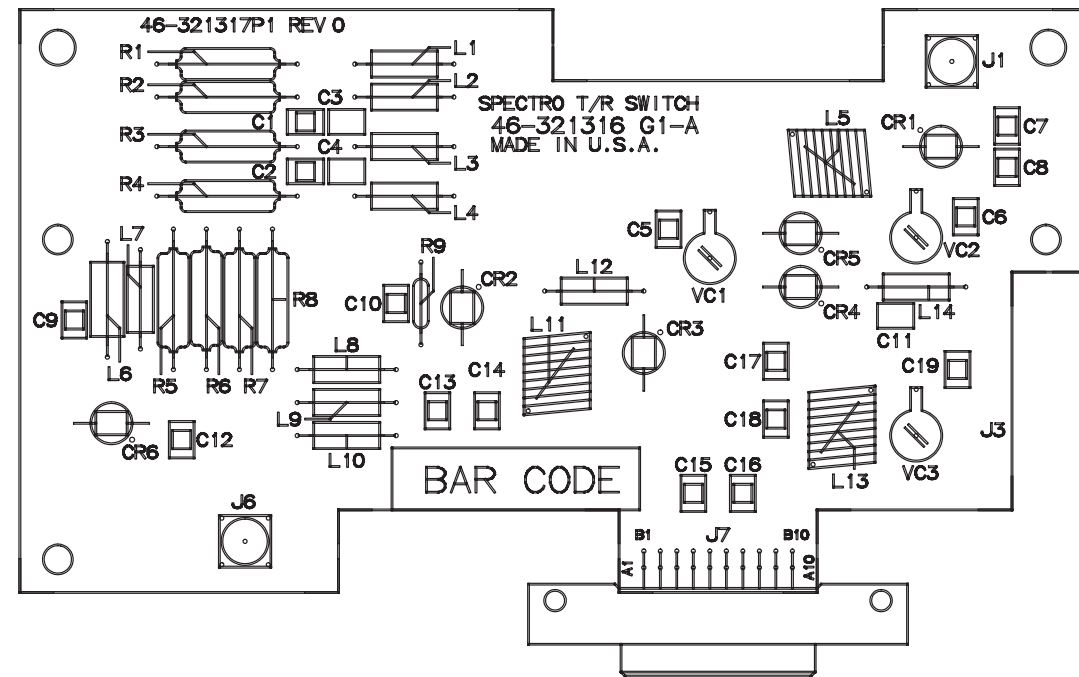

Description

Located in the Multi-Nuclear Spectroscopy TR Module the New Spectroscopy TR Switch is used to switch the between the transmit and receive modes. The UNBLANK signal drives the TR Bias voltage mode. A bias voltage that originates from the TR Driver circuitry (under UNBLANK control) in the RFSC is used to either forward or reverse bias PIN diodes. When transmitting, a positive voltage is supplied via the transmit heliax. This forward biases the PIN diodes which in turn connect the transmitter to the coil. It also shorts the input to the preamplifier, which protects it from being damaged by the high level of RF present during the transmit cycle. When receiving, a negative voltage is supplied is supplied via the transmit heliax. This reverse biases the PIN diodes which in turn disconnects the transmit heliax from the coil and connects the preamplifier to the coil.

REVISION	PCN NUMBER	DATE	SIGN OFF
0	-----	27 / OCT / 93	

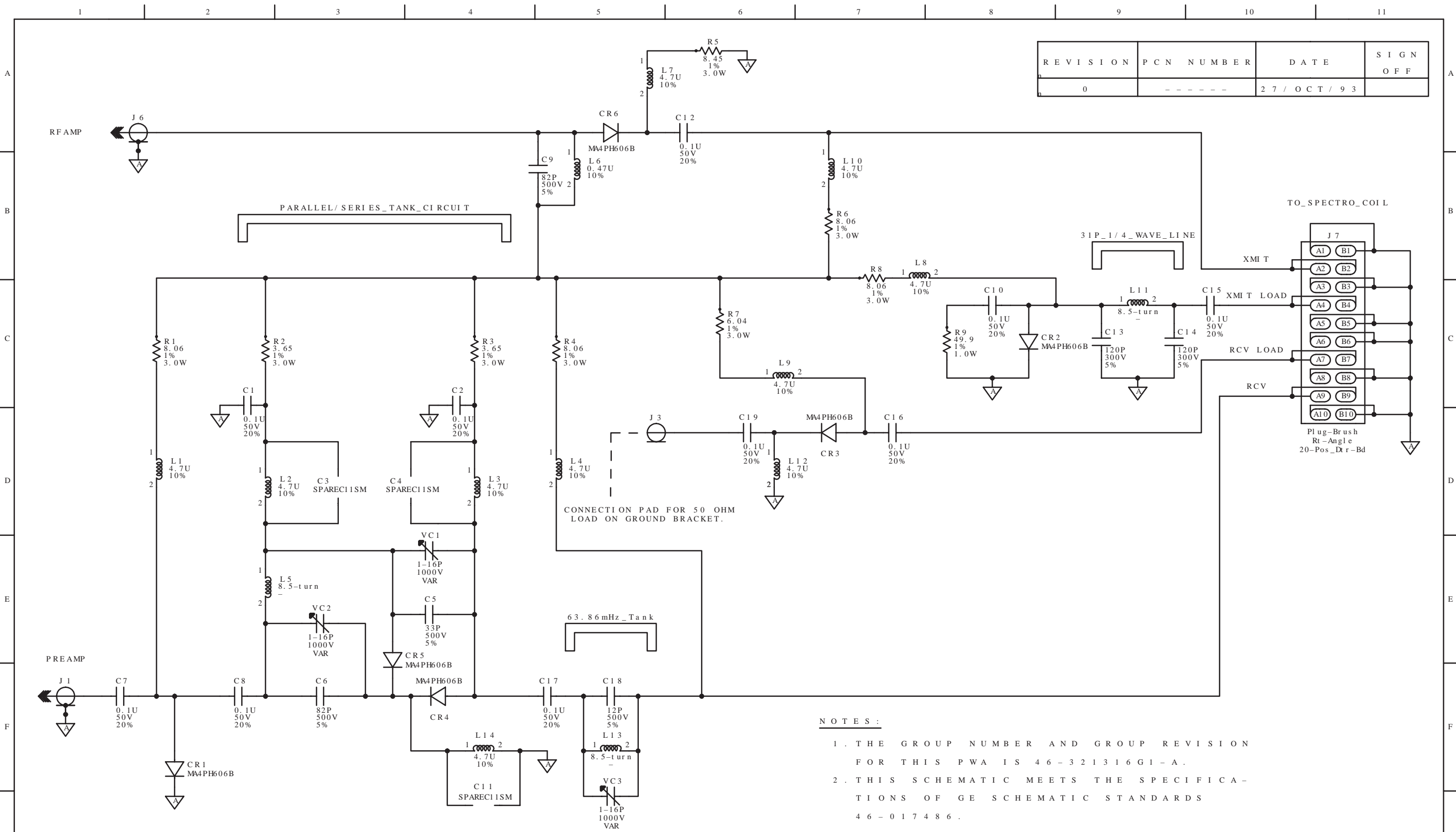

NOTES :

1. THE GROUP NUMBER AND GROUP REVISION FOR THIS PWA IS 46-321316G1-A.
2. THIS SCHEMATIC MEETS THE SPECIFICATIONS OF GE SCHEMATIC STANDARDS 46-017486.
3. UNLESS OTHERWISE SPECIFIED:
RESISTORS ARE IN OHMS
CAPACITORS ARE IN FARADS.
INDUCTORS ARE IN HENRIES.

BLOCK PATHNAME		/user/body_hyb/spectr_sw SHEET 1 OF 1			
REV 0	SPECTRO T/R SWITCH	LOCATION CODE	APPROVALS	GE MEDICAL SYSTEMS	REVISIONS
DRAWING NO. 46-321316-S	FIRST MADE FOR MRSPECT4.5 (31P)	MG2-A16-A7-A1		MILWAUKEE WI	
MADE BY Bill Kostolni	DATE 27-OCT-93	ISSUED	DATE	PRINTS TO 740	

**MG2 A16 A7 A2
SPECTRO TR SWITCH**

46-264762G1-B

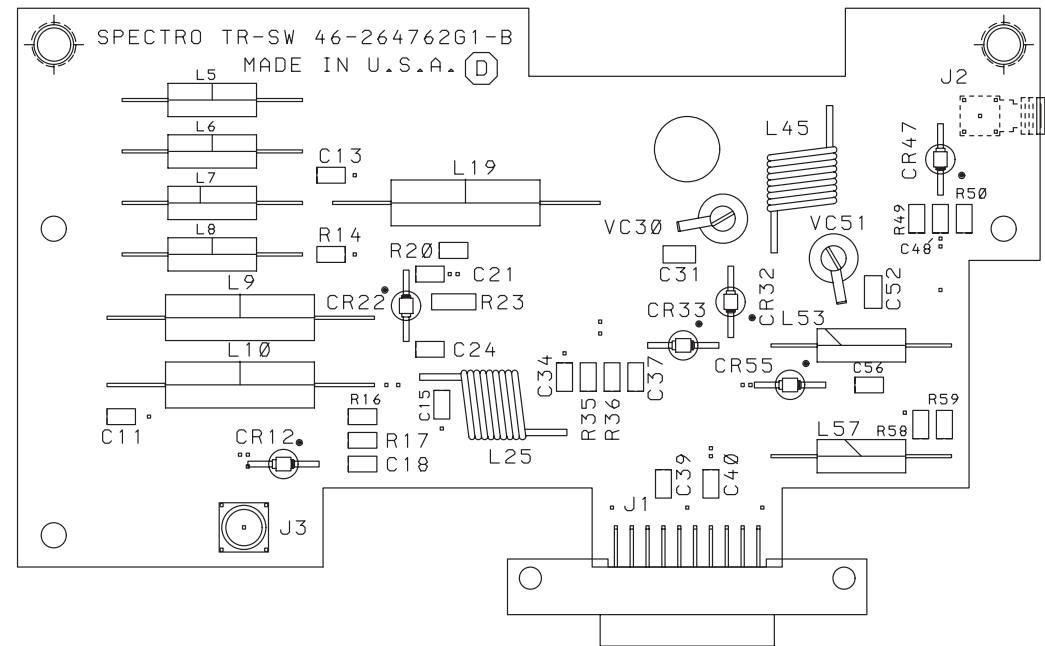

Description

Located in the Spectroscopy TR Module the Original Multi-Nuclear Spectroscopy TR Switch is used to switch the between the transmit and receive modes. The UNBLANK signal drives the TR Bias voltage mode. A bias voltage that originates from the TR Driver circuitry (under UNBLANK control) in the RF/Pen Cabinet is used to either forward or reverse bias PIN diodes. When transmitting, a positive voltage is supplied via the transmit heliax. This forward biases the PIN diodes which in turn connect the transmitter to the coil. It also shorts the input to the preamplifier, which protects it from being damaged by the high level of RF present during the transmit cycle. When receiving, a negative voltage is supplied via the transmit heliax. This reverse biases the PIN diodes which in turn disconnects the transmit heliax from the coil and connects the preamplifier to the coil.

MG2 A16 A7 A2

UNLESS OTHERWISE SPECIFIED USE THE FOLLOWING--		REV	AC
APPLIED PRACTICES		46-264762-S	
46-208600		CONT ON SHEET - SHT NO. 1	

TITLE		46-264762-S	
SCHEMATIC DIAGRAM		CONT ON SHEET - SHT NO. 1	
SPECTRO T/R SWITCH			
FIRST MADE FOR MR SPECT 4.5			

46-264762G1-B

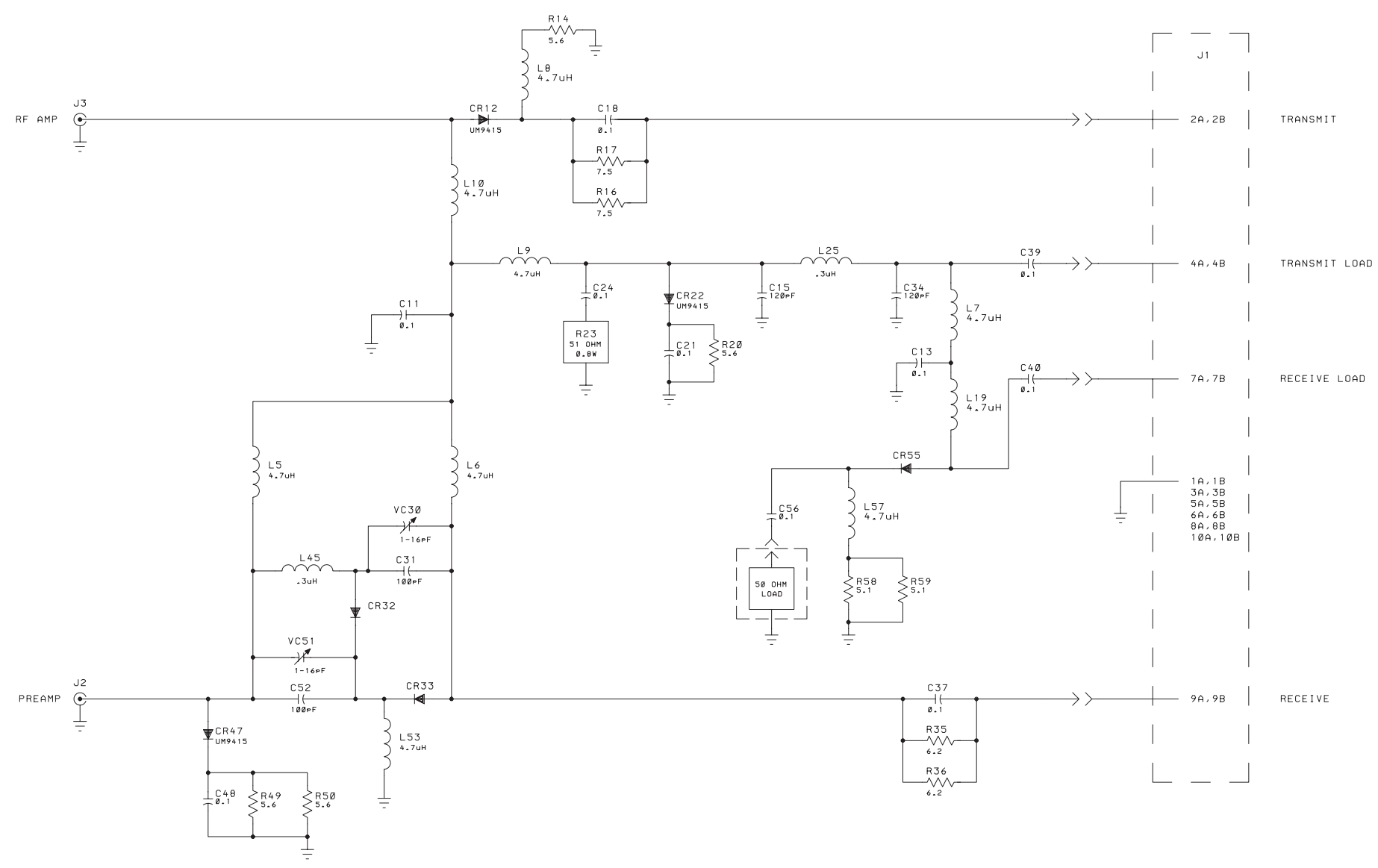

NOTES:
1. UNLESS OTHERWISE SPECIFIED:
ALL CAPACITORS ARE IN MFD.
ALL DIODES ARE UM7001E.
ALL RESISTORS ARE 0.4W, 5%
AND ARE IN OHMS.

REVISIONS		PRINTS TO	
B	DLW 12JUN89	740	
GEN. CHNGS.			
AB	DLW 20FEB90		
PCN	158677		
AC	FEP 12FEB91		
PCN	171522		

MADE BY	G. TESKE 17MAY89	APPROVALS	RCH 20OCT89	MEDICAL SYSTEMS DIV DEPT MILWAUKEE, WI	46-264762-S
ISSUED	R. BECERRA 18OCT89				CONT ON SHEET - SHT NO. 1