

APPENDIX C - PROPRIETARY SOFTWARE

TABLE OF CONTENTS

<u>SECTION</u>	<u>TITLE</u>	<u>PAGE</u>
C-1	LOADING/REMOVING PROPRIETARY SOFTWARE (HORIZON 5.X).....	C-2
	C-1-1 Loading MR Service Tape Software	C-2
	C-1-2 Loading HPS Software.....	C-3
	C-1-3 Loading Sun Diagnostic Executive	C-3
C-2	SECURITY KEY (HORIZON 5.X).....	C-3
	C-2-1 Service Person Key (Row One).....	C-4
	C-2-2 Option Keys (Rows Two And Three)	C-4
	C-2-3 In-House And Insite Service Key (Row Four).....	C-4
C-3	REMOVING PROPRIETARY DIAGNOSTICS (HORIZON 5.X).....	C-5
C-4	LOADING/REMOVING PROPRIETARY SOFTWARE (RELEASE 8.X).....	C-5
	C-4-1 Proprietary Software Install.....	C-5
	C-4-2 Loading GE Restricted Software.....	C-6
	C-4-3 In-House Service (Advanced Service Package Limited License Sites)	C-6
C-5	DELETING PROPRIETARY SOFTWARE AND TOOLS (RELEASE 8.X, 9.X, & 10.X)	C-6

C-1 LOADING/REMOVING PROPRIETARY SOFTWARE (HORIZON 5.X)

C-1-1 Loading Mr Service Tape Software

The MR Service Tape contains proprietary MR software and diagnostics for the entire system except the Sun Computer. This section describes how to load the MR Service Tape diagnostics and software tools.

- At the Tape Drive, insert the release compatible MR Service Tape (refer to Table C-1). The Tape Drive lights will blink for approximately 15-25 seconds. The Tape Drive is ready when the lights stop blinking.

TABLE C-1
SOFTWARE TAPE COMPATIBILITY MATRIX

SIGNA HORIZON SERVICE TAPE	DAT
MR RES SRV TAPE (Available to GE Service personnel only)	46-328229G9 (Release 5.6) 46-328229G10 (Release 5.7)
MR ADV SRV TAPE (For customers with Adv. Service Limited License)	46-328228G9 (Release 5.6) 46-328228G10 (Release 5.7)

- At the console, press **(L1) (B)** at the same time to open a "window". Continue per Table C-2.

TABLE C-2
LOADING SIGNA HORIZON C CLASS TOOLS

OUTPUTS/PROMPTS	INPUTS/COMMENTS
<p>Log in to the system as "root":</p> <pre>genesis @ <system id>:..... password:</pre> <p>root @ <system id>:.....</p> <hr/> <p>In ~ 1 minute, the following menu is displayed for the MR RES SRV Tape:</p> <pre>Optional Tape Installation Load Insite Software Load MR Advanced Service Software and Protocols Load MR OC Advanced Service Software Load MR OC Advanced Service Protocols Load MR Show System Package Enter selection number of 'q' to quit:.....</pre> <p>In ~ 1 minute, the following menu is displayed for the MR RES SRV Tape:</p> <pre>Optional Tape Installation Load MR Advanced Service Software and Protocols Load MR OC Advanced Service Software Load MR OC Advanced Service Protocols Enter selection number of 'q' to quit:.....</pre> <hr/> <p>A proprietary warning message page is displayed. To continue, type</p> <p>When tape loading completes (~ 7minutes), the following is displayed:</p> <pre>'2.Load MR Advanced Service Software and Protocols' loaded success Press <enter> to continue Enter selection number or 'q' to quit:</pre> <pre>root @ <system id>:</pre> <pre>genesis @ <system id>:</pre>	<pre>su <ENTER> #bigguy <ENTER> (Release 5.6/5.7 default) installOptTape <ENTER></pre> <hr/> <p>(If selection 5 present, <u>don't load it!</u> Note 1)</p> <pre>2 <ENTER></pre> <hr/> <pre>1 <ENTER></pre> <hr/> <pre><SHIFT> P? <ENTER></pre> <hr/> <pre>q <ENTER> exit <ENTER></pre>

Note 1: This demonstration software interferes with normal product functions and requires a Load From Cold to remove it.

C-1-1 Loading MR Service Tape Software (continued)

- Remove tape from Tape Drive (it takes approximately 10-25 seconds for the tape to be ejected after pressing the eject button on the Tape Drive).

C-1-2 Loading HPS Software

Note

HPS software is loaded with the 5.X proprietary software procedure.

C-1-3 Loading Sun Diagnostic Executive

For details on loading/running SunDiagnostic Executive on the Computer Subsystem, refer to *Direction 2187583-1, MR Service Methods*, Computer.

C-2 SECURITY KEY (HORIZON 5.X)

A Security Key enables the system software to run purchased options, proprietary diagnostics and tools and provide InSite access to the Signa System. The number of Security Keys required vary depending on the number of options.

There are three types of Security Keys: Service Person Keys, Options Keys, and In-House Service Keys. Each type is inserted into different rows of slots of the Security Board as shown in Illustration C-1.

Security Keys are inserted into the Security Board in the leg of the Console as shown in Illustration C-2.



The pins on the Security Keys can be bent if a Key is not inserted carefully. Bent pins destroy the functionality of the Key. Take care to align the Key with the socket during insertion.

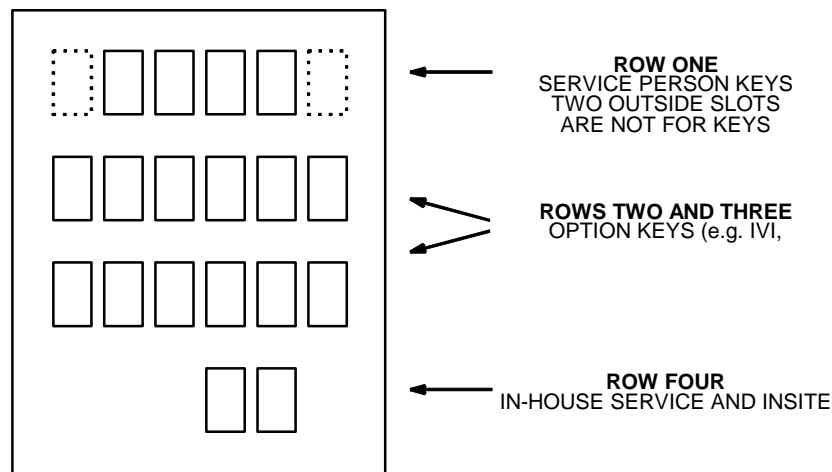

SECURITY BOARD KEY SLOT ASSIGNMENTS
 ILLUSTRATION C-1

C-2 SECURITY KEY (HORIZON 5.X) (continued)

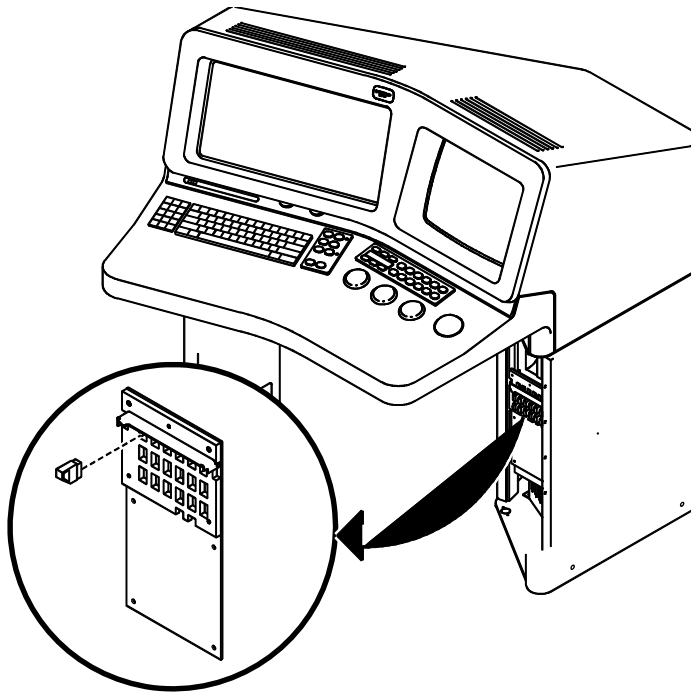

- STEP 1**
REMOVE FRONT COVER
OF CONSOLE PEDESTAL
- STEP 2**
LOCATE PROPER KEY SLOT
- STEP 3**
INSERT KEY INTO SOCKET
PRESS FIRMLY

M3724A

SERVICE PERSON KEY LOCATION
 ILLUSTRATION C-2

C-2-1 Service Person Key (Row One)

A Service Person Key (46-306603G1) is needed to run proprietary diagnostics. The key can be inserted in any of the four center slots in the top row. The key must be in place for a minimum of ten seconds before attempting to run proprietary diagnostics. To install the Service Person Key, lift the cover bar to expose the top row of sockets. When finished performing proprietary diagnostics, remove the Service Person Key and replace the cover on the pedestal.

Note

Remove the Service Person Key before replacing the Console Pedestal Cover. If not removed, damage will occur to the key and/or key socket.

C-2-2 Option Keys (Rows Two And Three)

Option Keys are used to enable various options of the MR Signa Horizon/LX System (e.g. Interactive Vascular Imaging (IVI) option, CINE option, Fast Spin Echo, MR Research Mode, MR Spectroscopy and MR MVP). These keys are inserted into any slot in the two middle rows of slots (these rows have six slots each). After insertion, the key is required to be in place for the option to work. Some keys require a power cycle to initialize. Other hardware is also required for some options. Refer to the installation procedures of each option for proper hardware and software configurations.

C-2-3 In-House And Insite Service Key (Row Four)

The In-House Service Key row (bottom row, two slots) is reserved for the In-House Service Key and the InSite Key. The In-House Service Key (46-317275G1) is used for customer in-house service personnel. The InSite Key enables the InSite feature which allows GE Service to login remotely and access data and perform diagnostics. The InSite feature does require additional hardware for operation (modem, phone line, etc.).

C-3 REMOVING PROPRIETARY DIAGNOSTICS (HORIZON 5.X)

Once on the system, the CClass and HPS software is protected by a “Security” Key. For in-warranty and service contract customers, this proprietary software may be loaded onto the customer’s system following a Load From Cold, and can remain on the system between service calls (the Service Person Key, however, **must** be removed after each service call). **When the customer discontinues having service provided by GE, the proprietary software must be deleted from the customer’s system.**

In order to remove all proprietary diagnostics from the system disk, perform these steps.

1. From the Genesis applications screen, select **[UTILITIES]**.
2. A proprietary statement will be displayed. Enter **[1] [2] [3]** as prompted.
3. Select **[System Utility]**.
4. Select **[Secure]**.
5. Select **[Yes]** when prompted “Delete Proprietary Software?”.

All proprietary diagnostics will be removed from the system disk (in approximately 2 minutes).

C-4 LOADING/REMOVING PROPRIETARY SOFTWARE (RELEASE 8.X)

This procedure shows how to install and un-install proprietary software. In addition, it shows how to secure a system before you leave a site that does not have a proprietary agreement.

Installing proprietary software is done with the click of the mouse. A graphical user interface, or GUI, is used to direct you through the installation and un-installation of this software. In addition, this same GUI allows the site to be secured by clicking on a mouse button.

The Install GUI is located on the service desktop.

C-4-1 Proprietary Software Install

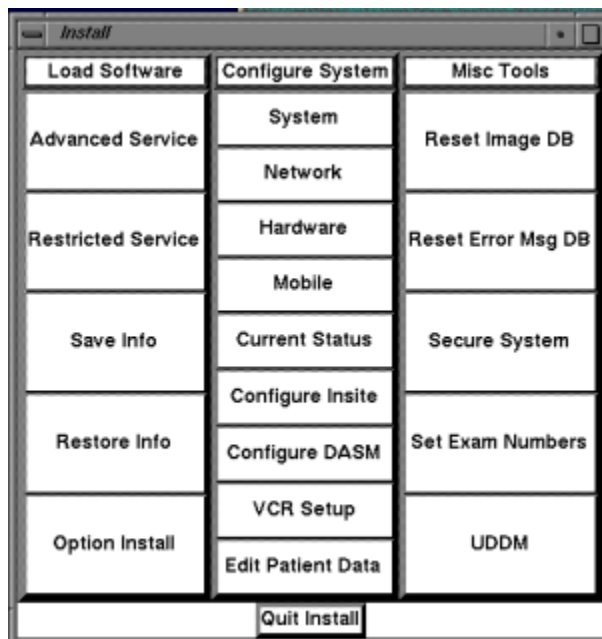

To open the Install GUI, click on the **[Utilities]** icon from the Service Desktop control panel. From the Service Desktop select **[Install]**. The window called Install Tool opens. In the window called “Install Tool”, type **operator <Enter>** at the password prompt. The Install menu will then open.

C-4-2 Loading GE Restrcted Software

Place the appropriate Restricted Service Software CD-ROM in the SGI Host CD-ROM Drive. Click on **[Restricted Service]** button on the Install menu. Follow the directions printed in the Exec window that opens.

Note

When the Exec window opens a GE proprietary statement will display stating to enter **[Shift P ?]** **[Enter]** to continue. If the at the bottom of this screen “stdin Enter” is seen, push the keyboard **[Enter]** key then **[Shift P ?] [Enter]** to continue.

C-4-3 In-House Service (Advanced Service Package Limited License sites)

Place the appropriate Advanced Service Software CD-ROM in the SGI Host CD-ROM Drive. Click on **[Advanced Service]** button on the Install menu. Follow the directions printed in the Exec window that opens.

C-5 DELETING PROPRIETARY SOFTWARE AND TOOLS (RELEASE 8.X, 9.X, &10.X)

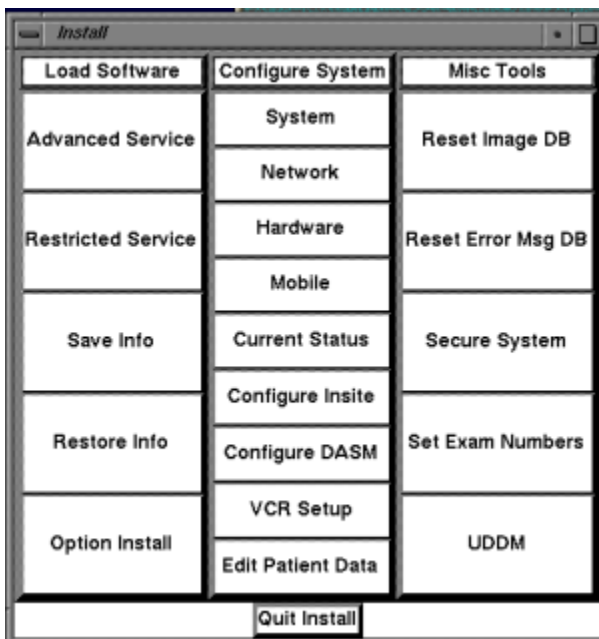

To open the Install GUI, click on the **[Utilities]** icon from the Service Desktop control panel. From the Service Desktop select **[Install]**. The window called Install Tool opens. In the window called “Install Tool”, type **operator <Enter>** at the password prompt. The Install menu will then open.

From the Install menu click **[Secure System]**. The system requires confirmation. In the Confirm dialog box, select: Yes.