

- NOTES:
- 1 CONNECTION FOR SPEECH SYNTH-SERVICE TOOL
  - 2 NETWORK CONNECTION AVAILABLE FOR EXTERNAL SUITE CONNECTION
  - 3 NETWORK CONNECTION AVAILABLE AT FRONT OF DUPLEX ASSEMBLY FOR THE SERVICE LAPTOP
  - 4 FUTURE (MAGNET MONITOR)
  - 5 DEBUG PORT
  - 6 FUTURE (SPECIAL POINTING OR CONTROL INPUT DEVICE)
  - 7 FUTURE (CONTRAST INJECTION DEVICE)
  - 8 FUTURE (VTR CONTROL)
  - 9 FOR VIDEO CONFERENCING

REFER TO THE FOLLOWING FUNCTIONAL BLOCK DIAGRAM FOR ADDITIONAL INFORMATION:

- NOTE:
- 1) PATIENT HANDLING
  - 2) TPS/ISE

**SIGNA (8.X) OPERATOR WORKSPACE**  
(OPERATOR WORKSPACE CABINET/TABLE – INDIGO)

SHEET 1A OF 2

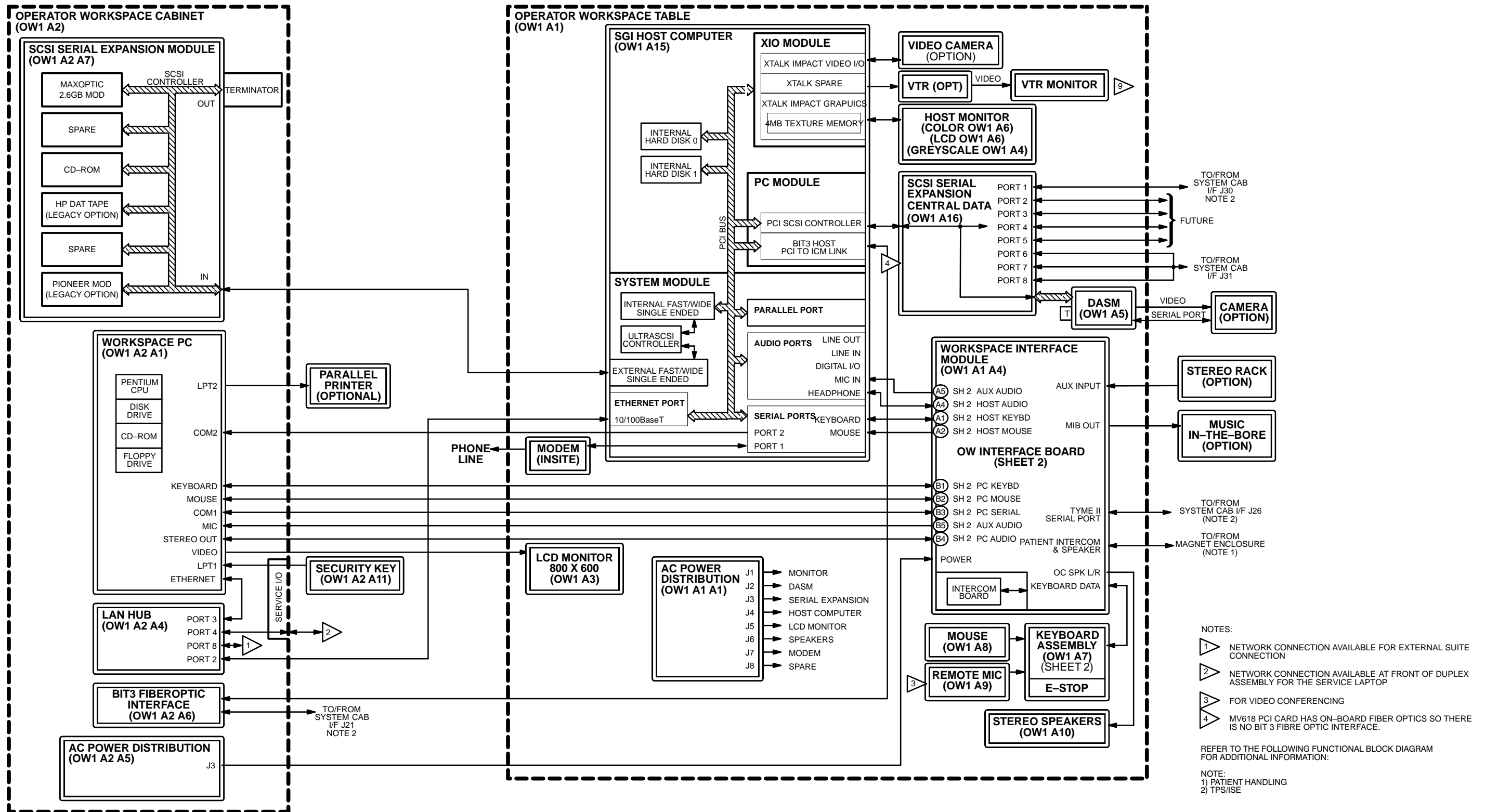

SIGNA (8.X) OPERATOR WORKSPACE (OPERATOR WORKSPACE CABINET/TABLE – OCTANE)

SHEET 1B OF 2

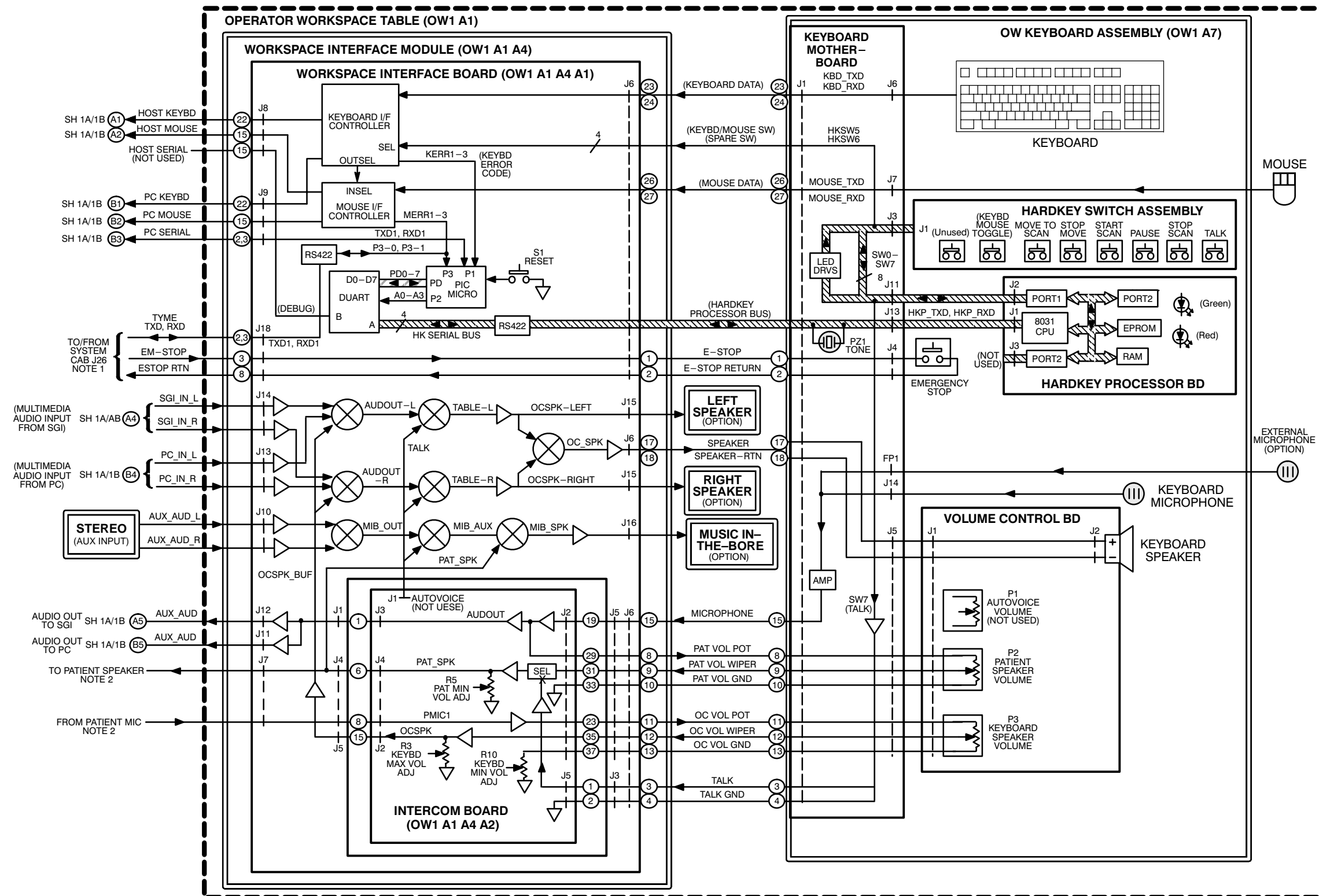

REFER TO THE FOLLOWING FUNCTIONAL BLOCK DIAGRAM FOR ADDITIONAL INFORMATION:

NOTE:  
1) PATIENT HANDLING  
2) TPS/ISE

SIGNA (8.X) OPERATOR WORKSPACE  
(OPERATOR WORKSPACE TABLE)

SHEET 2 OF 2