

Optima CT680 Series and Optima CT670 Installation Manual

(Book 1 of 2)



Book 1 of 2: Mechanical Installation

Pages 1 - 230

Effectivity

The information in this manual applies to the following Optima CT Systems:

- Optima CT680 Quantum
- Optima CT680 Expert
- Optima CT680 Professional
- Optima CT670

IMPORTANT PRECAUTIONS

LANGUAGE

<p>ПРЕДУПРЕЖДЕНИЕ (BG)</p>	<p>Това упътване за работа е налично само на английски език.</p> <ul style="list-style-type: none"> • Ако доставчикът на услугата на клиента изиска друг език, задължение на клиента е да осигури превод. • Не използвайте оборудването, преди да сте се консултирали и разбрали упътването за работа. • Неспазването на това предупреждение може да доведе до нараняване на доставчика на услугата, оператора или пациента в резултат на токов удар, механична или друга опасност.
<p>警告 (ZH-CN)</p>	<p>本维修手册仅提供英文版本。</p> <ul style="list-style-type: none"> • 如果维修服务提供商需要非英文版本，客户需自行提供翻译服务。 • 未详细阅读和完全理解本维修手册之前，不得进行维修。 • 忽略本警告可能对维修人员，操作员或患者造成触电、机械伤害或其他形式的伤害。
<p>警告 (ZH-HK)</p>	<p>本服務手冊僅提供英文版本。</p> <ul style="list-style-type: none"> • 倘若客戶的服務供應商需要英文以外之服務手冊，客戶有責任提供翻譯服務。 • 除非已參閱本服務手冊及明白其內容，否則切勿嘗試維修設備。 • 不遵從本警告或會令服務供應商、網絡供應商或病人受到觸電、機械性或其他危險。
<p>警告 (ZH-TW)</p>	<p>本維修手冊僅有英文版。</p> <ul style="list-style-type: none"> • 若客戶的維修廠商需要英文版以外的語言，應由客戶自行提供翻譯服務。 • 請勿試圖維修本設備，除非您已查閱並瞭解本維修手冊。 • 若未留意本警告，可能導致維修廠商、操作員或病患因觸電、機械或其他危險而受傷。
<p>UPOZORENJE (HR)</p>	<p>Ovaj servisni priručnik dostupan je na engleskom jeziku.</p> <ul style="list-style-type: none"> • Ako davatelj usluge klijenta treba neki drugi jezik, klijent je dužan osigurati prijevod. • Ne pokušavajte servisirati opremu ako niste u potpunosti pročitali i razumjeli ovaj servisni priručnik. • Zanimarite li ovo upozorenje, može doći do ozljede davatelja usluge, operatera ili pacijenta uslijed strujnog udara, mehaničkih ili drugih rizika.
<p>VÝSTRAHA (CS)</p>	<p>Tento provozní návod existuje pouze v anglickém jazyce.</p> <ul style="list-style-type: none"> • V případě, že externí služba zákazníkům potřebuje návod v jiném jazyce, je zajištění překladu do odpovídajícího jazyka úkolem zákazníka. • Nesnažte se o údržbu tohoto zařízení, aniž byste si přečetli tento provozní návod a pochopili jeho obsah. • V případě nedodržování této výstrahy může dojít k poranění pracovníka prodejního servisu, obslužného personálu nebo pacientů vlivem elektrického proudu, respektive vlivem mechanických či jiných rizik.

<p>ADVARSEL (DA)</p>	<p>Denne servicemanual findes kun på engelsk.</p> <ul style="list-style-type: none"> • Hvis en kundes tekniker har brug for et andet sprog end engelsk, er det kundens ansvar at sørge for oversættelse. • Forsøg ikke at servicere udstyret uden at læse og forstå denne servicemanual. • Manglende overholdelse af denne advarsel kan medføre skade på grund af elektrisk stød, mekanisk eller anden fare for teknikeren, operatøren eller patienten.
<p>WAARSCHUWING (NL)</p>	<p>Deze onderhoudshandleiding is enkel in het Engels verkrijgbaar.</p> <ul style="list-style-type: none"> • Als het onderhoudspersoneel een andere taal vereist, dan is de klant verantwoordelijk voor de vertaling ervan. • Probeer de apparatuur niet te onderhouden alvorens deze onderhoudshandleiding werd geraadpleegd en begrepen is. • Indien deze waarschuwing niet wordt opgevolgd, zou het onderhoudspersoneel, de operator of een patiënt gewond kunnen raken als gevolg van een elektrische schok, mechanische of andere gevaren.
<p>WARNING (EN)</p>	<p>This service manual is available in English only.</p> <ul style="list-style-type: none"> • If a customer's service provider requires a language other than English, it is the customer's responsibility to provide translation services. • Do not attempt to service the equipment unless this service manual has been consulted and is understood. • Failure to heed this warning may result in injury to the service provider, operator or patient from electric shock, mechanical or other hazards.
<p>HOIATUS (ET)</p>	<p>See teenindusjuhend on saadaval ainult inglise keeles.</p> <ul style="list-style-type: none"> • Kui klienditeeninduse osutaja nõuab juhendit inglise keelest erinevas keeles, vastutab klient tõlketeenuse osutamise eest. • Ärge üritage seadmeid teenindada enne eelnevalt käesoleva teenindusjuhendiga tutvumist ja sellest aru saamist. • Käesoleva hoiatuse eiramine võib põhjustada teenuseosutaja, operaatori või patsiendi vigastamist elektrilöögi, mehaanilise või muu ohu tagajärjel.
<p>VAROITUS (FI)</p>	<p>Tämä huolto-ohje on saatavilla vain englanniksi.</p> <ul style="list-style-type: none"> • Jos asiakkaan huoltohenkilöstö vaatii muuta kuin englanninkielistä materiaalia, tarvittavan käännöksen hankkiminen on asiakkaan vastuulla. • Älä yritä korjata laitteistoa ennen kuin olet varmasti lukenut ja ymmärtänyt tämän huolto-ohjeen. • Mikäli tätä varoitusta ei noudateta, seurauksena voi olla huoltohenkilöstön, laitteiston käyttäjän tai potilaan vahingoittuminen sähköiskun, mekaanisen vian tai muun vaaratilanteen vuoksi.
<p>ATTENTION (FR)</p>	<p>Ce manuel d'installation et de maintenance est disponible uniquement en anglais.</p> <ul style="list-style-type: none"> • Si le technicien d'un client a besoin de ce manuel dans une langue autre que l'anglais, il incombe au client de le faire traduire. • Ne pas tenter d'intervenir sur les équipements tant que ce manuel d'installation et de maintenance n'a pas été consulté et compris. • Le non-respect de cet avertissement peut entraîner chez le technicien, l'opérateur ou le patient des blessures dues à des dangers électriques, mécaniques ou autres.

<p>WARNUNG (DE)</p>	<p>Diese Serviceanleitung existiert nur in englischer Sprache.</p> <ul style="list-style-type: none"> Falls ein fremder Kundendienst eine andere Sprache benötigt, ist es Aufgabe des Kunden für eine entsprechende Übersetzung zu sorgen. Versuchen Sie nicht diese Anlage zu warten, ohne diese Serviceanleitung gelesen und verstanden zu haben. Wird diese Warnung nicht beachtet, so kann es zu Verletzungen des Kundendiensttechnikers, des Bedieners oder des Patienten durch Stromschläge, mechanische oder sonstige Gefahren kommen.
<p>ΠΡΟΕΙΔΟΠΟΙΗΣΗ (EL)</p>	<p>Το παρόν εγχειρίδιο σέρβις διατίθεται μόνο στα αγγλικά.</p> <ul style="list-style-type: none"> Εάν ο τεχνικός σέρβις ενός πελάτη απαιτεί το παρόν εγχειρίδιο σε γλώσσα εκτός των αγγλικών, αποτελεί ευθύνη του πελάτη να παρέχει τις υπηρεσίες μετάφρασης. Μην επιχειρήσετε την εκτέλεση εργασιών σέρβις στον εξοπλισμό αν δεν έχετε συμβουλευτεί και κατανοήσει το παρόν εγχειρίδιο σέρβις. Αν δεν προσέξετε την προειδοποίηση αυτή, ενδέχεται να προκληθεί τραυματισμός στον τεχνικό σέρβις, στο χειριστή ή στον ασθενή από ηλεκτροπληξία, μηχανικούς ή άλλους κινδύνους.
<p>FIGYELMEZTETÉS (HU)</p>	<p>Ezen karbantartási kézikönyv kizárólag angol nyelven érhető el.</p> <ul style="list-style-type: none"> Ha a vevő szolgáltatója angoltól eltérő nyelvre tart igényt, akkor a vevő felelőssége a fordítás elkészítése. Ne próbálja elkezdni használni a berendezést, amíg a karbantartási kézikönyvben leírtakat nem értelmezték. Ezen figyelmeztetés figyelmen kívül hagyása a szolgáltató, működtető vagy a beteg áramütés, mechanikai vagy egyéb veszélyhelyzet miatti sérülését eredményezheti.
<p>AÐVÖRUN (IS)</p>	<p>Þessi þjónustuhandbók er aðeins fáanleg á ensku.</p> <ul style="list-style-type: none"> Ef að þjónustuveitandi viðskiptamanns þarfnast annas tungumáls en ensku, er það skylda viðskiptamanns að skaffa tungumálþjónustu. Reynið ekki að afgreiða tækið nema að þessi þjónustuhandbók hefur verið skoðuð og skilin. Brot á sinna þessari aðvörun getur leitt til meiðsla á þjónustuveitanda, stjórnanda eða sjúklings frá raflosti, vélrænu eða öðrum áhættum.
<p>AVVERTENZA (IT)</p>	<p>Il presente manuale di manutenzione è disponibile soltanto in lingua inglese.</p> <ul style="list-style-type: none"> Se un addetto alla manutenzione richiede il manuale in una lingua diversa, il cliente è tenuto a provvedere direttamente alla traduzione. Procedere alla manutenzione dell'apparecchiatura solo dopo aver consultato il presente manuale ed averne compreso il contenuto. Il mancato rispetto della presente avvertenza potrebbe causare lesioni all'addetto alla manutenzione, all'operatore o ai pazienti provocate da scosse elettriche, urti meccanici o altri rischi.
<p>警告 (JA)</p>	<p>このサービスマニュアルには英語版しかありません。</p> <ul style="list-style-type: none"> サービスを担当される業者が英語以外の言語を要求される場合、翻訳作業はその業者の責任で行うものとさせていただきます。 このサービスマニュアルを熟読し理解せずに、装置のサービスを行わないでください。 この警告に従わない場合、サービスを担当される方、操作員あるいは患者さんが、感電や機械的又はその他の危険により負傷する可能性があります。

<p>경고 (KO)</p>	<p>본 서비스 매뉴얼은 영어로만 이용하실 수 있습니다.</p> <ul style="list-style-type: none"> • 고객의 서비스 제공자가 영어 이외의 언어를 요구할 경우, 번역 서비스를 제공하는 것은 고객의 책임입니다. • 본 서비스 매뉴얼을 참조하여 숙지하지 않은 이상 해당 장비를 수리하려고 시도하지 마십시오. • 본 경고 사항에 유의하지 않으면 전기 쇼크, 기계적 위험, 또는 기타 위험으로 인해 서비스 제공자, 사용자 또는 환자에게 부상을 입힐 수 있습니다.
<p>BRĪDINĀJUMS (LV)</p>	<p>Šī apkopes rokasgrāmata ir pieejama tikai angļu valodā.</p> <ul style="list-style-type: none"> • Ja klienta apkopes sniedzējam nepieciešama informācija citā valodā, klienta pienākums ir nodrošināt tulkojumu. • Neveiciet aprīkojuma apkopi bez apkopes rokasgrāmatas izlasīšanas un saprašanas. • Šī brīdinājuma neievērošanas rezultātā var rasties elektriskās strāvas trieciena, mehānisku vai citu faktoru izraisītu traumu risks apkopes sniedzējam, operatoram vai pacientam.
<p>ĮSPĖJIMAS (LT)</p>	<p>Šis eksploatavimo vadovas yra tik anglų kalba.</p> <ul style="list-style-type: none"> • Jei kliento paslaugų tiekėjas reikalauja vadovo kita kalba – ne anglų, suteikti vertimo paslaugas privalo klientas. • Nemėginkite atlikti įrangos techninės priežiūros, jei neperskaitėte ar nesupratote šio eksploatavimo vadovo. • Jei nepaisysite šio įspėjimo, galimi paslaugų tiekėjo, operatoriaus ar paciento sužalojimai dėl elektros šoko, mechaninių ar kitų pavojų.
<p>ADVARSEL (NO)</p>	<p>Denne servicehåndboken finnes bare på engelsk.</p> <ul style="list-style-type: none"> • Hvis kundens serviceleverandør har bruk for et annet språk, er det kundens ansvar å sørge for oversettelse. • Ikke forsøk å reparere utstyret uten at denne servicehåndboken er lest og forstått. • Manglende hensyn til denne advarselen kan føre til at serviceleverandøren, operatøren eller pasienten skades på grunn av elektrisk støt, mekaniske eller andre farer.
<p>OSTRZEŻENIE (PL)</p>	<p>Niniejszy podręcznik serwisowy dostępny jest jedynie w języku angielskim.</p> <ul style="list-style-type: none"> • Jeśli serwisant klienta wymaga języka innego niż angielski, zapewnienie usługi tłumaczenia jest obowiązkiem klienta. • Nie próbować serwisować urządzenia bez zapoznania się z niniejszym podręcznikiem serwisowym i zrozumienia go. • Niezastosowanie się do tego ostrzeżenia może doprowadzić do obrażeń serwisanta, operatora lub pacjenta w wyniku porażenia prądem elektrycznym, zagrożenia mechanicznego bądź innego.
<p>ATENÇÃO (PT-BR)</p>	<p>Este manual de assistência técnica encontra-se disponível unicamente em inglês.</p> <ul style="list-style-type: none"> • Se outro serviço de assistência técnica solicitar a tradução deste manual, caberá ao cliente fornecer os serviços de tradução. • Não tente reparar o equipamento sem ter consultado e compreendido este manual de assistência técnica. • A não observância deste aviso pode ocasionar ferimentos no técnico, operador ou paciente decorrentes de choques elétricos, mecânicos ou outros.

<p>ATENÇÃO (PT-PT)</p>	<p>Este manual de assistência técnica só se encontra disponível em inglês.</p> <ul style="list-style-type: none"> • Se qualquer outro serviço de assistência técnica solicitar este manual noutra língua, é da responsabilidade do cliente fornecer os serviços de tradução. • Não tente reparar o equipamento sem ter consultado e compreendido este manual de assistência técnica. • O não cumprimento deste aviso pode colocar em perigo a segurança do técnico, do operador ou do paciente devido a choques eléctricos, mecânicos ou outros.
<p>ATENȚIE (RO)</p>	<p>Acest manual de service este disponibil doar în limba engleză.</p> <ul style="list-style-type: none"> • Dacă un furnizor de servicii pentru clienți necesită o altă limbă decât cea engleză, este de datoria clientului să furnizeze o traducere. • Nu încercați să reparați echipamentul decât ulterior consultării și înțelegerii acestui manual de service. • Ignorarea acestui avertisment ar putea duce la rănirea deparatorului, operatorului sau pacientului în urma pericolelor de electrocutare, mecanice sau de altă natură.
<p>ОСТОРОЖНО! (RU)</p>	<p>Данное руководство по техническому обслуживанию представлено только на английском языке.</p> <ul style="list-style-type: none"> • Если сервисному персоналу клиента необходимо руководство не на английском, а на каком-то другом языке, клиенту следует самостоятельно обеспечить перевод. • Перед техническим обслуживанием оборудования обязательно обратитесь к данному руководству и поймите изложенные в нем сведения. • Несоблюдение требований данного предупреждения может привести к тому, что специалист по техобслуживанию, оператор или пациент получит удар электрическим током, механическую травму или другое повреждение.
<p>UPOZORENJE (SR)</p>	<p>Ovo servisno uputstvo je dostupno samo na engleskom jeziku.</p> <ul style="list-style-type: none"> • Ako klijentov serviser zahteva neki drugi jezik, klijent je dužan da obezbedi prevodilačke usluge. • Ne pokušavajte da opravite uređaj ako niste pročitali i razumeli ovo servisno uputstvo. • Ne pokušavajte da opravite uređaj ako niste pročitali i razumeli ovo servisno uputstvo.
<p>UPOZORNENIE (SK)</p>	<p>Tento návod na obsluhu je k dispozícii len v angličtine.</p> <ul style="list-style-type: none"> • Ak zákazníkovi poskytovateľ služieb vyžaduje iný jazyk ako angličtinu, poskytnutie prekladateľských služieb je zodpovednosťou zákazníka. • Nepokúšajte sa o obsluhu zariadenia, kým si neprečítate návod na obsluhu a neporozumiete mu. • Zanedbanie tohto upozornenia môže spôsobiť zranenie poskytovateľa služieb, obsluhujúcej osoby alebo pacienta elektrickým prúdom, mechanické alebo iné ohrozenie.

<p>ATENCIÓN (ES)</p>	<p>Este manual de servicio sólo existe en inglés.</p> <ul style="list-style-type: none"> • Si el encargado de mantenimiento de un cliente necesita un idioma que no sea el inglés, el cliente deberá encargarse de la traducción del manual. • No se deberá dar servicio técnico al equipo, sin haber consultado y comprendido este manual de servicio. • La no observancia del presente aviso puede dar lugar a que el proveedor de servicios, el operador o el paciente sufran lesiones provocadas por causas eléctricas, mecánicas o de otra naturaleza.
<p>VARNING (SV)</p>	<p>Den här servicehandboken finns bara tillgänglig på engelska.</p> <ul style="list-style-type: none"> • Om en kunds servicetekniker har behov av ett annat språk än engelska, ansvarar kunden för att tillhandahålla översättningstjänster. • Försök inte utföra service på utrustningen om du inte har läst och förstår den här servicehandboken. • Om du inte tar hänsyn till den här varningen kan det resultera i skador på serviceteknikern, operatören eller patienten till följd av elektriska stötar, mekaniska faror eller andra faror.
<p>OPOZORILO (SL)</p>	<p>Ta servisni priročnik je na voljo samo v angleškem jeziku.</p> <ul style="list-style-type: none"> • Če ponudnik storitve stranke potrebuje priročnik v drugem jeziku, mora stranka zagotoviti prevod. • Ne poskušajte servisirati opreme, če tega priročnika niste v celoti prebrali in razumeli. • Če tega opozorila ne upoštevate, se lahko zaradi električnega udara, mehanskih ali drugih nevarnosti poškoduje ponudnik storitev, operater ali bolnik.
<p>DİKKAT (TR)</p>	<p>Bu servis kılavuzunun sadece ingilizcesi mevcuttur.</p> <ul style="list-style-type: none"> • Eğer müşteri teknisyeni bu kılavuzu ingilizce dışında bir başka lisandan talep ederse, bunu tercüme ettirmek müşteriye düşer. • Servis kılavuzunu okuyup anlamadan ekipmanlara müdahale etmeyiniz. • Bu uyarıya uyulmaması, elektrik, mekanik veya diğer tehlikelerden dolayı teknisyen, operatör veya hastanın yaralanmasına yol açabilir.

DAMAGE IN TRANSPORTATION

All packages should be closely examined at time of delivery. If damage is apparent, have notation "Damage in Shipment" written on all copies of the freight or express bill before delivery is accepted or "signed for" by a General Electric representative or a hospital receiving agent. Whether noted or concealed, damage MUST be reported to the carrier immediately upon discovery, or in any event, within 14 days after receipt, and the contents and containers held for inspection by the carrier. A transportation company will not pay a claim for damage if an inspection is not requested within this 14-day period.

To file a report:

- Call 1-800-548-3366 and use option 6.
- Fill out the GIQ workflow for any items missing, damaged, OBF/FOI for in process installs:
http://supportcentral.ge.com/ProcessMaps/form_new_request.asp?prod_id=268679&form_id=573167&node_id=1916016&map_id=&reference_id=&reference_type
- Contact your local service coordinator for more information on this process.

CERTIFIED ELECTRICAL CONTRACTOR STATEMENT

All electrical Installations that are preliminary to positioning of the equipment at the site prepared for the equipment shall be performed by licensed electrical contractors. In addition, electrical feeds into the Power Distribution Unit shall be performed by licensed electrical contractors. Other connections between pieces of electrical equipment, calibrations and testing shall be performed by qualified GE Medical personnel. The products involved (and the accompanying electrical installations) are highly sophisticated, and special engineering competence is required. In performing all electrical work on these products, GE will use its own specially trained field engineers. All of GE's electrical work on these products will comply with the requirements of the applicable electrical codes.

The purchaser of GE equipment shall only utilize qualified personnel (i.e., GE's field engineers, personnel of third-party service companies with equivalent training, or licensed electricians) to perform electrical servicing on the equipment.

IMPORTANT...X-RAY PROTECTION

X-ray equipment, if not properly used, may cause injury. Accordingly, the instructions herein contained should be thoroughly read and understood by everyone who will use the equipment before you attempt to place this equipment in operation. The General Electric Company, GE Healthcare Group, will be glad to assist and cooperate in placing this equipment in use.

Although this apparatus incorporates a high degree of protection against x-radiation other than the useful beam, no practical design of equipment can provide complete protection. Nor can any practical design compel the operator to take adequate precautions to prevent the possibility of any persons carelessly exposing themselves or others to radiation.

It is important that anyone having anything to do with x-radiation be properly trained and fully acquainted with the recommendations of the National Council on Radiation Protection and Measurements as published in NCRP Reports available from NCRP Publications, 7910 Woodmont Avenue, Room 1016, Bethesda, Maryland 20814, and of the International Commission on Radiation Protection, and take adequate steps to protect against injury.

The equipment is sold with the understanding that the General Electric Company, GE Healthcare Group, its agents, and representatives have no responsibility for injury or damage which may result from improper use of the equipment.

Various protective materials and devices are available. It is urged that such materials or devices be used.

IMPORTANT...RADIOACTIVE MATERIAL HANDLING

Only employees formally trained in radioactive materials handling and this equipment are authorized by the GE Healthcare Radiation Safety Officer to use radioactive materials to service this equipment.

GE Healthcare is required to notify the applicable U.S. state agency PRIOR to any source service event involving pin source handling. See NUC/PET radioactive material guides for specific instruction or contact your EHS Specialist.

A radiation survey must be performed when a pin source has been removed and replaced. See Radiation Survey Form Instructions or contact your EHS Specialist.

Rev 2 (July 21, 2005)

LITHIUM BATTERY CAUTIONARY STATEMENTS**CAUTION**

Risk of Explosion.

Danger of explosion if battery is incorrectly replaced.

Replace only with the same or equivalent type recommended by the manufacturer. Discard used batteries according to the manufacturer's instructions.

ATTENTION

Danger d'Explosion

Il y a danger d'explosion s'il y a remplacement incorrect de la batterie.

Remplacer uniquement avec une batterie du même type ou d'un type recommandé par le constructeur. Mettre au rebut les batteries usagées conformément aux instructions du fabricant.

OMISSIONS & ERRORS

Customers, please contact your GE Sales or Service representatives. GE personnel, please use the GE Healthcare PQR Process to report all omissions, errors, and defects in this publication.

Revision History

Rev	Date	Reason for change
9	Jan 09, 2020	Chapter 6, Section 1.6.4: Added Exam Split information in the option table.
8	Sep 05, 2018	Chapter 6, Section 1.4.2: Updated Figure 6-8 Network Settings Screen and Table 6-4
7	July 17, 2018	Chapter 1, Section 17.0: Add OpenOC unpack and install information Chapter 1, Section 17.0: Add Figure 1-85 Seismic OpenOC Console Mounting Hole Locations Chapter 2, Section 4.0: Add section 4.0 for OpenOC connections Chapter 3, Section 4.0: Add section 4.0 for LB Tube Label Installation Appendix D, Section 2.0: Add Open OC for Remote Monitor
6	Sep 04, 2017	Add the Optima CT670 product name
5	May 05, 2017	Chapter 2, Section 3.3.2: Added HP LCD connection information Chapter 2, Section 3.4: Added Figure 2-12 for z840 rear panel connection Chapter 8, Section 3.0: Added Figure 8-8 for z840 rear panel connection
4	May 20, 2016	Chapter 2, Section 3.1: Added keyboard overlay installation information Update Figure 2-5 and Table 2-5 for GSCB connection Section 3.2: Added PMT-22 information
3	Sep 06, 2015	Chapter 1, Section 5.4: Updated Figure 1-5 Chapter 1, Section 11: Added information of 5487992-2 Anchor
2	April 09, 2014	Chapter 2: Updated Table 2-3 system interconnect cables information Chapter 4: Updated Figure 4-5 Gantry Base Cover Installed Chapter 8: Added Section 4.0 and Section 5.0 option installation
1	Dec 20, 2013	Initial release for KL64 Saturn MV

Table of Contents: Book 1

Preface

Publication Conventions 21

Section 1.0

Safety & Hazard Information 21

1.1 Text and Character Representation..... 21
 1.2 Graphical Representation 22

Section 2.0

Publication Conventions 23

2.1 General Paragraph and Character Styles..... 23
 2.2 Page Layout..... 23
 2.3 Computer Screen Output/Input Character Styles 24
 2.4 Buttons, Switches and Keyboard Inputs (Hard & Soft Keys)..... 24

Chapter 1

Position Subsystems 25

Section 1.0 Installer/FE Notices 25

1.1 General Safety Guidelines..... 25
 1.2 Shipping, Warehouse and Transportation Warning..... 25
 1.3 International Shipments 25
 1.4 On Site Warning 25
 1.5 Service Actions 25

Section 2.0

Introduction 26

2.1 Overview..... 26
 2.2 Pre-Installation Template..... 26
 2.3 Required Common Tools and Supplies 27

Section 3.0 Delivery Procedure..... 30

3.1 System Transportation - Temperature Extremes..... 30
 3.2 Stored Systems 30
 3.3 Construction Site Storage..... 30
 3.4 Construction Site Installations 30
 3.4.1 Construction Site with Completed Radiology Area 31
 3.4.2 Full Construction Site with Limited Delivery Access 31
 3.4.3 Construction Site Unpacking 31
 3.5 Working with the Mover 32
 3.5.1 Delivery Dolly Options: 32
 3.5.2 Equipment Delivery Route 32
 3.5.3 Floor Protection 32
 3.5.4 Removing Gantry Dollies and Covers..... 32
 3.6 Damage In Transportation 32
 3.7 A1 Breaker..... 33
 3.7.1 Installation Conditions..... 34

Section 4.0 Layout the Floor Template 35

4.1	Time & Personnel.....	35
4.2	Tools and Test Equipment	35
4.3	Safety	35
4.4	Floor Preparation	35
	4.4.1 Preparation.....	35
	4.4.2 Flooring	35
4.5	Room Preparation	36
4.6	Procedure.....	36
	Section 5.0 Install the Gantry	40
5.1	Time and Personnel	40
5.2	Tools and Test Equipment	40
5.3	Gantry Preparation.....	40
	5.3.1 Access Greater than 28 in.....	40
	5.3.2 Access Less than 28 in.	40
5.4	Procedure.....	41
	Section 6.0 Level the Gantry.....	44
6.1	Time and Personnel	44
6.2	Tools and Test Equipment	44
6.3	Procedure.....	44
	Section 7.0 Gantry Bearing Gap Inspection.....	47
7.1	Time and Personnel	47
7.2	Tools and Test Equipment	47
7.3	Preparation: Damage Indicators	47
7.4	Procedure.....	48
7.5	Finalization	49
	7.5.1 Mechanical Installers.....	49
	7.5.2 FE Service Action, if Required	49
	7.5.3 FE Inspection Completion	50
	Section 8.0 Install Gantry Alignment Laser and Bracket.....	51
8.1	Time and Personnel	51
8.2	Tools and Test Equipment	51
8.3	Procedure.....	51
	Section 9.0 Table Installation (GT1700V).....	55
9.1	Time and Personnel	55
9.2	Tools and Test Equipment	55
9.3	Procedures.....	55
	9.3.1 Draw Table Reference Lines.....	55
	9.3.2 Table Prep and Set-up	56
	9.3.3 Table Cover Removal	58
	9.3.4 Removing the Accessory Rail Strip	59
	9.3.5 Install the Table Cradle Laser Alignment Plates	59
	9.3.6 Level and Center the Table to the Gantry	60
	9.3.6.1 Conditions	60
	9.3.6.2 Specifications	60
	9.3.6.3 Procedure	60
	9.3.7 Tighten the Lock Rings	63
	Section 10.0 Table Installation (Lite Table)	64
10.1	Time and Personnel.....	64

10.2	Tools and Test Equipment.....	64
10.3	Procedures	64
10.3.1	Draw Table Reference Lines	64
10.3.2	Cradle Center Procedure.....	66
10.3.3	Install the Table Cradle Laser Alignment Plates	67
10.3.4	Level and Center the Table to the Gantry.....	68
10.3.4.1	Conditions.....	68
10.3.4.2	Specifications	68
10.3.4.3	Procedure	69
Section 11.0 Drill the Anchor Holes.....		70
11.1	Notes to Mechanical Installers.....	70
11.2	Requirements	70
11.3	Drilling Procedure (For Gantry and GT1700V Table)	71
11.4	Drilling Procedure (For Lite Table).....	74
11.5	Gantry & Table (GT1700V) Alternate Anchor Holes.....	76
11.6	Lite Table Redundant Anchor Holes.....	77
11.7	Install the Anchors (For Gantry and GT1700V Table)	78
11.8	Install the Anchors (For Lite Table).....	80
11.9	Alignment Recheck.....	81
11.10	Removing Table Shipping Dollies.....	82
11.10.1	Time and Personnel.....	82
11.10.2	Tools and Test Equipment.....	82
11.10.3	Preparation	82
11.10.4	Procedure	82
Section 12.0 Rear Entry Cable Box.....		84
12.1	Rear Entry with Surface Floor Duct.....	85
Section 13.0 Install Table Footswitch Assembly (GT1700V).....		86
13.1	Time and Personnel.....	86
13.2	Tools and Test Equipment.....	86
13.3	Procedure	86
Section 14.0 Install Table Footswitch Assembly (Lite Table)		90
14.1	Time and Personnel.....	90
14.2	Tools and Test Equipment.....	90
14.3	Procedure	90
Section 15.0 Remove Gantry Tilt Bracket		92
15.1	Time and Personnel.....	92
15.2	Tools and Test Equipment.....	92
15.3	Procedure	92
Section 16.0 Position the Power Distribution Unit.....		93
16.1	Time and Personnel.....	93
16.2	Tools and Test Equipment.....	93
16.3	Procedure	93
Section 17.0 Install Operator Console.....		97
17.1	Unpack OpenOC Console	97
17.2	Unpack NIO Console	98
17.2.1	Remove the HostPC support Bracket.....	99
17.2.2	Footer Adjustment	99

17.3	Install Operation Table	100
17.3.1	Install Aurora SWS table	100
17.4	Peripherals Placement	100
Section 18.0 Seismic Mounting		101
18.1	Time and Personnel	101
18.2	Procedures	101
18.2.1	Console	101
18.2.2	Power Distribution Unit	102

Chapter 2

Power, Ground & Interconnect Cables 105

Section 1.0 Introduction		105
1.1	Cable Storage	105
1.2	System Component Identification	106
1.3	Cable Color Identifiers	106
Section 2.0 System Interconnect Diagram		108
Section 3.0 NIO Console Connections		109
3.1	GSCB, Keyboard & Mouse Installation	109
3.2	Connecting the Media Tower (5270510-20/-21/-22)	112
3.3	Connecting the LCD Monitor	113
3.3.1	Connect Scan Monitor and Image Monitor for EIZO LCD:	113
3.3.2	Connect Scan Monitor and Image Monitor for HP LCD:	114
3.3.3	LCD Video Monitor Setup	115
3.4	Host Computer Connections	116
3.5	Switch Hub Connections	119
3.6	AC Box Connections	120
3.7	Cable Arrangement	121
Section 4.0 OpenOC Console Connections		122
4.1	GSCB, Keyboard, Trackball & Mouse Installation	122
4.2	Connecting the Media Tower (5270510-22)	125
4.3	Connecting the LCD Monitor	126
4.3.1	Connecting the Scan Monitor and Image Monitor for z840 Host Computer	126
4.3.2	LCD Video Monitor Setup	127
4.4	OpenOC Interconnect	128
4.5	Host Computer Connections	129
4.6	Network Switch Hub Connections	131
4.7	AC Box Connections	132
4.8	Cable Arrangement	133
Section 5.0 Install Options		134
5.1	Install USB Barcode Reader	134
5.2	Install Optional Remote Monitor	134
5.3	Install Accessory I/F Hardware (IPC) Option	134
5.4	Install Respiratory Gating Option	134
5.5	Install Injector Option	134
5.6	Install Cardiac Gating IVY Monitor and Stand Option	134
5.7	Customer Accessories - Head Holders and Extender	135
5.8	UPS Installation	135

- 5.9 Flat Tabletop used with Respiratory Gating..... 135
- 5.10 SmartStep Installation..... 135
- Section 6.0 Gantry Cable Connections 136**
- 6.1 Gantry Cable Connections..... 136
- 6.2 Cardiac Monitor Setup..... 139
- 6.3 Respiratory Monitor Setup (Version 1.7) 141
- Section 7.0 Table Connections (GT1700V) 142**
- Section 8.0 Table Connections (Lite Table) 143**
- Section 9.0**
- PDU Cable Connections & Configuration 144**
- 9.1 Introduction to NGPDU 144
 - 9.1.1 Panel - 380 - 480VAC Mains “TS1” Input Power Connection..... 145
 - 9.1.2 Panel - Circuit Breakers..... 145
 - 9.1.3 HVDC Connection 146
 - 9.1.4 440V Connection 147
 - 9.1.5 Gantry & Console Power Connections 147
 - 9.1.6 PDU Control Cable 148
 - 9.1.7 System Ground Connection..... 148
 - 9.1.8 Warning Light & Door Interlock Connections..... 149
 - 9.1.8.1 Warning Light Configuration & Connection 149
 - 9.1.8.2 Door Interlock Connections 150
- Section 10.0 System Ground Connections 151**

Chapter 3
System Continuity & Ground Checks..... 153

- Section 1.0 System Continuity (Mechanical Contractor)..... 153**
- 1.1 Time and Personnel..... 153
- 1.2 Tools and Test Equipment..... 153
- 1.3 Procedure 153
- Section 2.0 Site Ground Continuity Check 157**
- Section 3.0 Shim Installation..... 158**
- 3.1 Time and Personnel..... 158
- 3.2 Tools and Test Equipment..... 158
- 3.3 Preparation 158
- 3.4 Procedure 159
- 3.5 Finalization..... 160
- Section 4.0 LB Tube Label Installation..... 161**
- 4.1 Procedure 161
 - 4.1.1 Label of PDU and Main Power Switch Panel..... 161

Chapter 4
System Covers: Installation & Alignment 163

- Section 1.0 Process Overview 163**
- 1.1 Gantry Front Cover Installation..... 164

1.2	Gantry Rear Cover Installation	164
1.3	Gantry Bore Cover Installation	164
1.4	Gantry Top Covers	165
1.4.1	Installation	165
1.5	Gantry Side Covers	165
1.5.1	Installation	165
1.6	Gantry Strap Installation	165
1.7	Scan Windows	167
1.7.1	Installation	167
1.8	Install Gantry Base Covers	168
1.8.1	Tools Required	168
1.8.2	Procedure	168
1.8.3	Footswitch Covers Installation (GT1700V)	169
Section 2.0 Install Console Covers		170
2.1	Time and Personnel	170
2.2	Tools and Test Equipment	170
2.3	Procedures	170
2.3.1	Console Side Covers	170
2.3.2	Console Top Cover	171
2.3.3	Console Front Cover	172
Section 3.0 Table Cover Installation (GT1700V)		173
3.1	Side Covers	173
3.2	Install Panels	173
3.2.1	Top Panel #1	173
3.2.2	Bottom Panel #1	173
3.2.3	Top Panel #2	174
3.2.4	Bottom Panel #2	174
3.3	Re-install Side Panel	174
3.4	Table Side Covers Install	174
3.5	Table Side Covers Removal	174
Section 4.0 Table Covers Installation (Lite Table)		175
4.1	Table Base Cover	175
4.2	Flapper Installation	175
4.3	Skirt Cover installation	176
4.4	Bottom cover installation	177
Section 5.0 Install All Option Covers		178
Section 6.0 Electrical Power On & Ground Checks		178
6.1	Introduction and Flowchart	179
6.2	Electrical Power On & Ground Checks Process Overview	179
6.3	Required Tools	179
6.4	Initial PDU Configuration	179
6.4.1	Circuit Breakers	179
6.4.2	Relay Board	179
6.4.3	Power Switches	180
6.4.4	Hardware and Connection Check	180
6.4.5	Covers	180
6.5	Suite Emergency Off Checks	181
6.6	Line Transformer Settings	181

- 6.6.1 Requirements 181
- 6.6.2 Line Input Conditions 181
- 6.7 System Power-Up 182
- 6.8 Install PDU Covers 185
 - 6.8.1 Time and Personnel 185
 - 6.8.2 Tools and Test Equipment 185
 - 6.8.3 Procedure 185
 - 6.8.4 Emergency Stop Check 185
- Section 7.0 Mechanical Installation Completion Checklist 187**

Appendix A

Gantry Cover Removal and Dolly Setup 189

- Section 1.0 Gantry Cover Removal 189**
 - 1.1 Time & Personnel 189
 - 1.2 Tools and Test Equipment 189
 - 1.3 Procedures 189
 - 1.3.1 Gantry Scan Window 189
 - 1.3.2 Side Cover Removal 190
 - 1.3.3 Top Cover Removal 191
 - 1.3.4 Gantry Front Cover 192
 - 1.3.5 Bore Cover Removal 203
 - 1.3.6 Gantry Rear Cover 206

Appendix B

Pictorial Representation of Required Tools 209

Appendix C

Operating Table Installation and Adjustment 213

- Section 1.0**
- Smart Workspace Table Assembly and Adjustment 213**

Appendix D

Remote Monitor Option Console Wiring 217

- Section 1.0**
- NIO Console Remote Monitor Wiring Overview 217**
 - 1.1 Wiring Installation 217
 - 1.1.1 Power Down System 217
 - 1.1.2 Install 4-Way Splitter 218
- Section 2.0**
- Open OC Remote Monitor Wiring Overview 224**
 - 2.1 Remote Monitor Wiring Overview 224
 - 2.2 Wiring Installation 225
 - 2.2.1 Power Down System 225
 - 2.2.2 Install 4-Way Splitter 225

Preface

Publication Conventions

Please become familiar with the conventions used within this publication before proceeding.

Section 1.0 Safety & Hazard Information

1.1 Text and Character Representation

Within this publication, different paragraph and character styles have been used to indicate potential hazards. Paragraph prefixes, such as hazard, caution, danger and warning, are used to identify important safety information. Text (Hazard) styles are applied to the paragraph contents that is applicable to each specific safety statement. Words describe the type of potential hazard that may be encountered and are placed immediately before the paragraph it modifies. Safety information will normally include:

- Type of potential hazard
- Nature of potential injury
- Causative condition
- How to avoid or correct the causative condition

EXAMPLES OF HAZARD STATEMENTS USED

A few examples are provided below. They include paragraph prefixes and modified text styles.



CAUTION
Pinch Points
Loss of Data
Sharp Objects

Caution is used when a hazard exists that can or could cause minor injury to self or others if instructions are ignored. They include for example:

- Loss of critical patient data
- Crush or pinch points
- Sharp objects



DANGER
EXCESSIVE
VOLTAGE
CRUSH
POINT

DANGER IS USED WHEN A HAZARD EXISTS THAT WILL CAUSE SEVERE PERSONAL INJURY OR DEATH IF INSTRUCTIONS ARE IGNORED. THEY CAN INCLUDE:


- ELECTROCUTION
- CRUSHING
- RADIATION



WARNING
ROTATING
EQUIPMENT
BARE WIRES

WARNING IS USED WHEN A HAZARD EXISTS WHICH COULD OR CAN CAUSE SERIOUS PERSONAL INJURY OR DEATH IF INSTRUCTIONS ARE IGNORED. THEY CAN INCLUDE:

- Potential for shock
- Exposed wires
- Failure to Tag and lockout system power could allow for un-command motion.


 **NOTICE**
Equipment Damage Possible

Notice is used when a hazard is present that can cause property damage but has absolutely no personal injury risk. They can include:

- Disk drive will crash
- Internal mechanical damage, such as to the x-ray tube
- Coasting the rotor through resonance.

It's important that the reader not ignore hazard statements in this document.

1.2 Graphical Representation

Important information will always be preceded by the exclamation point  contained within a triangle, as seen throughout this chapter. In addition to text, several different graphical icons (symbols) may be used to make you aware of specific types of hazards that could possibly cause harm.

ELECTRICAL



LASER



MECHANICAL



HEAT



RADIATION



PINCH



Some others make you aware of specific procedures that should be followed.

AVOID STATIC ELECTRICITY



TAG AND LOCK OUT



WEAR EYE PROTECTION



Section 2.0 Publication Conventions

2.1 General Paragraph and Character Styles

Prefixes are used to highlight important non-safety related information. Paragraph prefixes (such as Purpose, Example, Comment and Note) are used to identify important but non-safety related information. Text styles are also applied to text within each paragraph modified by the specific prefix.

EXAMPLES OF PREFIXES USED FOR GENERAL INFORMATION

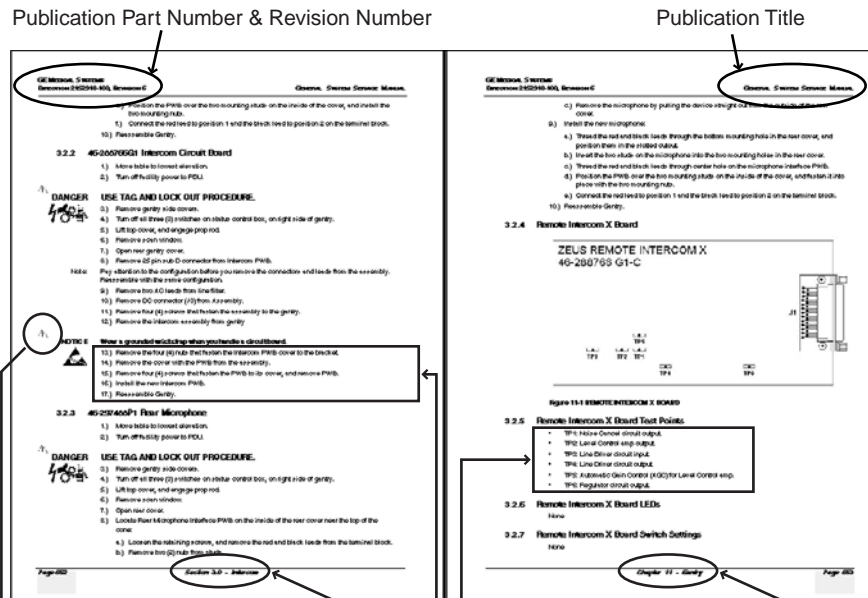
Purpose: Introduces and provides meaning as to the information contained within the chapter, section or subsection, such as used at the beginning this chapter for example.

Note: Conveys information that should be considered important to the reader.

Example: Used to make the reader aware that the paragraph(s) that follow are examples of information possibly stated previously.

Comment: Represents "additional" information that may or may not be relevant.

2.2 Page Layout



The current section and its title are always shown in the footer of the left (even) page.

An exclamation point in a triangle is used to indicate important information to the user.

Paragraphs preceded by Alphanumeric (e.g. numbers) characters is information that must be followed in a specific order.

The current chapter and its title are always shown in the footer of the right (odd) page.

Paragraphs preceded by symbols is information that has no specific order.

Headers and footers in this publication are designed to allow you to quickly identify your location. The document's part number and revision number appears in every header on every page. Odd numbered page footers indicate the current chapter, its title, and current page number. Even page footers show the current section and its title, as well current page number.

2.3 Computer Screen Output/Input Character Styles

Within this publication different character styles are used to indicate computer input and output text. Character (input, output, and variable) styles are used and applied to the text within a paragraph so as to indicate directions. Computer screen output and input is also formatted using mono (fixed width) spaced fonts.

Example: This paragraph denotes computer screen fixed output. It's output is fixed from the sense that it does not vary from application to application. It's the most commonly used style used to indicate filenames, paths, and text.
Fixed Output

Example: *This paragraph denotes computer screen output that is variable. Its output varies from application to application. Variable output is sometimes found placed between greater than and lesser than operators. For example: <variable_ouput>*
Variable Output

Example: **This paragraph denotes fixed input. It's typed input that will not vary from application to application. Fixed text the user is required to supply as input.**
Fixed Input

Example: ***This paragraph denotes computer input that can vary from application to application. Variable text the user is required to supply as input. Variable input sometimes is placed between greater than and lesser than operators. For example: <variable_input>. In these cases, the (<>) operators are dropped prior to input. Exceptions are noted in the text.***
Variable Input

2.4 Buttons, Switches and Keyboard Inputs (Hard & Soft Keys)

Different character styles are used to indicate actions requiring the reader to press either a hard or soft button, switch, or key. Physical hardware, such as buttons and switches, are called hard keys because they are hard wired or mechanical in nature. A keyboard or on/off switch would be a hard key. Software or computer generated buttons are called soft keys because they are software generated. Software driven menu buttons are an example of such keys. Soft and hard keys are represented differently in this publication.

Example: A power switch **ON/OFF** or a keyboard key like **ENTER** is indicated by applying a character style that uses both over and under-lined bold text that is bold. This is a hard key.
Hard Keys

Example: Whereas the computer **MENU** button that you would click with your mouse or touch with your hand uses over and under-lined regular text. This is a soft key.
Soft Keys

Chapter 1

Position Subsystems



NOTICE

- Record data collected from procedures in this chapter into Form 4879 when directed.
- Only use the installation manual that arrives with your system. Any other revisions of this manual may not exactly match your system.

Section 1.0 Installer/FE Notices

1.1 General Safety Guidelines

- 1.) Follow all safety precautions, warnings and instructions in this manual.
- 2.) Read and obey the warning and instructions on equipment labels or tags.
- 3.) Allow only qualified personnel to install, maintain and service this equipment.
- 4.) While the system is designed to meet all safety requirements applicable to medical equipment, qualified operators must understand the potential safety hazards, and take steps to minimize the risk at all times.
- 5.) Never modify the system in whole or part without prior written approval by GE Healthcare.
- 6.) Do not change, add or remove any system accessory without prior written approval of the vendors local service manager.
- 7.) Never leave the system in an unsafe condition. Notify the customer that the system is not to be used until a problem is resolved.
- 8.) Read and follow the precautions described in this manual.

1.2 Shipping, Warehouse and Transportation Warning

This gantry should be moved using the shipping dollies only. Do not lift or move it using a lift truck under the gantry frame.

1.3 International Shipments

- Use dollies to remove the gantry from the shipping skid and to transport the gantry to the customer's site.
- If lifting is required, instructions are in the *Pre-Installation Manual* for this system.

1.4 On Site Warning

This system requires a gantry bearing gap inspection *before* electrical calibration is started.

1.5 Service Actions

If the bearing inspection fails the FE opens a dispatch and does not continue with the electrical calibration procedures.

Section 2.0 Introduction

This chapter describes how to mount, position, and level the CT Scanner subsystems.

Note: Before you start the installation, make sure the site preparation complies with conditions and instructions found in the *Pre-installation Manual* for this system. Failure to comply results in excessive installation delay and potential increased, unrecoverable installation costs. This product is designed to meet specific mechanical installation standards that should be reviewed prior to installing this system.

2.1 Overview

Note: Installation paperwork is required for all installations.

Procedures in this chapter provide detailed instructions to position, level, and anchor the gantry and table securely for operation. The system uses adjustable leveling pads to support the gantry and table. The gantry has four (4) primary leveling pads located on the gantry base. The table has four (4) pads used for leveling it.

The process you follow is:

- 1.) Use the room-layout template to determine the general position of the gantry and table.
- 2.) Move the gantry into position.
- 3.) Level gantry.
- 4.) Use the laser tool to position the table relative to the gantry.
- 5.) Level the table to the gantry, and anchor the system.
- 6.) Complete the mechanical installation section of GE Form e4879.

Note: Use the template to position the system. Use the gantry and table to locate and drill the anchor holes. Drill the anchor holes with the system in place. Refer to [Section Section 5.0, on page 40](#) for an example of this procedure. This CT system installation procedure requires the items listed in [Section Section 2.3, on page 27](#).

2.2 Pre-Installation Template

Always use the room layout template (two pieces), during installation. The gantry and table are not properly aligned if existing holes are used. The template shows the location of the gantry and table anchor holes.

The applicable template is shipped with the system. It is located on the middle shelf on the Lean Installation Cart. You can also order it via the web GEMS BUY, from Coakley-Tech.

Room Layout Template:

- **For the system with GT1700V: P/N 5341997-2**
- **For the system with Lite Table: P/N 5193991**

2.3 Required Common Tools and Supplies

The following tools and supplies should be included in the standard CT installation tool kit. The tools listed represent the minimum tools required for installing this CT scanner.

Wrenches

- Standard and metric combination wrench sets
- Standard and metric hex key (Allen wrench) sets
- ½ in. and 3/8 in. (9.5mm), drive torque wrench: 0-100 N-m (0-100 ft.-lb.) Must be calibrated yearly.

Sockets and Extensions

- 3/8 in. drive metric and standard socket set
- 1 in, 1-1/8 in, 1-¼ in, 1-½ in, 1-5/8 in sockets
- ½ in. drive ratchet wrenches
- ¾ in. deep well socket
- Metric hex bit set ¼ in. or 3/8 in. drive, including 10 mm and 14 mm hex bit
- 3/8 in. drive universal joint
- 21mm socket (optional)

Screw Drivers

- Torque Screwdriver
- Phillips screwdriver set (small, medium, and large)
- Straight blade screwdriver set (small, medium, and large)
- Pozi-drive 0 (S)
- Pozi-drive #1
- Hex bit set with: Flat blade bit, Plus blade bit, Hex bits, and Star bits.

Drill Bits

- Complete set of standard (U.S.) drill bits
- Metric tap set (Optional)
- ½ in. masonry bit, min. 10 in. long USA; 12 in. optional (Bit must not be metric.)
- 4" (100mm) hole saw with 1/8" (5mm) masonry bit (to remove flooring)

Power Tools

- 3/8 in. or ½ in. drill, cordless or electric
- Reciprocating saw (Sawzall or equivalent) and assorted blades
- Hammer Drill & Bit (8 in. min, 12 in. max)
- Sears shop vacuum or equivalent, with HEPA or drywall dust filter
- 25 ft. extension power cords

Electrical Tools

- DVM capable of reading 0.5 ohms or less
- Continuity Tester
- FE Electronic Monitor Static Kit or equivalent static mat kit with ground wrist strap (P/N 2220482)
- Dale 600 or 601 Leakage meter or equivalent
- Temperature/humidity tool: Oregon Scientific Wireless Weather Station Model BAR608HGA or equivalent

Hand Tools

- Ball-peen hammer (1 lb. or 2 lb.)
- Tongue & groove pliers (large)
- Diagonal cutting pliers, large (to cut 1/0 ground)
- Diagonal cutting pliers, small and large
- Large pry bar 460 mm . 600 mm (18 in. - 24 in.)

Recommended Levels

- Johnson Magnetic Level, model 7500M -- 225 mm (9 in.)
- Johnson Professional Box Beam Level, model 9624 -- 600 mm (24 in.)
- Digital level with accuracy of $\pm 0.1^\circ$ -- 225 mm (9 in.)
- Johnson Professional Box Beam Level -- 1225 mm (48 in.) (Optional)

Personal Safety Equipment

- Safety shoes*
 - Safety glasses*
 - Hand Protection (Leather is required when performing duct work.)
 - Knee pads or kneeling pad
 - Face Shield
 - LOTO kit -- MUST have tags and appropriate lock(s)
 - Hearing protection
 - 2 m (6 ft.) or 4 m (8 ft.) step ladders or equivalent
- * Required items

System Cleaners

Purchase Locally:

- Alcohol
- 10% Bleach
- *Scrubbing Bubbles* bathroom cleaner or equivalent
- Sani-cloth HB
- Incidin Plus
- TriGrene

Other

Purchase locally (available at office supply stores): a China marker or wax marking pencil or equivalent, any color that is visible on the floor where the system is being installed. Permanent markers are often used if the lines will be covered by the product.

GE Tools

- System Alignment Kit (p/n 5148193 or p/n 5272090)
(This tool may not be available via the tool pool in some areas.)

Section 3.0 Delivery Procedure

3.1 System Transportation - Temperature Extremes

When transporting the CT system, ensure that the system is not exposed to temperatures or humidity outside the following specifications.

Temperature: -40° to +158° F (-40° to +70° C)

Humidity: 10% to 100%

NOTICE **Component Freezing occurs if CT system is exposed to temperatures below 0° F (-18° C) for a period longer than two days.**

Allow a minimum of 12 hours for the CT system to adjust to ambient room temperature prior to installation.

Inspect for visible condensation and allow all moisture to evaporate before starting the installation.

3.2 Stored Systems

If your system was stored for more than three months:

- Complete a visual inspection, looking for damage due to improper storage.
- Check for the latest software revisions, options, and component changes.
- Contact the OLC for support.
- Movers are required to move the equipment to the scan room.

3.3 Construction Site Storage

When storing the CT system at a construction site, be sure to adhere to the following storage requirements:

- Construction site packaging must be ordered and the system shipped packaged for storage.
- Do not damage or puncture the shipping crate.
- Do not remove packaging until the completion of all construction at the site and the removal of all dust created by the construction.
- Maintain a storage temperature within the range of 10° to 32° C (50° to 90° F).
- Maintain a relative humidity (non-condensing) between 20% and 70%.

3.4 Construction Site Installations

A construction installation describes installations at sites without an occupancy permit, or ongoing construction. In general, construction sites fail to meet the required specifications for system delivery, and GE Healthcare does not recommend such installations, as they can result in delays, increased costs, and possible damage to the system. When construction-site delivery proves unavoidable, the installation falls into one of two categories:

- Full construction site with completed radiology area.
- Full construction site with limited delivery access.

Review these categories to determine which most closely matches the condition of the planned installation site.

3.4.1 Construction Site with Completed Radiology Area

This type of site consists of a finished, dust-free, occupancy-ready radiology suite at a site with ongoing construction in other areas, but with no remaining construction in or around the scan suite area. At the time of delivery such sites feature:

- Dust control measures deployed in the radiology suite area.
- Scan suite access limited to a single entrance.
- Radiology suite sealed off from the remaining construction area.
- Operational HVAC, with a positive air pressure within the radiology suite.

In addition, the radiology suite at such a site REMAINS in a dust-free, occupancy-ready state after delivery and throughout the remaining construction phase.

For more details, refer to the *Pre-Installation Manual*.

3.4.2 Full Construction Site with Limited Delivery Access

This type of site allows delivery during ongoing construction of the radiology suite area.

Construction site packaging must be ordered and the system is delivered packed for construction site storage. Packaging cannot be added during the delivery.

At Full Construction sites, delivery occurs prior to site completion, but the product remains stored until the completion of a finished, dust-free, occupancy-ready radiology suite area. This system is delivered in sealed packages with dollies. Delivery to the storage area requires a lift truck or riggers. Installation work can begin **only** when the site reaches the completed, dust-free, occupancy-ready radiology suite requirement.

3.4.3 Construction Site Unpacking

If room is not completed, follow escalation process. Pre-installation escalation is the process used to consult CT Engineering, the Design Center, or EHS to resolve pre-installation issues related to siting concerns and requirements.

A typical construction site package consists of 8-12 packages. Each package is plastic-wrapped in dust-free packaging. Each package must be vacuumed to remove construction dust prior to moving components into the CT scan room. This process can add approximately two hours to your installation time.

Typical components are:

- Gantry
- Table
- Console
- PDU
- UPS
- Lean Cover Cart
- Lean Install Cart
- Chair
- Service Cabinet

3.5 Working with the Mover

- System is shipped lean-packed in North America.
- Ensure that the installation lean cart is the first item moved into the room.

3.5.1 Delivery Dolly Options:

- Gantry Mini Dolly - ordered from UMI at <http://www.umi-dollyshop.com>

Follow the instructions provided by your Project Manager of Installation regarding working with equipment movers. Help direct movers as to where to place equipment and which items are needed first.

Movers should move all equipment into the customer's room. Door removal and other site changes to move equipment should be done only as directed by the Project Manager of Installation.

For component sizes and weights, refer to the *Pre-installation Manual* for this system.

Note: Do not place equipment in its final location at this time. Templates must be laid first.

Note: If you have to remove the gantry covers in order to move the gantry into the room, please read the notice statement on [Appendix A Gantry Cover Removal and Dolly Setup, on page 189](#) before removing the gantry covers.

3.5.2 Equipment Delivery Route

Prior to equipment delivery, review the delivery route with the movers. Refer to the Project Manager of Installation for any additional delivery instructions.

3.5.3 Floor Protection

Movers should use floor protection. Most equipment movers can provide floor protection during the equipment delivery. Installers should provide floor protection for the room.

3.5.4 Removing Gantry Dollies and Covers

- Gantry components cannot be removed to reduce the dimensions.
- Zero clearance dollies are available from UMI at <http://www.umi-dollyshop.com>
- Please read the notice statement on [page 192](#) before removing the gantry covers.

3.6 Damage In Transportation

Check for damage to property that may have occurred at the site during delivery, such as damage to floors, door frames or walls. If damage is found, notify the Project Manager of Installation.

All packages should be closely examined at time of delivery. If damage is apparent, have notation "Damage in Shipment" written on all copies of the freight or express bill before delivery is accepted or "signed for" by a General Electric representative or a hospital receiving agent. Whether noted or concealed, damage shall be reported to the carrier immediately upon discovery, or in any event, within 14 days after receipt, and the contents and containers held for inspection by the carrier. A transportation company will not pay a claim for damage if an inspection is not requested within this 14-day period.

To file a report:

- Call 1-800-548-3366 and use option 8.
- Fill out a report on <http://egems.med.ge.com/edq/home.jsp>
- Contact the local service coordinator for more information on this process.

Rev. June 13, 2006

3.7 A1 Breaker



NOTICE

- All sites must have a main disconnect with Lockout/Tagout capability.
- Non GE-supplied breakers must have/provide under-voltage protection. For more information, refer to the *Pre-Installation Manual* for this system.
- A LICENSED ELECTRICIAN shall install and make connections inside the main disconnect.

Lock-out and tag-out the A1 breaker now.

A1 Breaker	UPS
North America (440V or 460-480V) E4502AB	Optional Partial UPS Kit B7999ZA
Europe and Asia (380-400V or 420V): E4502AC	

Table 1-1



Figure 1-1 Sample A1 Breaker

Lock-out and tag-out the A1 breaker now.

A1 Breaker	UPS
North America (440V or 460-480V) E4502BB	Optional Partial UPS Kit B7999ZA
Europe and Asia (380-400V or 420V): E4502BC	

Table 1-2



Figure 1-2 Sample A1 Breaker

3.7.1 Installation Conditions

- 1.) A Final Site Print is required. Contact your PMI for a final site print.
- 2.) The room size must match the print.
 Measure the room size. If it does not match the stated size, and is smaller, then check all clearances. **Service clearances MUST be met to continue.**
- 3.) A customer Anchoring Plan is required if there is anything other than a 101.6 mm (4 in.) (minimum) concrete floor. GE employees shall only install the anchors supplied with this system.
- 4.) Complete this section on the GE Form e4879.
- 5.) Do not start the installation process if the site is under construction:
 - In the room
 - In the scan area
 - In addition, the radiology suite at such a site will REMAIN in a dust-free, occupancy-ready state after delivery and throughout the remaining construction phase.

Section 4.0 Layout the Floor Template

4.1 Time & Personnel

Required Persons	Preliminary Reqs	Procedure	Finalization
2 (FE or mechanical supplier)			

4.2 Tools and Test Equipment

- Standard Install Tool Kit
- Install Support Kit
- GE Site Print
- Floor Template for your system
- Chalk line
- China marker or wax marking pencil, or equivalent
- Masking Tape, or equivalent
- PPE (hand protection, foot protection, face shield, eye protection, personal dosimeter)
- Alignment Kit Laser

4.3 Safety

CAUTION Potential for Injury.

The gantry presents a variety of mechanical and electrical hazards.



4.4 Floor Preparation

4.4.1 Preparation

The PMI notifies the installation team if any requirements are not met. It is the purchaser's (buyer) responsibility to provide an approved support structure and an approved method of mounting. General Electric is not responsible for any failure of the support structure or method of anchoring.

4.4.2 Flooring

The system has a total floor load of approximately 3000 kg (6600 lbs). A concentrated load of about 2500 kg (5500 lbs), including patient (227 kg (500 lbs)) is found in the table-gantry assembly. For more information, refer to the Pre-installation Manual for this system.

Do not place the scanner on any resilient flooring. Resilient tile or carpeting may slowly yield over a period of time and disturb the alignment of the table to the gantry. Refer to the floor template to determine locations where resilient flooring material should be removed.

Limitations include:

- No part of the floor surface within the table, gantry, or the two interface areas between table and gantry should be higher than the support areas for the table and gantry.

- The floor structure must withstand the occupied weight of table and gantry, as well as the individual contact area loading of these components.
- The method and placement of anchors or through bolts must not reduce the structural strength of the floor. In some circumstances, the final floor may not be installed. Refer to Chapter 8.0 in the *Pre-Installation Manual* for this system.

If you have to remove the gantry covers in order to move the gantry into the room, refer to the cover removal procedure. Please read the notice statement on [Appendix A Gantry Cover Removal and Dolly Setup](#), on page 189 before removing the gantry covers.

4.5 Room Preparation

- Use the GE print developed for your site to establish the room layout. Make sure all the operating and service clearances shown on the print are observed. Record this information on the GE Form e4879.
- Clean the area. The mounting surface must be free of any material that may interfere with the positioning and leveling of the system.
- Measure and determine ISO using the GE Site print. Using a marker, mark ISO on the floor. Use a chalk line to connect the table center line marks on the floor. This is the line on the print that runs down the center of the table through the gantry. Use this as a reference when positioning the table.

4.6 Procedure

- 1.) Lay out the two (2) pieces of the floor template. Start with the table template, then place the gantry template over the top of the table template. Align them per the GE print.
- 2.) Tape the templates together, making sure that the table and gantry center lines are matched. Then tape the template to the floor.
- 3.) Recheck the position of the gantry in the room per the GE print. If everything matches the GE print, continue. If not, realign the templates to match the print.
- 4.) Make sure there are no potential clearance issues. If there are floor obstructions, such as conduits or old anchors, be sure to cut them flush to the floor to prevent the gantry from resting on them. Also, be sure there is at least 102 mm (4 in.) of clearance between any existing floor penetration and the new gantry position.

Note: There must be clear space without obstructions in order to:

- Change major components, with access to the gantry tube-change (RH) side (See [Figure 1-3](#)).
- Allow space for front and rear cover removal

Note: See Service Clearance Section found in the *Pre-Installation Manual*.



Figure 1-3 Gantry Tube Change Cart

- 5.) Prior to removing this template, check floor levelness, as shown in [Figure 1-4](#).
- 6.) Position the laser from the install kit on the template behind the table base and turn it on to project a horizontal beam across the floor template area.
- 7.) Measure the distance from the floor to the laser line at each bolt hole location on the template and record the measurements. Use the measurements to verify the floor is within specification. The floor must meet the minimum levelness specification: 6 mm (1/4 in.) over 3.5 m (10 ft.) between the table and gantry.

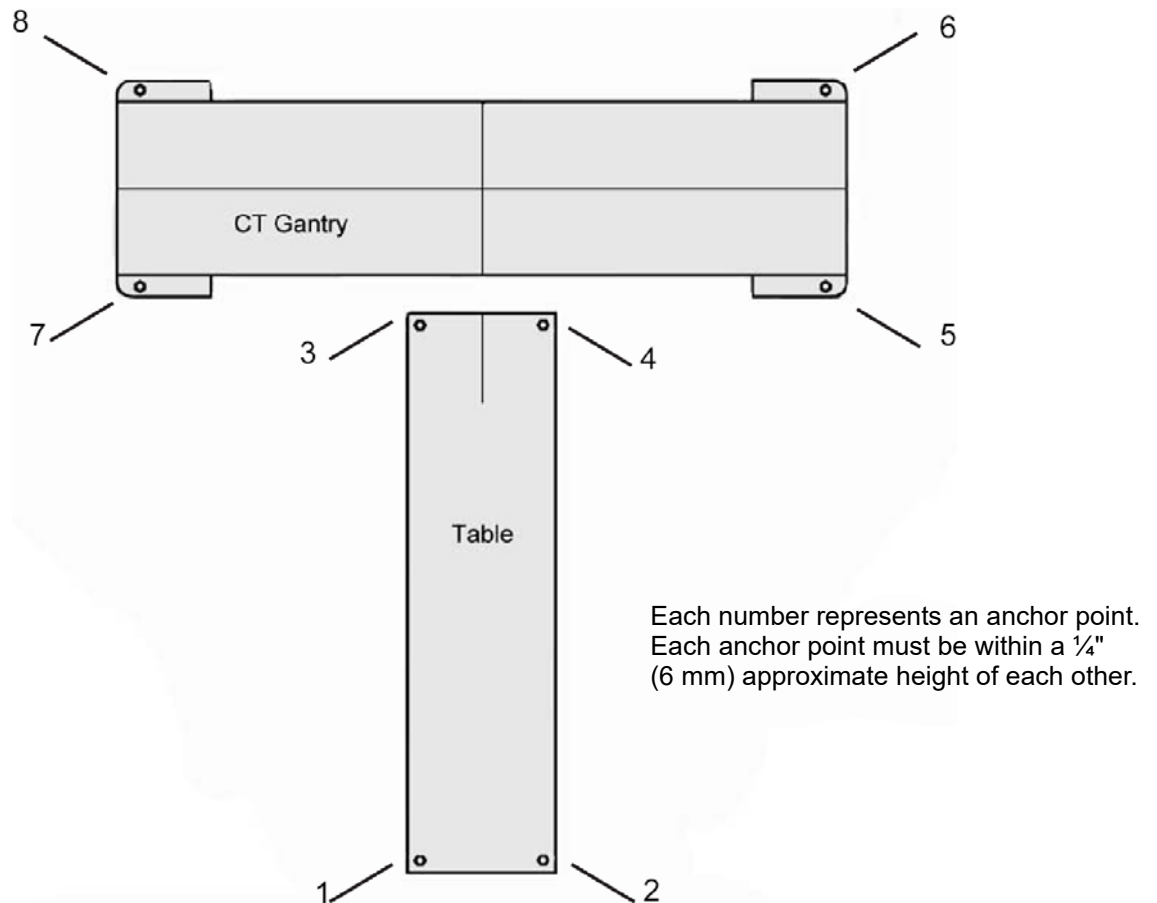


Figure 1-4 Check Floor Level

NOTICE Positioning requires cutting eight (8) holes in the floor covering.

Before you drill or cut any flooring, make sure that you have discussed this issue with the customer, and that the appropriate hospital personnel have approved the location of the table/gantry.

Any repositioning must meet all regulatory requirements to be completed.

- Check that the floor meets the levelness specification. Follow the escalation procedure if the floor does not meet the floor specification.
 - If the floor is not level, the system does not meet the table ISO specification. The distance from the table cradle to the floor cannot be greater than 1005 mm (40 in.).
- 8.) Check with the customer for approval of the gantry/table placement.

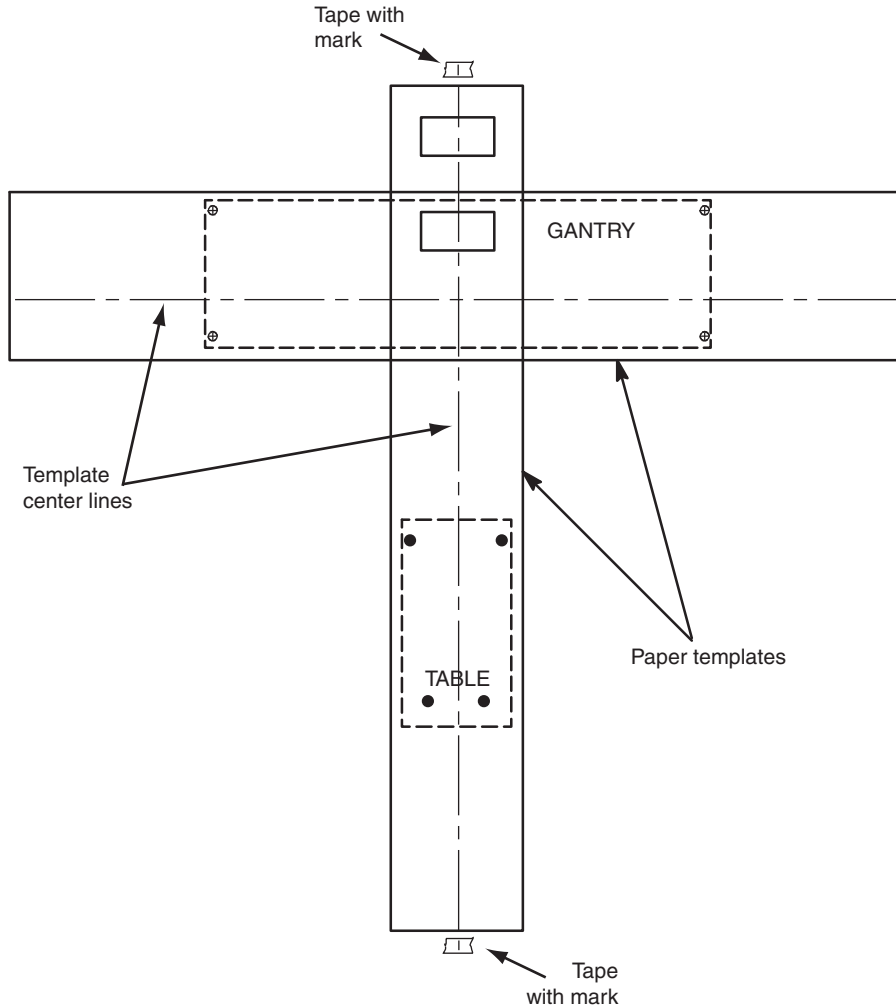


Figure 1-5 Center Line with Marks

- 9.) Use a center punch to mark hole centers for each of the eight (8) leveling pad/anchor locations per [Figure 1-5](#). Before moving on to the next step, see [Step 11](#) and its note for an alternative method.

CAUTION Potential for personal injury.



Use appropriate safety procedures when drilling the floor holes, especially if there is lead under the floor.

Appropriate PPE is required when working with hazardous materials.

- 10.) Remove the floor template.

11.) Cut tiles (or other resilient flooring) around all holes punched in the template for the gantry and table.

Note: A fast way to remove flooring is to use a 4 in. hole saw with a 1/4 in. masonry bit to cut through the flooring at each leveler pad location.

12.) Some sites require sealing of the floor penetrations after the flooring is removed. If this site does, use RTV or other sealant to seal the floor covering as necessary.

NOTICE **All documentation in this manual is based on mounting the table/gantry on a 102 mm (4 in.) - 110mm (4-1/3 in.) concrete floor.**

13.) Snap a chalk line using the marks that were made on the tape at the ends of the table template.

Section 5.0 Install the Gantry

5.1 Time and Personnel

Required Persons	Preliminary Reqs	Procedure	Finalization
2 (FE or mechanical supplier)			

5.2 Tools and Test Equipment

- Standard Install Tool Kit
- Install Support Kit
- GE Site Print
- Installation Manual
- Gantry Adjuster Tool, P/N 2107863
- Spanner Wrench, P/N 2110003
- PPE (hand protection, foot protection, face shield, eye protection, personal dosimeter)

5.3 Gantry Preparation

Note: Locate and install any required floor protection now.

5.3.1 Access Greater than 28 in.

Remove all the transportation packaging from the gantry, except for the dollies.

5.3.2 Access Less than 28 in.

Measure from the wall or object protruding from the wall to the gantry side cover. The gantry left side cover must be installed for this measurement. When finished, the gantry cannot be closer than 14 in. to the wall or object protruding from the wall.

- 1.) Remove all the transportation packaging from the gantry, except for the dollies.
- 2.) Remove the blue dolly from the left side of the gantry and install the limited access dolly so that the gantry can be positioned closer to the left side wall.
 - a.) Remove the three (3) M14 hex bolts that secure the gantry to the dolly.
 - b.) Replace the removed dolly with the shipped black gantry-positioning dolly, and reinstall the three (3) M14 hex bolts.
 - c.) Raise the gantry so that it is once again off of the floor.

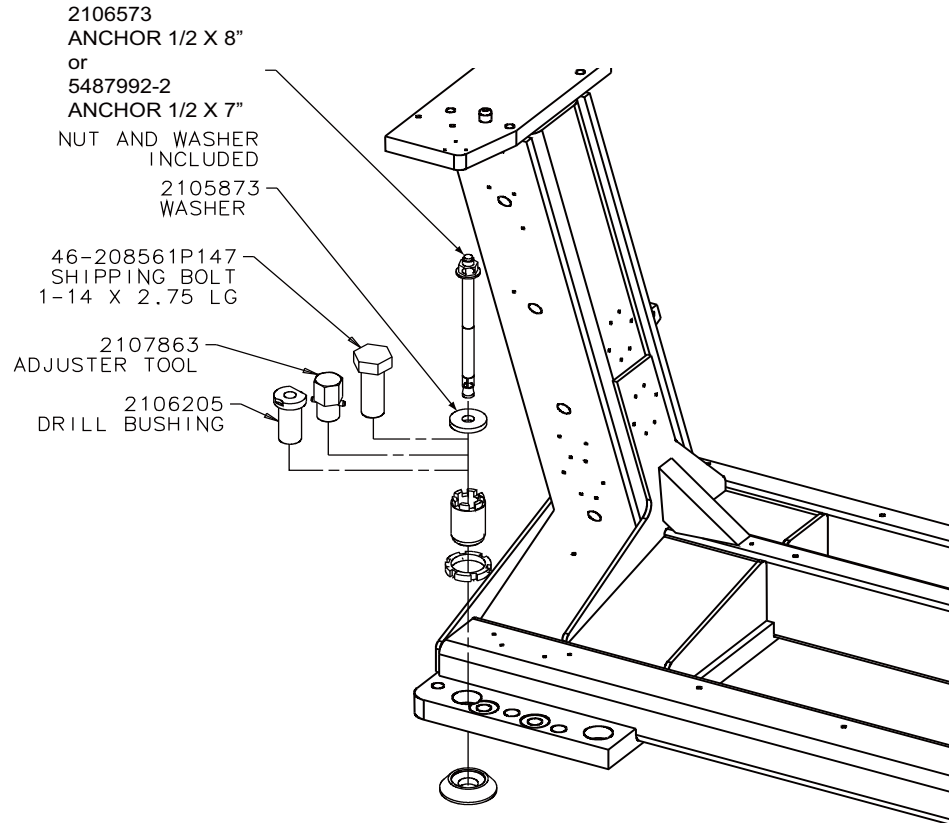


The gantry can now be moved up to 14 in. from the wall, measured from the wall or object protruding from the wall to the gantry side cover. Only use the supplied, limited-access dolly for this procedure.

Note: If this procedure cannot be completed, follow the site escalation procedure established for your area.

5.4 Procedure

- 1.) Position the gantry over the floor cutouts appropriately.
 - a.) Locate the four (4) leveling pads, and position each of them beneath its associated adjuster.
 - b.) Use the dollies to evenly lower the gantry, until it is just off of the floor (approximately 3/8" or 17.0 mm). Use a 1/2" ratchet to raise and lower the dollies.
 - c.) Carefully rotate the gantry into the correct position over the template.



Note: Adjusters are used at each anchor location. Anchor hole ID is 1" (2.5 cm). Void between adjuster and anchor must be filled according to local building codes for seismic application.

Figure 1-6 Gantry Base Installation Hardware

- 2.) Remove the paper templates from the floor and discard properly.
- 3.) Loosen the locking rings and shipping bolts so you can fine-tune the leveling pads to compensate for slight variations in the floor surface.
- 4.) Position the gantry so that the adjusters are centered over their respective holes scribed earlier into the floor.

IMPORTANT:

Make certain to route the gantry power cord under the two rear gantry rails, before removing the gantry shipping dollies.

- 5.) Using a 1/2" ratchet, gently lower the gantry until it rests on the floor, over the marked areas.

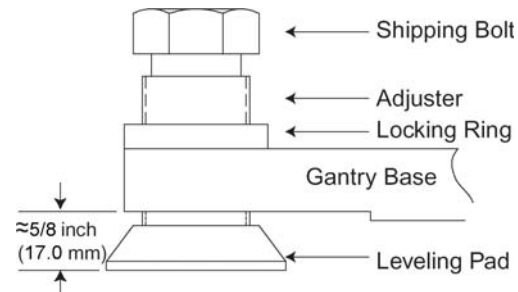


Figure 1-7 Gantry and Table Base Leveling Pads (Starting Positions)

NOTICE



Gantry dollies weigh approximately 250 lbs each. Exercise caution when removing dollies so as to not damage the floor covering.

- 6.) Using a 14mm hex socket, remove the dollies from the gantry by removing the three dolly bolts found at both ends of the gantry (Figure 1-8).

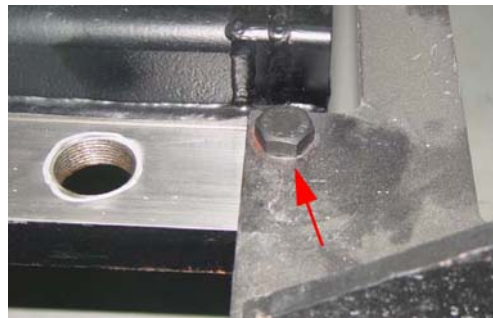


Figure 1-8 Gantry Dolly Bolts

- 7.) Remove the dolly plates on both sides of the gantry. Retain the dolly plates in the service cabinet at the hospital.



Figure 1-9 Dolly Plate

8.) Remove the four (4) gantry shipping bolts, using a 1½" socket.

46-208561P147
SHIPPING BOLT
1-14 X 2.75 LG

Note: Bolt requires
a 1-½" socket

Note:
Leave this locking ring
off, so that the alignment
bar will fit into the
alignment hole.

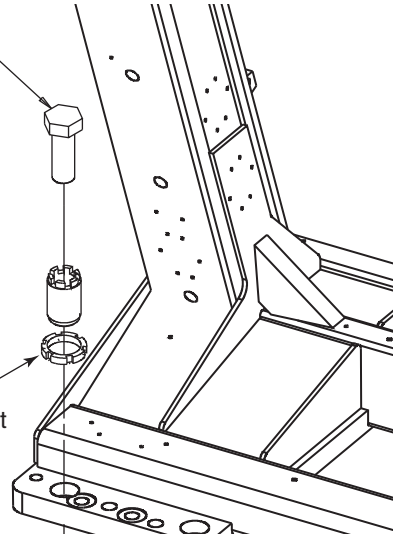


Figure 1-10 Gantry Shipping Bolts

Section 6.0 Level the Gantry

6.1 Time and Personnel

Required Persons	Preliminary Reqs	Procedure	Finalization
2 (FE or mechanical supplier)			

6.2 Tools and Test Equipment

- Standard Install Tool Kit
- Install Support Kit
- GE Site Print
- Gantry Adjuster Tool, P/N 2107863
- Spanner Wrench, P/N 2110003
- PPE

6.3 Procedure

The gantry uses 2 bubble levels that are permanently mounted to machined surfaces on the stationary base to tell when it is level.

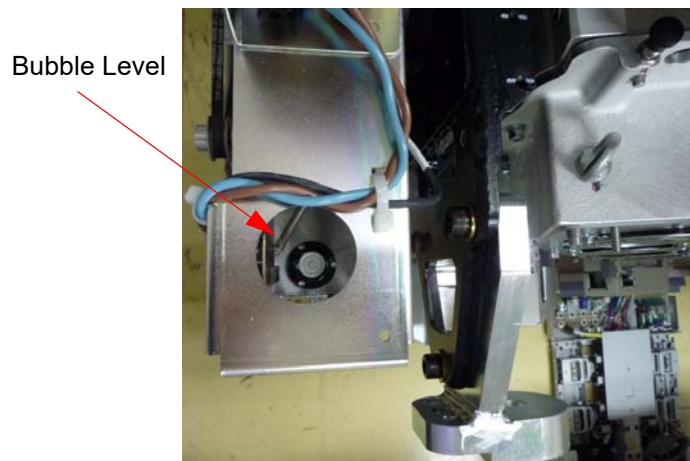


Figure 1-11 Gantry Bubble Level

Bubble levels are located on both ends of the gantry stationary base. They're located on the stationary base near a point where the rotating structure pivots mount to the base structure. (See [Figure 1-11](#).) The gantry is properly leveled when the bubble is centered. (See [Figure 1-13](#), on page 46).

- 1.) Loosen all adjuster lock rings (use a spanner wrench or large channel lock pliers).
- 2.) Systematically turn each of the gantry's adjusters (locations 1, 2, 3 and 4 in [Figure 1-12](#)) until both bubble levels are centered left to right and front to back.
 - Begin by turning each adjuster no more than 1 turn at a time.
 - Use the adjuster tool, 1-1/8" socket, and the 1/2" drive ratchet to turn each adjuster. (Refer to [Figure 1-6](#), on page 41.)

Systematic Procedure for Leveling gantry follows:

- a.) Level the left side from front to back by turning adjusters #1 and #2.
- b.) Level the right side from front to back by turning adjusters #3 and #4.
- c.) Level the side (right or left) that is higher with respect to the other side. Turn both adjusters on a side equally until that side is level. The side should now also be level.

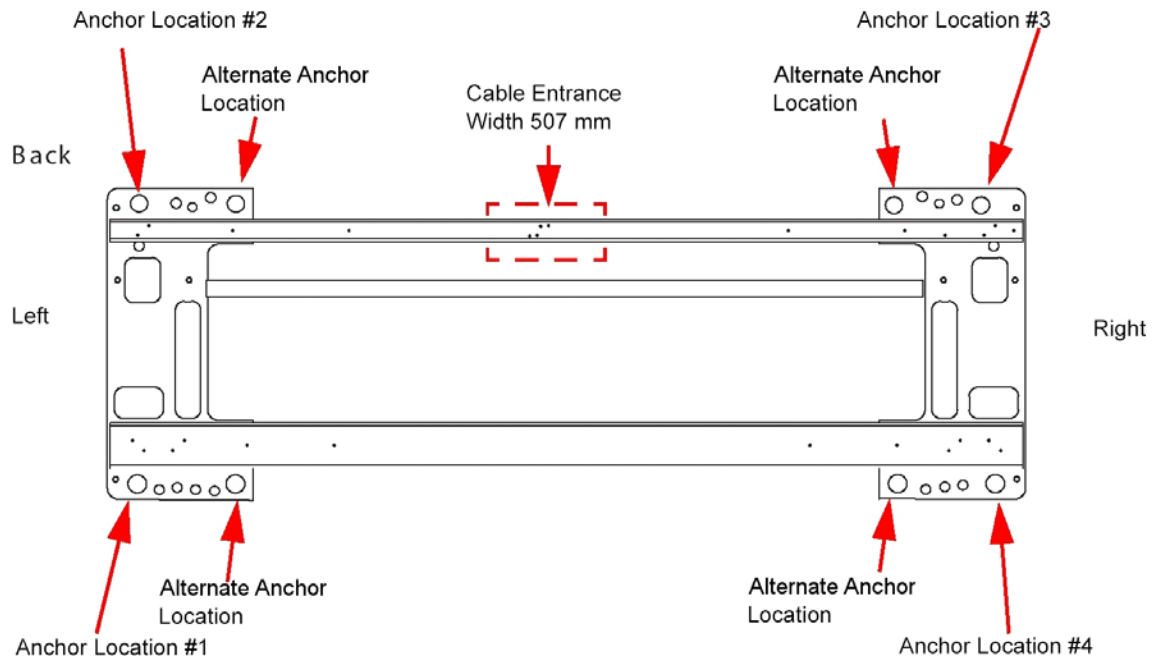


Figure 1-12 Gantry Base "Adjuster" Locations - Top View

- 3.) When the bubble levels are centered ([Figure 1-13](#)), each of the four (4) leveling pads should be carrying a portion of the gantry weight. Distribution of the gantry weight prevents the base frame from rocking during normal operation. **DO NOT leave any adjuster un-loaded or floating.**

Correct level is 100% of bubble within small circle
Incorrect level is less than 100% of bubble within small circle

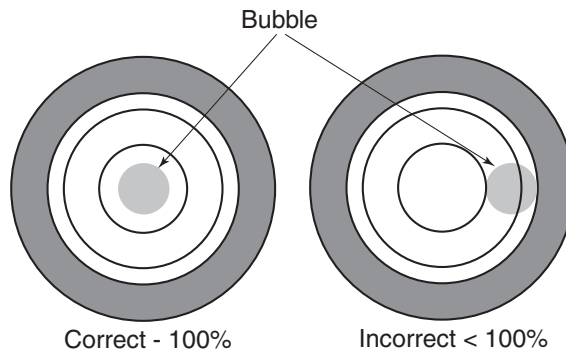


Figure 1-13 Bubble Level Centering

- 4.) Adjust the distance between floor and gantry base at Anchor location #1 becomes approximately 17.0 mm by turning four (4) adjusters equally.
(Be careful no more than 1 turn at a time.)

Section 7.0 Gantry Bearing Gap Inspection

All CT systems require a gantry bearing gap inspection before starting electrical calibration.

All international gantries are shipped in a wooden shipping crate that should not be removed until it arrives at the installation site. This shipping container is designed to reduce the risk of shipping damage.

The back cover needs to be removed to gain access to the gantry bearing.

7.1 Time and Personnel

Required Persons	Preliminary Reqs	Procedure	Finalization
2 (FE or mechanical supplier)	15 min	15 min	5 min

7.2 Tools and Test Equipment

- Standard tool kit
- Inspection document
- 2.5 mm Allen wrench
- Rear cover dollies (Qty = 2)
- Flashlight

7.3 Preparation: Damage Indicators

If this is a Rotek bearing, a mark similar to that shown in [Figure 1-14](#) is visible on the inside edge of the black-colored bearing assembly.

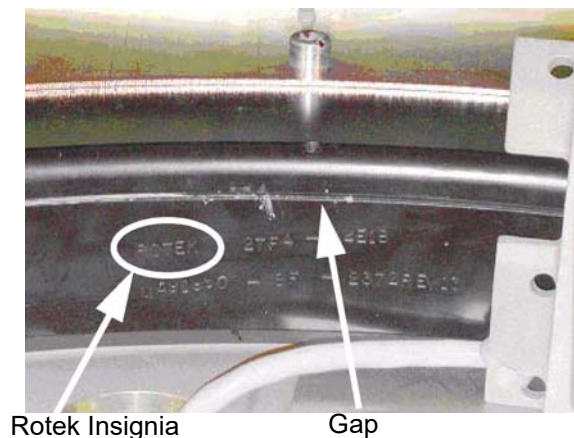
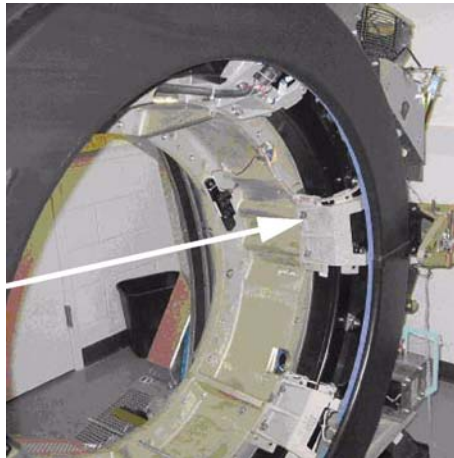


Figure 1-14 Gantry Bearing - Rotek Label

The mark has a serial number in the same format as:
 ROTEK 2TF4-44E1B-MA91960-8F-2372-REV13.

The gap to inspect is shown in [Figure 1-15](#) next to the serial number.



Bearing Surface

Figure 1-15 Gantry Bearing

On most systems, a change in the bearing gap does not cause the gantry to make unusual sounds, unless the gap is severe. If the gantry is badly damaged and the gap is severe, it can cause operation issues. Some systems are shipped with shock indicators that must be returned to Milwaukee.

A severe failure may be seen during installation as a problem rotating the gantry.

7.4 Procedure

- 1.) Remove the scan window.
- 2.) Remove the top cover and slide out the rear gantry cover.
- 3.) Slide out gantry bore cover by using the bore cover support tool (Refer to *Replacement > Gantry > Enclosure > Gantry Bore Cover Support Tool Usage* in Service Method CD)

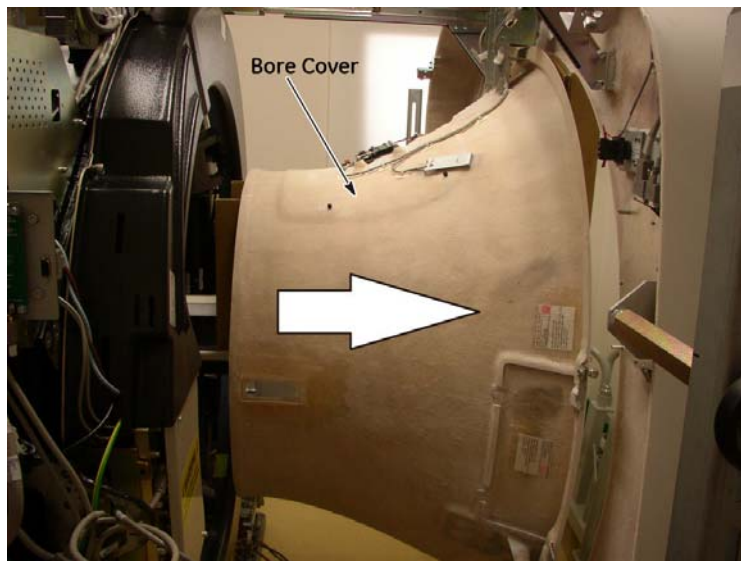


Figure 1-16 Gantry Bore Cover

- 4.) Use a 2.5 mm hex wrench as a tool to measure the gap at the positions shown in [Figure 1-17](#). The location of gantry components does not matter. Measure four (4) locations 90 degrees apart from each other.

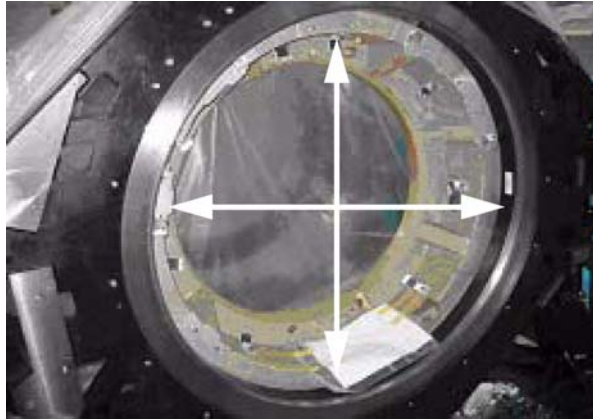


Figure 1-17 Inspection Locations

- 5.) If the 2.5 mm easily fits without effort in the gap, the gap is out of spec. [Figure 1-18](#) shows a gap that is too large in the left picture. [Figure 1-18](#) shows a gap that is good in the right picture. Notice that the hex wrench does not fit in the gap in [Figure 1-18](#) (left picture), but does in [Figure 1-18](#) (right picture).

Note: Do not use force when putting the wrench in the gap. Either it slips in or it doesn't.



Figure 1-18 Gap too large (left)



Gap is good (right)

7.5 Finalization

7.5.1 Mechanical Installers

If the Bearing Gap Inspection passes, complete the sign-off on the GE Form e4879, Installation Data verification form, that this inspection was completed.

If the Bearing Gap Inspection fails, contact your site FE.

7.5.2 FE Service Action, if Required

If the Bearing Gap Inspection fails, the mechanical installer notifies the site FE that the inspection failed.

The site FE should:

- 1.) Open a bearing inspection dispatch.
- 2.) Follow the inspection procedure described in this section.
- 3.) Record the bearing inspection results.

If no damage is found, close this dispatch and continue with the electrical calibration procedures.
If the system is damaged, go to the Equipment Delivery Quality web site and follow their instructions.

To enter a damaged in shipping claim, go to this web site:

<http://egems.med.ge.com/edq/home.jsp>

7.5.3 FE Inspection Completion

1.) After the Gantry Bearing Inspection is complete, close the service dispatch with the following information:

- Gantry Serial Number
- Gantry Type
- System ID
- Site Name
- Installation date
- Was the gantry transported to the site in the shipping crate? (Yes/No)
- Was the gantry lifted or hoisted, were riggers used, or was the gantry delivered via flatbed wrecker? (Yes/No)
- Number of locations that fail the gap inspection if any: _____

2.) Close the service dispatch.

Should any follow-up be required after this inspection, the site engineer will be contacted directly by CT Engineering.

Section 8.0 Install Gantry Alignment Laser and Bracket

8.1 Time and Personnel

Required Persons	Preliminary Reqs	Procedure	Finalization
2 (FE or mechanical supplier)			

8.2 Tools and Test Equipment

- Standard tool kit
- Laser Alignment kit (p/n 5272090)
- 9" level
- Tape measure
- Masking tape

8.3 Procedure

NOTICE Use caution while removing the gantry scan window.

- 1.) Rotate the gantry by hand until the collimator face plate is at the 5 o'clock position.

Note: With power OFF, the gantry movement is tight.

DO NOT pin the gantry during this alignment process.

- 2.) Remove the Gantry side, top, front, and rear covers.
- 3.) Disconnect two connectors from top of the bore cover.



Figure 1-19 Disconnecting two connectors

- 4.) Remove two (2) bottom bore cover screws and loosen the top bore cover screw.

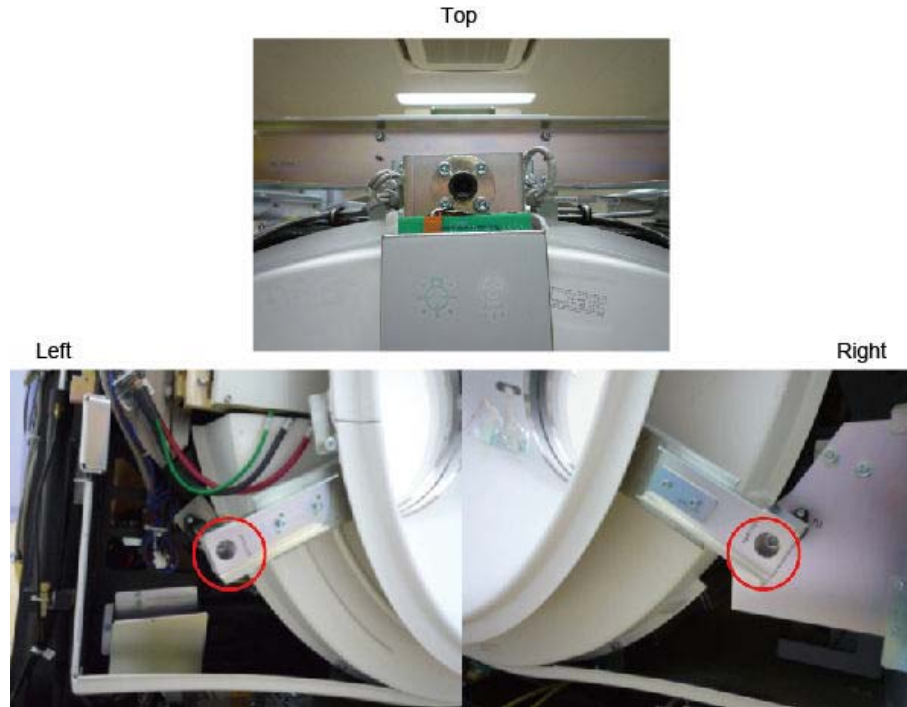


Figure 1-20 Bore Cover Screws

- 5.) Slide the bore cover about 5 cm (2 in.) so that the laser tool can be attached.



Figure 1-21 Sliding Bore cover backward

- 6.) With the Gantry top, rear, and bore covers removed, locate the two M10 bolt holes as shown in [Figure 1-22](#). These bolt holes are used to attach the laser tool to the gantry.
 - The bolts can be installed using an 8 mm Allen wrench. Be careful not to bump the alignment light; the mounting space is tight near the alignment light. Tighten bolts until both are snug.

- Do not drop bolts or the bar on the collimator faceplate. Attach the bar as shown in [Figure 1-22](#).
- Using a minimum 223 mm (9 in.) level placed on the attached bar, level the bar by rotating the gantry.



Figure 1-22 Alignment Bar Installation Location

CAUTION



Potential for injury.

DO NOT look into the laser.

Use appropriate safety procedures when working with lasers.

- 7.) Attach the laser centering plate onto the laser mounting bar as shown in [Figure 1-23](#). The plate is attached from under the alignment bar using two fixed locators and two thumb screws.

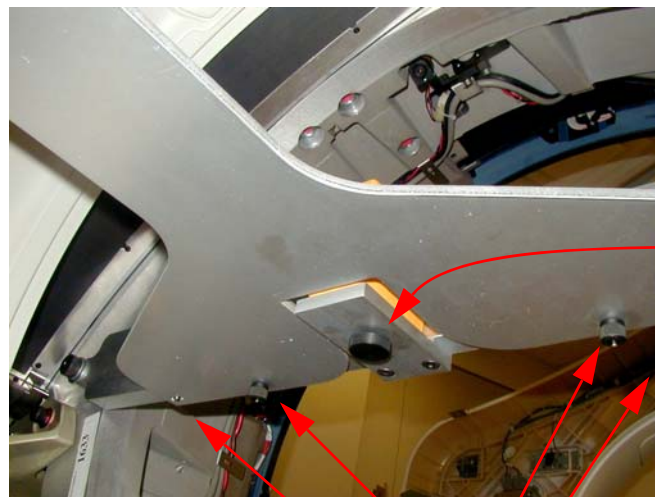


Figure 1-23 Attach Laser Center Plate

- 8.) When done, insert the laser and turn on the laser using the controls on the back. If the laser is loose when mounted, use a 2 in. piece of Velcro loop (fuzzy) section and attach it to the alignment plate over the attachment screw. Remount the laser and it should fit snugly without moving.

- 9.) When pressed, the **ON** button steps through four different beam profiles and "Self-Leveling Off". Press the **ON** button until the "I" beam shows. It is used for this operation.

Times pressed	Function	Notes
1	—	
2		Self-leveling on
3	+	
4	Self-leveling off	Do not use

Table 1-3 Laser On/Off Button

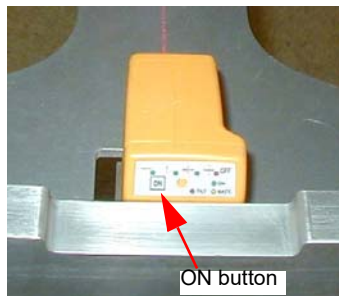


Figure 1-24 Laser ON button

- 10.) Align the laser by carefully rotating the laser base assembly so that the "I" beam shines through the center of the alignment sight mounted on the end of the alignment plate.

Note: The laser beam may be wider depending on the battery life.

- 11.) Use the locking screw on the bottom of the alignment bar to secure the laser to the bar, as shown in [Figure 1-25](#). When done, the laser should fit snugly without moving on the mounting bracket.

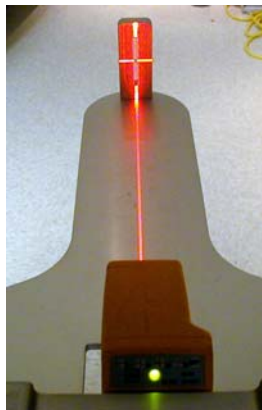


Figure 1-25 Laser Centering

CAUTION

When tightening, the laser may move. Use caution to prevent any movement, as this can result in drilling the table anchor holes in the wrong location.

- 12.) After the laser is centered, notice that the laser beam also appears on the back wall. Place a piece of masking on the wall and carefully mark a line on the tape where the laser appears. This line is later used in the table alignment. This line is also useful in determining if the laser unit moves during the alignment process.
- 13.) Remove the alignment centering plate and store it in the alignment case.
- 14.) Turn off the laser but do not remove.

Section 9.0 Table Installation (GT1700V)

Note: For Lite Table Installation, refer to [Section 10.0](#).

9.1 Time and Personnel

Required Persons	Preliminary Reqs	Procedure	Finalization
2 (FE or mechanical supplier)		1.5 hours labor on-site	

9.2 Tools and Test Equipment

- Standard Install Tool Kit
- 3/4", 1-1/4", 1-1/2" and 1-5/8" sockets
- 8mm, 10mm, and 14mm hex socket bits
- Laser Alignment kit
- Johnson Professional 6" level
- Johnson Professional 4' level
- Johnson Professional 2' level

9.3 Procedures

9.3.1 Draw Table Reference Lines

- 1.) Draw a reference line of 673 ± 6 mm ($26.5" \pm 0.25"$) position from Gantry Base on the floor as shown in the [Figure 1-26](#). This line should be parallel to the gantry. In a later section, you will move the table against the 673 mm ($26.5"$) mark.

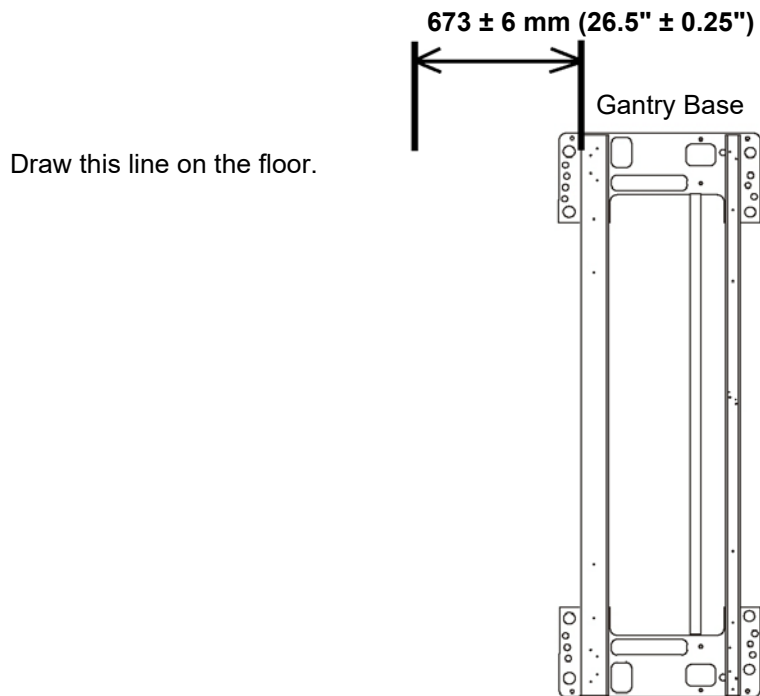


Figure 1-26 Draw Reference Line

- 2.) Using a chalk line, mark a table center line on the floor along the laser light shining on the floor.

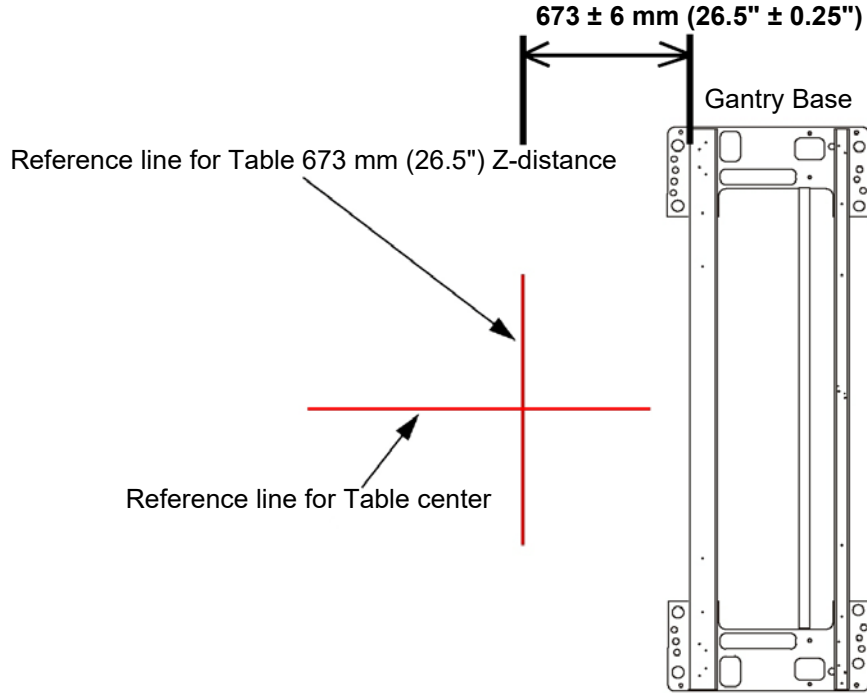


Figure 1-27 Draw Reference Line for Table Center

- 3.) Recheck the table-to-gantry reference line for $673 \pm 6 \text{ mm}$ ($26.5'' \pm 0.25''$) Z-distance. Refer to [Figure 1-27](#).
- 4.) Turn off the laser but do not remove.

9.3.2 Table Prep and Set-up

SAFETY

CAUTION

Potential for Electric Shock.

Equipment is Energized.

Follow appropriate safety procedures when working with an energized system.



CAUTION

Potential for Injury.

Table will tip if not anchored on the dolly.

Make certain that Table is adequately secured to the dolly.



CAUTION

Potential for Injury.

Table on dolly length is 2.5m (98 in.).

Exercise caution when moving the table on the dolly.



PROCEDURE

CAUTION

Potential for Injury.

Table will tip if not anchored on the dolly.

Make certain that Table is adequately secured to the dolly.



- 1.) Remove all the transportation packaging and boxes, except dollies, from the table. (See [Figure 1-28](#).) Leave a layer of packing material on the cradle to protect the cradle from damage. (It can be removed during laser alignment of the table.)



Figure 1-28 Remove Table Packing

- Note: The GT / VT table on dollies is approximately 118" long and may require additional room to maneuver.
- 2.) Unpack the items and locate all of the items needed to install the table.
 - 3.) Using the table centering and distance locator marks made earlier, wheel the table to its approximate position relative to the gantry.
 - 4.) Locate the table leveling pads inside the table in the back and on the side in the front. Preset leveling pad heights to 5/8" (15.5mm). (See [Figure 1-22](#).)

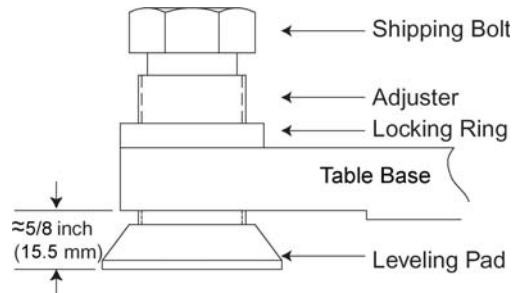


Figure 1-29 Table Base Leveling Pads (Starting Positions)

- 5.) Use a 1-5/8" socket and 1/2" ratchet to loosen the shipping bolt. Loosen the locking rings if present.
- 6.) A 1-1/8" socket is used with the adjuster tool if needed to lower the adjuster.
- 7.) Use the dollies to evenly lower the table until it rests on the leveling pads using a 1/2" ratchet on each end.



Back



Front

Figure 1-30 Adjusters and Lock Rings

9.3.3 Table Cover Removal

- 1.) Remove the table right side cover, as shown in [Figure 1-32](#).
 - a.) Removing the two screws on each end of the underside of the long side cover of the table.
 - b.) Slide each cover forward to unlatch, lift upward slightly to disengage the latches, and remove the side cover. Doing this procedure will require patience and practice to remove and replace this cover.

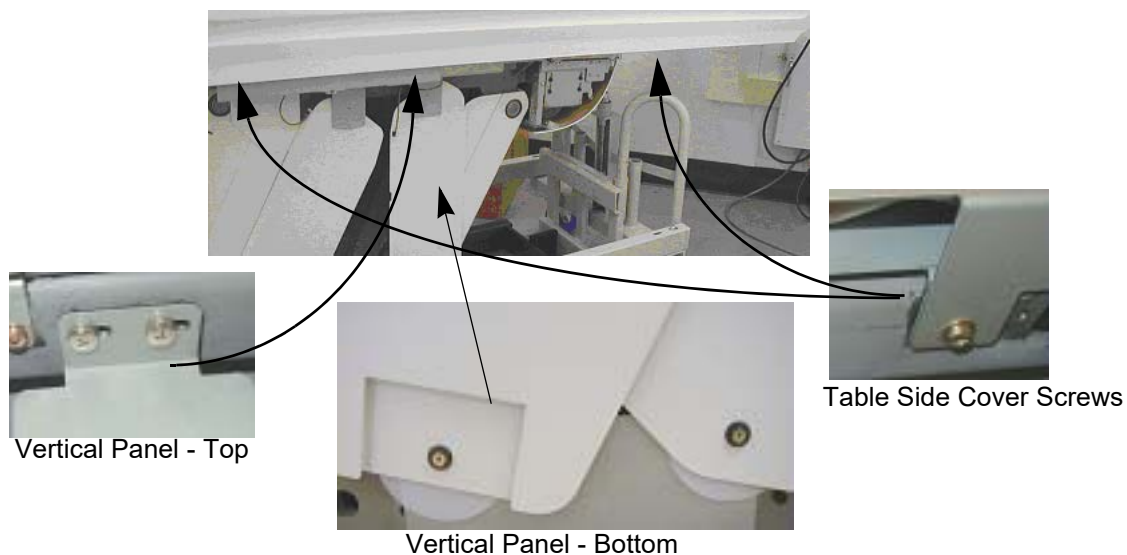


Figure 1-31 Table Covers

- 2.) The table is normally shipped with some of the side/vertical panels removed. If installed, remove the four side panels, using a Pozi drive #1 screwdriver.
- 3.) Carefully lay the side panels on protective padding out of the way.
- 4.) Make sure that all four of the table levelers are on the floor. The table should set on the four levelers with the dollies still installed.
- 5.) Carefully center the four levelers over the 4" (102mm) floor cutouts.
- 6.) Check that the front table base center line is on the chalk table center line.
- 7.) If still present, remove all packing materials and the table cradle pad from the table cradle.

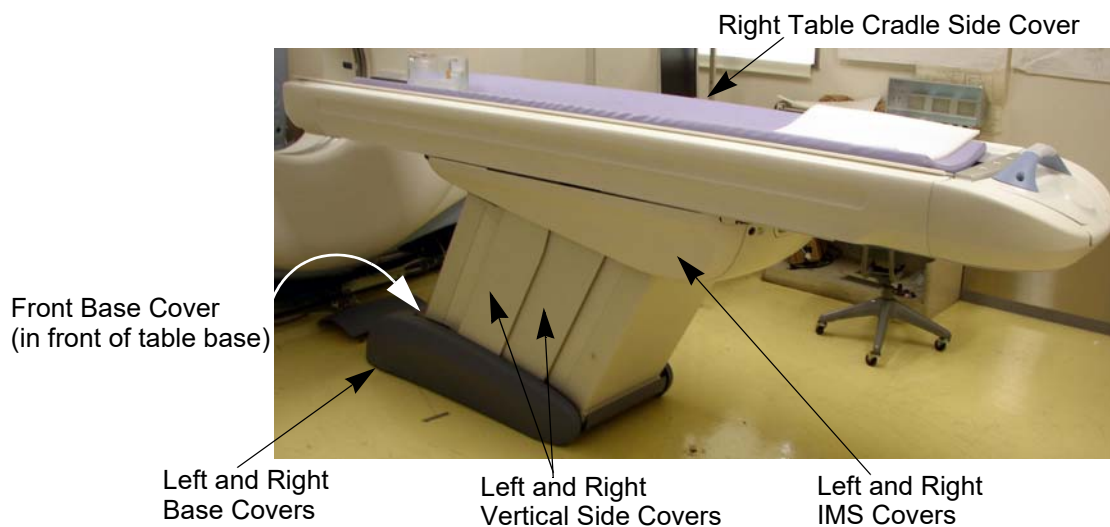


Figure 1-32 Table Covers

9.3.4 Removing the Accessory Rail Strip

- 1.) Remove the accessory mounting strip attached on each side of the cradle using a small flat blade screw driver. The nylon screws are inserted inside the accessory rail on the cradle.
- 2.) Place the accessory strips on the floor and reinstall the nylon screws into the accessory rail for safe keeping.



Figure 1-33 Accessory Rail Screw

9.3.5 Install the Table Cradle Laser Alignment Plates

- 1.) Locate the aluminum accessory tray mounting plate with the three holes on the rear of the cradle. Fit the rear alignment target into the two mounting holes as shown in Figure 1-34. Use the adjustment screw to adjust the fit as needed. See Figure 1-34. The fit should be snug, without play, when you are finished.



Figure 1-34 Cradle Rear Laser Alignment Tool

- 2.) Check that the table base is centered over the table center line, and the base is on the 26.5 in. line (± 0.25 in.) made on the floor.

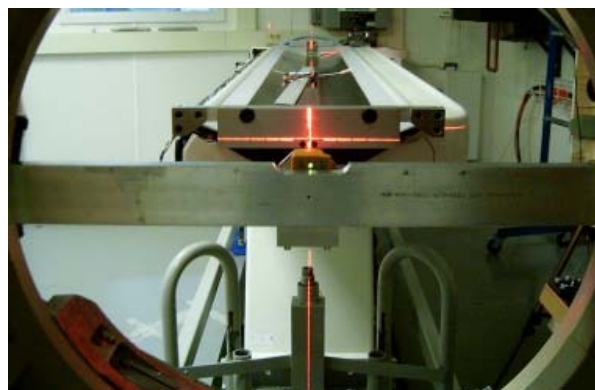


Figure 1-35 Rear Laser Alignment Tool - Installed

- 3.) Lower the table to the floor using the dollies, making sure to maintain the 673mm (26.5 in.) distance.

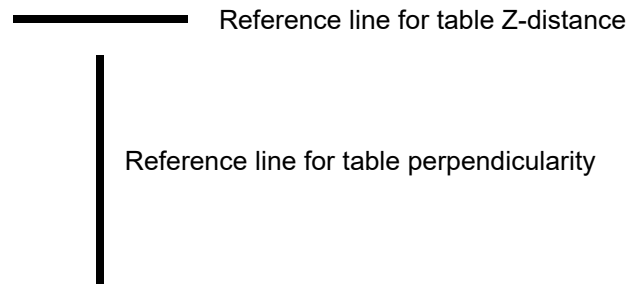
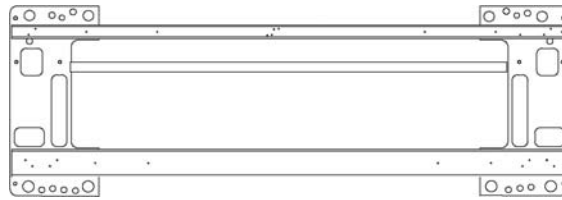


Figure 1-36 Two Reference Lines

9.3.6 Level and Center the Table to the Gantry

9.3.6.1 Conditions

- Before you start, turn on the laser and check that the beam is still on the mark placed on the wall. If not, reset the laser.
- If the mark is not present, use a measuring tape and place a 102 mm (4 in.) piece of masking tape on the cradle at the 1000 mm and on the laser line.
- Table base to cradle alignment location is 1005 mm from the center of cradle to the floor.

9.3.6.2 Specifications

- Table cradle must be level in all directions (centered within the lines on a Johnson Professional level).
- All table adjusters should be preset to 15.5 mm (5/8 in.) down from the table base to make adjustment easier. Based on floor levelness and your experience, a different preset height may work better. One thread must be showing above all locking rings when leveled.
- Table cannot be higher than 1005 mm from floor to cradle.

9.3.6.3 Procedure

NOTICE

Avoid leaning on the cradle during this procedure.
DO NOT pin the gantry during this alignment process.
This procedure as described is for systems mounted on 4 in. (102 mm) concrete floors only!

Note: If the floor covering was not properly removed with the glue removed or the levelers were not centered over the floor cutouts, the leveler may become trapped against the edge of the floor covering, causing the table to become unlevelled. If this happens, move the table and enlarge the 4 in. (102 mm) floor cutout for the table. Glue removal is important and aids in moving the table to its final location.

- 1.) Have the table side panels removed and have a ratchet, 1-1/8" socket, and a 2-foot level ready to use.
- 2.) Turn on the laser's "I" beam (vertical beams) by pressing the **ON** button 2 times.

- Note: [Step 4](#) through [Step 7](#) are for perpendicular positioning of the cradle to the gantry.
- 3.) The table on the dollies should be resting on the floor, and the laser beam visible on the cradle. The laser light should now shine down the cradle onto the rear vertical target. Moving the table on the dollies by raising and lowering makes it easier to center the table right to left.
- Note: When using the table dolly to move the table, be sure that the shipping bolts are still attached to the adjuster leveler feet.) This prevents the adjuster levelers from gripping on the floor adhesive, making it difficult to move.
- 4.) Move the table so that the base is roughly centered over the scan center line, the front edge of the table base is on the 673 mm (26.5 in.) line, and the table is resting on the floor. Check that the leveling feet are centered in the cutout circles.
 - 5.) Carefully move the table so that the cradle front center line and the back target are aligned. You may need to raise the table to move the table. When aligned, lower the table to the floor.
 - 6.) If not already done - Measure 1000mm from the front of the cradle, and place a piece of tape under the laser center line. Carefully mark a line along the laser line.
 - 7.) The laser beam should now connect the cradle front centerlines, the 1000 mm cradle center line, onto the rear alignment tool vertical center and finally onto the alignment centering mark placed on the wall. The centering alignment line on the wall is used to be sure the laser is still centered. If the alignment line on the wall is NOT on the original mark, readjust the laser and repeat the above steps. See [Figure 1-37](#).

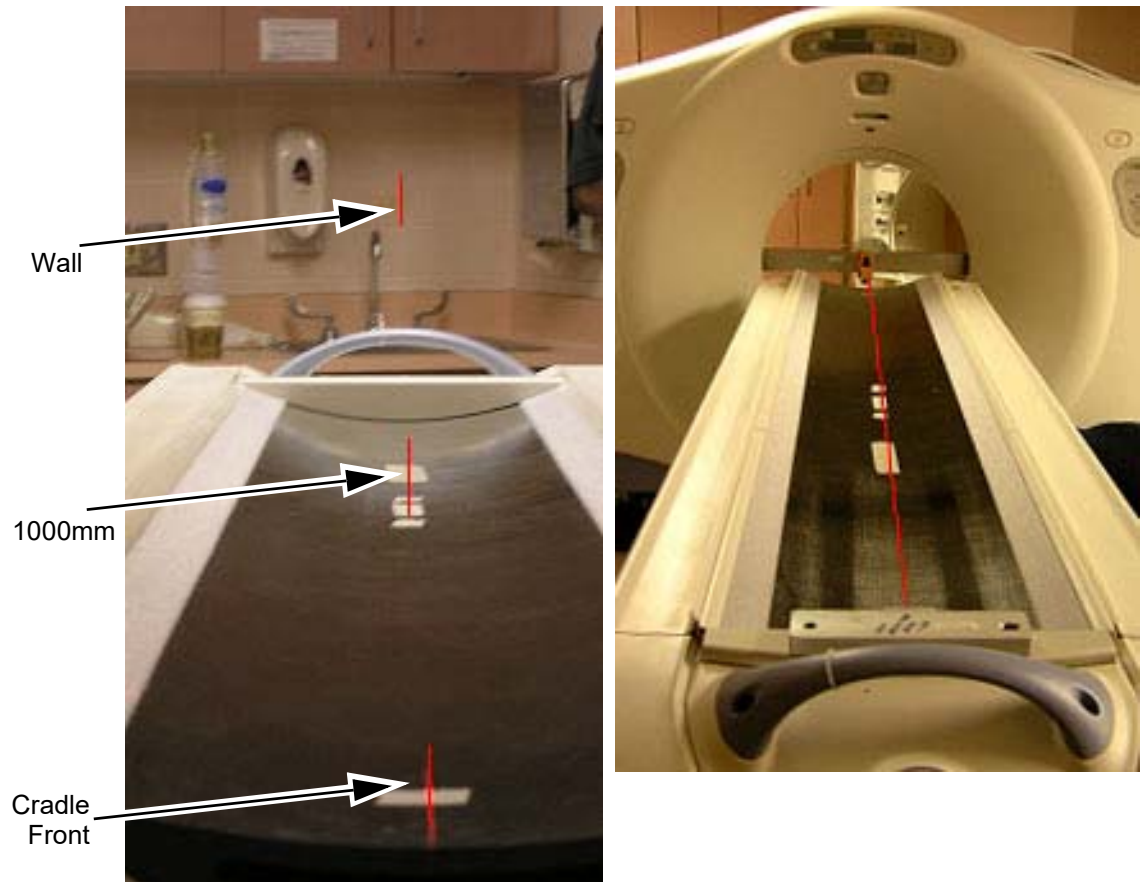


Figure 1-37 Alignment Laser Marks - Table & Wall

- Note: [Step 8](#) through [Step 10](#) are for front-to-back and side-to-side leveling of the cradle.
- 8.) The table should be completely on the floor and resting on all 4 levelers. Carefully remove one side of the table dolly, taking care not to bump or move the table. Either side and/or end of the table dolly assembly can be removed.



CAUTION Potential for Injury.

In the ship position, the table tips easily!

DO NOT lean on the table! The shipping bracket should still be in place!

9.) Place the bubble level on the table base. Refer to [Figure 1-38](#).

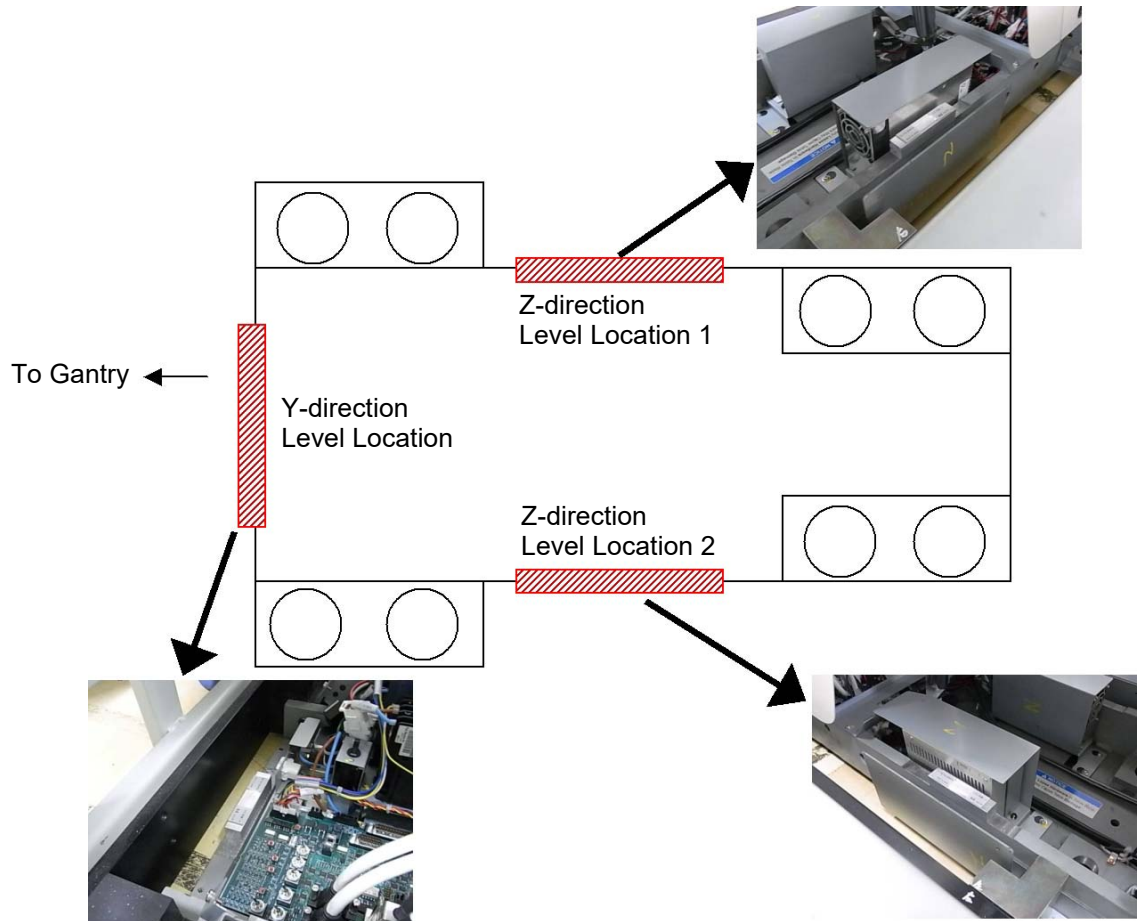


Figure 1-38 Level Location on the Table Base

10.) Raise or lower the table as needed using the front and rear levelers and level the table base in the Z-direction (2 positions) and the Y-direction (1 position).

This process is complete when:

- The cradle is still centered on the front, mid, and rear marks.
- The cradle is leveled in the Z-direction at 2 positions shown in [Figure 1-38](#).
- The bubble is leveled in the Y direction.
- The laser is still centered on the wall center line.
- The table is still on the 26.5" line and the levelers are not resting on the flooring.
- The laser is the same as in [Step 7](#).

Note: The leveling process may take several iterations of [Step 1](#) through [Step 10](#). Patience and accuracy is required to properly complete this process.

11.) When completed, turn off the laser tool.

Note: Do not remove the table dollies.

9.3.7 Tighten the Lock Rings

- 1.) Re-check gantry bubble levels.
- 2.) Re-check that each of the eight adjuster is loaded by attempting to turn it.
- 3.) Tighten the lock rings at all locations with the spanner, where possible. Use a hammer and chisel to tighten the lock rings only where you can not use the spanner.

CAUTION



Eye protection is required when using a hammer and chisel.

Section 10.0 Table Installation (Lite Table)

10.1 Time and Personnel

Required Persons	Preliminary Reqs	Procedure	Finalization
2 (FE or mechanical supplier)		1.5 hours labor on-site	

10.2 Tools and Test Equipment

- Standard Install Tool Kit
- 3/4", 1-1/4", 1-1/2" and 1-5/8" sockets
- 8mm, 10mm, and 14mm hex socket bits
- Laser Alignment kit
- Johnson Professional 6" level
- Johnson Professional 4' level
- Johnson Professional 2' level

10.3 Procedures

10.3.1 Draw Table Reference Lines

- 1.) Draw a reference line of 564mm position from Gantry Base on the floor as shown in the [Figure 1-39](#).

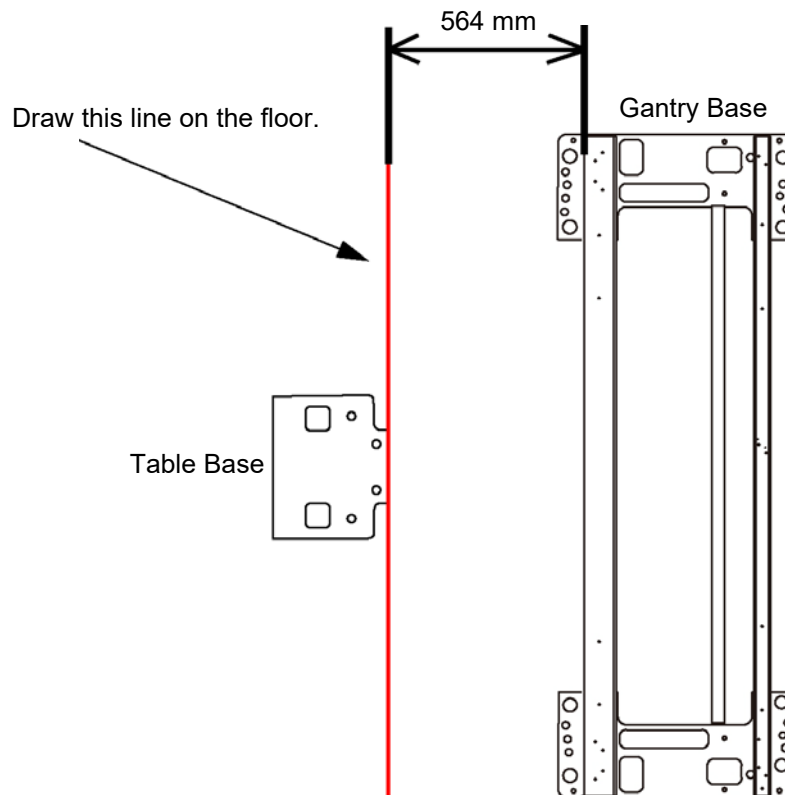


Figure 1-39 Draw Reference Line

- 2.) Remove all the transportation packaging and boxes, except dollies, from the table.
- 3.) Wheel the table to its approximate position relative to the gantry, using the marks made earlier.
 - a.) Locate the table leveling pads and position them against the base of the table, using the adjusters with a 1½" socket and ½" ratchet.
 - b.) Use the dollies to evenly lower the table until it rests on the leveling pads using an ½" ratchet.

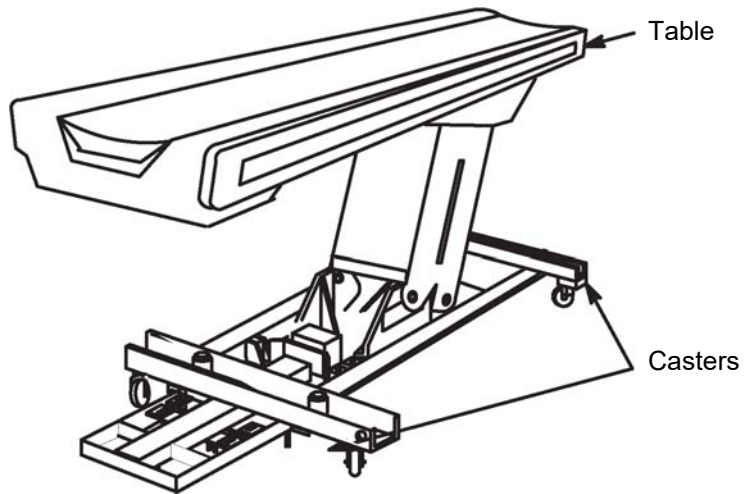


Figure 1-40 Moving the Table

- 4.) Preset leveling pad heights to 20mm, see [Figure 1-41](#).

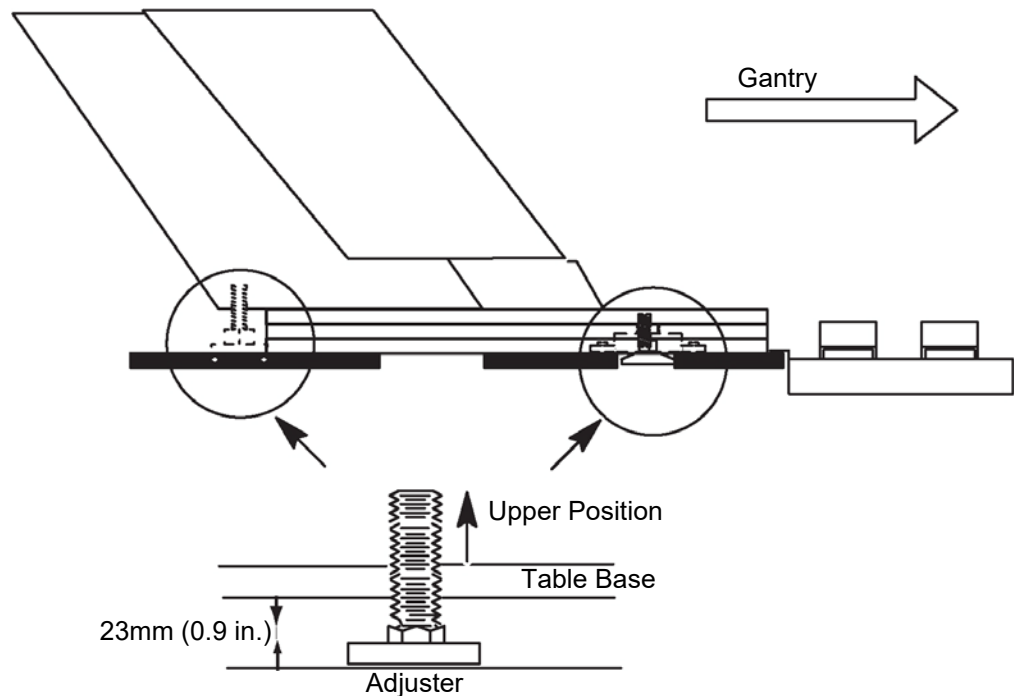


Figure 1-41 Setting the Adjusters

To adjust two leveling pads at rear end of table, please insert the screw driver into the hole located on the bolt then rotate the bolt, refer to the [Figure 1-42](#).

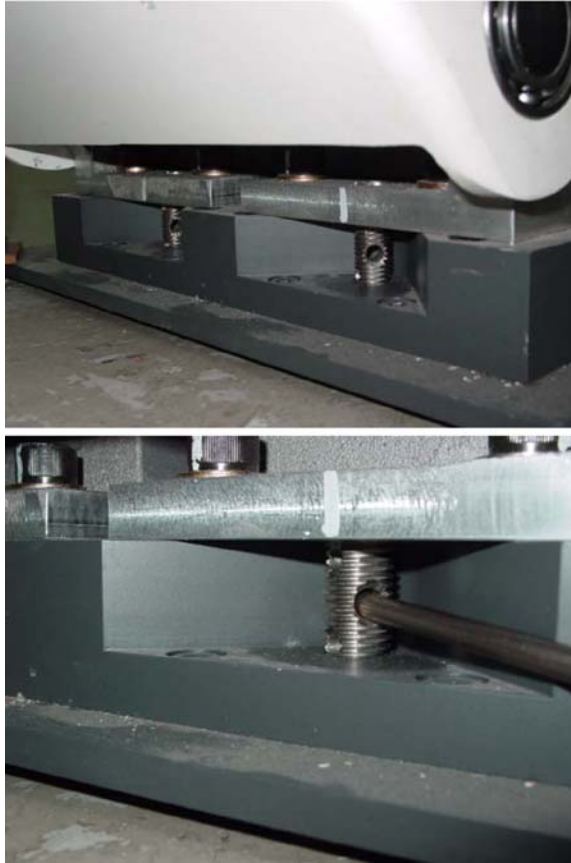


Figure 1-42 Adjust Leveling Pads

10.3.2 Cradle Center Procedure

- 1.) Remove a bottom cover under a cradle handle. See [Figure 1-43](#).



Figure 1-43 Remove Bottom Cover

- 2.) Release a latch by pushing a bracket to move the cradle by hands. See [Figure 1-44](#).

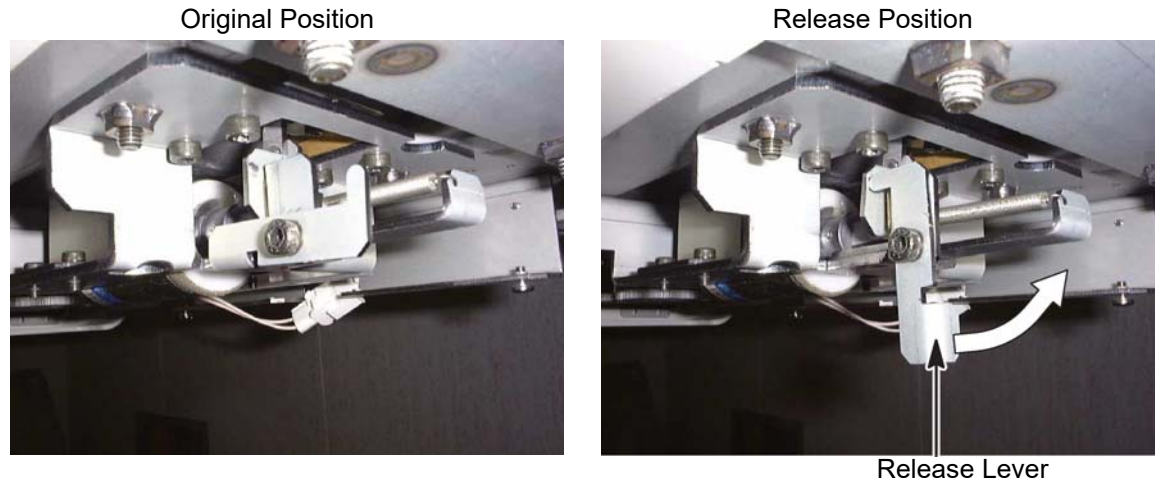


Figure 1-44 Release the Cradle

- 3.) Center the cradle on the drive rollers assembly by pushing the cradle into the gantry to its maximum position and back to just before the latch position six times. The cradle should be centered.

You must push and pull a center of cradle hand. See [Figure 1-45](#).



Figure 1-45 Push and Pull Cradle

10.3.3 Install the Table Cradle Laser Alignment Plates

Required tool: TG-alignment tool 5180876

- 1.) Install the front table laser alignment which has a cross slot to the front of the cradle.
 - a.) Loose adjustment knob to make the slot plate free.
 - b.) The slot in the front of the tool should be over the cradle center-line. See [Figure 1-46](#).



Figure 1-46 Front Table Laser Alignment

- c.) Tighten adjustment knob.
- 2.) Install the rear table laser alignment which has a cross target to the back of the cradle.
 - a.) Loose adjustment knob to make the slot plate free.
 - b.) The slot of the tool should be over the cradle center-line. See [Figure 1-47](#).



Figure 1-47 Rear Table Laser Alignment

- c.) Tighten adjustment knob.
- 3.) Check that table base is centered over the table center line, and the base is on the 564mm line made on the floor, see [Figure 1-39](#).

10.3.4 Level and Center the Table to the Gantry

10.3.4.1 Conditions

- Before you start, turn on the laser and check that the beam is still on the mark placed on the wall. If not, reset the laser.
- If the mark is not present, use a measuring tape and place a 102 mm (4 in.) piece of masking tape on the cradle at the 1000 mm and on the laser line.
- Table base to cradle alignment location is 1005 mm from the center of cradle to the floor.

10.3.4.2 Specifications

- Table cradle must be level in all directions (centered within the lines on a Johnson Professional level).
- All table adjusters should be preset to 20 mm (3/4 in.) down from the table base to make adjustment easier. Based on floor levelness and your experience, a different preset height may work better. One thread must be showing above all locking rings when leveled.
- Table cannot be higher than 1005 mm from floor to cradle.

10.3.4.3 Procedure

NOTICE Avoid leaning on the cradle during this procedure.
DO NOT pin the gantry during this alignment process.
This procedure is for systems mounted on 102 mm (4 in.) concrete floors only!

Note: If the floor covering was not properly removed with the glue removed, or the levelers were not centered over the floor cutouts, the leveler may become trapped against the edge of the floor covering, causing the table to become unlevel. If this happens, move the table and enlarge the 102 mm (4 in.) floor cutout for the table. Glue removal is important and aids in moving the table to its final location in accordance with the floor levelness specification.

- 1.) Place the bubble level on the table base . See [Figure 1-48](#).



Figure 1-48 Place Bubble Level

- 2.) Turn on the laser's "I" beam (vertical beam) by pressing the ON button 2 times.
- 3.) With the laser on, the laser light should shine through the front tool down the cradle connecting the front and rear center lines and onto the center of the rear alignment tool.
- 4.) Raise or lower the table as needed using the two front and two rear adjusters so that this line is shining 100% in the machined grooves of each alignment tool. (it is easier to raise, move, and lower the table using the table dolly. This prevents the adjuster levelers from gripping on the floor adhesive, making it difficult to move.)
 - a.) The light will shine vertically down the table.
 - b.) Both center lines on the cradle front and rear should be connected when done.
 - c.) Level of the table influences a center position, The vertical laser alignment light must match and be centered on the white line on the front of the table and in the groove of back alignment plate. See [Figure 1-49](#).

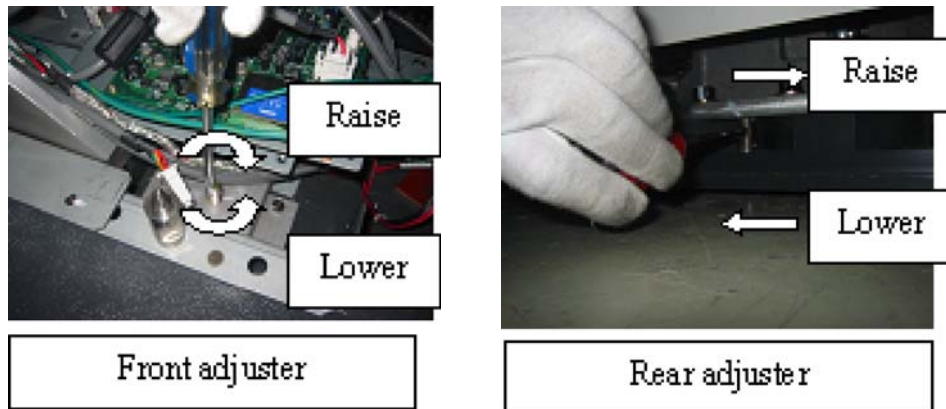


Figure 1-49 Front and Rear Adjuster

- 5.) Be sure that all adjusters bear part of table's load.

Section 11.0 Drill the Anchor Holes



WARNING POTENTIAL FOR PATIENT INJURY.
IMPROPERLY SECURED TABLE MAY TIP, DISLODGING PATIENT.
PROPER ANCHORING IS KEY TO MAINTAINING PATIENT SAFETY DURING SYSTEM OPERATION.

11.1 Notes to Mechanical Installers

Note 1: Basic Anchoring Information

GE provided floor anchors are designed for use ONLY on concrete floors that meet the 4-inch concrete floor requirement. Supplied floor anchors must be installed by a trained contractor, and shall be set to a minimum depth of 3-inches at each anchor point. ANY anchors having more than 1-inch of thread showing above the nut, when specified torque is set, shall have a second anchor installed in the closest adjacent hole. This is because the minimum anchor engagement length in the concrete was not met. The second anchor shall be installed to the standard depth and torque specification. Do not cut anchor bolts that extend longer than the 1-inch limit.

Note 2: Alternate Anchoring

If at least four anchors cannot be set for the gantry, and at least four anchors for the table using the alternate anchor holes, then the installer must inform the PMI that the minimum anchoring cannot be met. Additionally, the customer's structural engineering contractor must be engaged to determine the anchoring method, set the anchors, and certify that their anchoring meets the stated GE minimum load requirement and torque specification.

Note 3: Non-Concrete Floors

All other anchoring methods - on floor types other than the concrete minimum - must be determined at the customer's expense by a structural engineering contractor. The anchoring and method must be certified by the customer's contractor to meet the stated GE minimum load requirement and torque specification.

Note 4: GE Notification

It is not the role of mechanical contractors or installers (FEs) to determine acceptable methods to install or anchor equipment on non-4-inch concrete floors. The PMI or appropriate GE contact person shall be notified that the facility's floor type DOES NOT MEET the installation mounting requirement for the installation procedure (described in this Installation Manual), and therefore the table-gantry mounting process CANNOT continue.

11.2 Requirements

Tools Required

- Standard Install Tool Kit
- Hammer Drill
- ½" x 12" Drill Bit (Metric equivalent must not be used)
- ½" Drill Bushing (shipped in install support kit)
- Vacuum with HEPA or drywall dust filter
- Vacuum Hole Attachment - to clean debris from the holes

- PPE

Time and Personnel

- .5 hour labor on site
- 2 Engineers

11.3 Drilling Procedure (For Gantry and GT1700V Table)

For Lite Table drilling procedure, refer to [11.4 Drilling Procedure \(For Lite Table\)](#), on page 74.

Note: The gantry rear cover should still be removed and the table should still be on the dolly.

- 1.) Make sure that all table and gantry levelers (four each) are firmly on the concrete floor.

NOTICE
 Potential for
 Equipment
 Damage from
 Dust

To prevent damage due to the dust created during drilling, you must cover all electronic assemblies in the table base prior to drilling.

- 2.) Locate the hammer drill and 1/2" X 12" drill bit. The 1/2" bit will be used to drill all eight (8) table and gantry anchor holes. You must use the drilling bushing to drill gantry holes. All primary holes can be drilled with the gantry covers installed.

NOTICE

There are several types of anchors used in this product depending on the manufacturing date and Table type. Make sure which anchor is shipped with system before starting drilling procedure. For Table anchoring, use the anchors which are shipped with the Table.

Note: Drilling bushing cannot be used for the table holes.

- 3.) Apply a piece of adhesive tape (see [Figure 1-50](#)) which will then provide a visual means of making sure the proper hole depth has been reached.

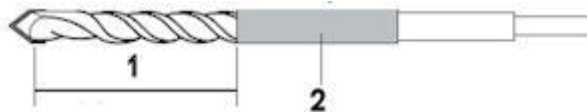


Figure 1-50 Drill Bit

Table 1-4 Drill Depth Gauge Mark Tape Location

	Anchor P/N: 2106573	Anchor P/N: 5487992-2
1	91mm (3.58 inches)	85mm (3.35 inches)
2	Adhesive Tape	Adhesive Tape

- 4.) Use the 1/2" bit to drill all eight (8) anchor holes to a specified depth as measured from the top of the drill bushing. Review [Figure 1-51](#) and [Figure 1-52](#) prior to drilling.

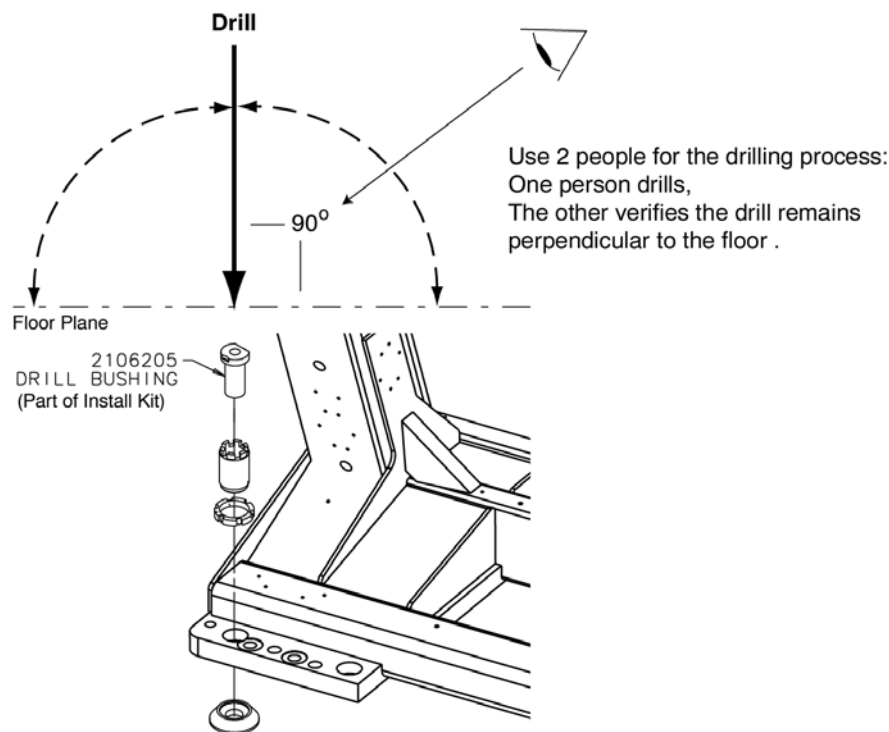


Figure 1-51 Drilling Position

- 5.) Place appropriate protection to prevent damage and dust contamination to electronic assemblies.
- 6.) Place the drill bushing inside each adjuster, to keep the hole vertical and centered within the adjuster.
 - Use the drill bushing to center the anchor holes in all adjuster locations, to provide maximum lateral alignment capacity when you center the cradle on isocenter during subsequent system testing.
 - Take care not to injure yourself on the gantry cover brackets.
- 7.) Drill the holes perpendicular to the floor.

Important - Follow these guidelines when drilling anchor holes:

- While one person drills the holes, position a second person to watch the relationship between the drill bit and floor. Make sure the bit remains absolutely perpendicular to the floor throughout the drilling operation.
- Always use the mechanical guide when drilling.
- Stop drilling every 15 or 20 seconds and clear the hole of debris. This lets the drill bit cool and helps to prevent binding of the drill bit.
- Vacuum while drilling to keep gantry and table as free of dust contamination as possible. Place the funnel tip or long extension tip inside the hole.

A drywall dust filter must be used on the vacuum.

- Drill each hole until the mark on the drill bit is even with the top of the drill bushing. All holes must have a depth specified in [Table 1-4](#), as measured from the top of the adjuster to the bottom of the hole. (See [Figure 1-58](#), on page 79) Use an upside-down anchor to check the hole depth.

- 8.) Recheck the depth of all holes by inserting an anchor backward into the hole. A 1/2" (13mm) or less should be showing. Re-drill if needed.
- 9.) When finished drilling and clearing the anchor holes, vacuum the debris from the inside of each of the holes and from the surrounding (floor) area.

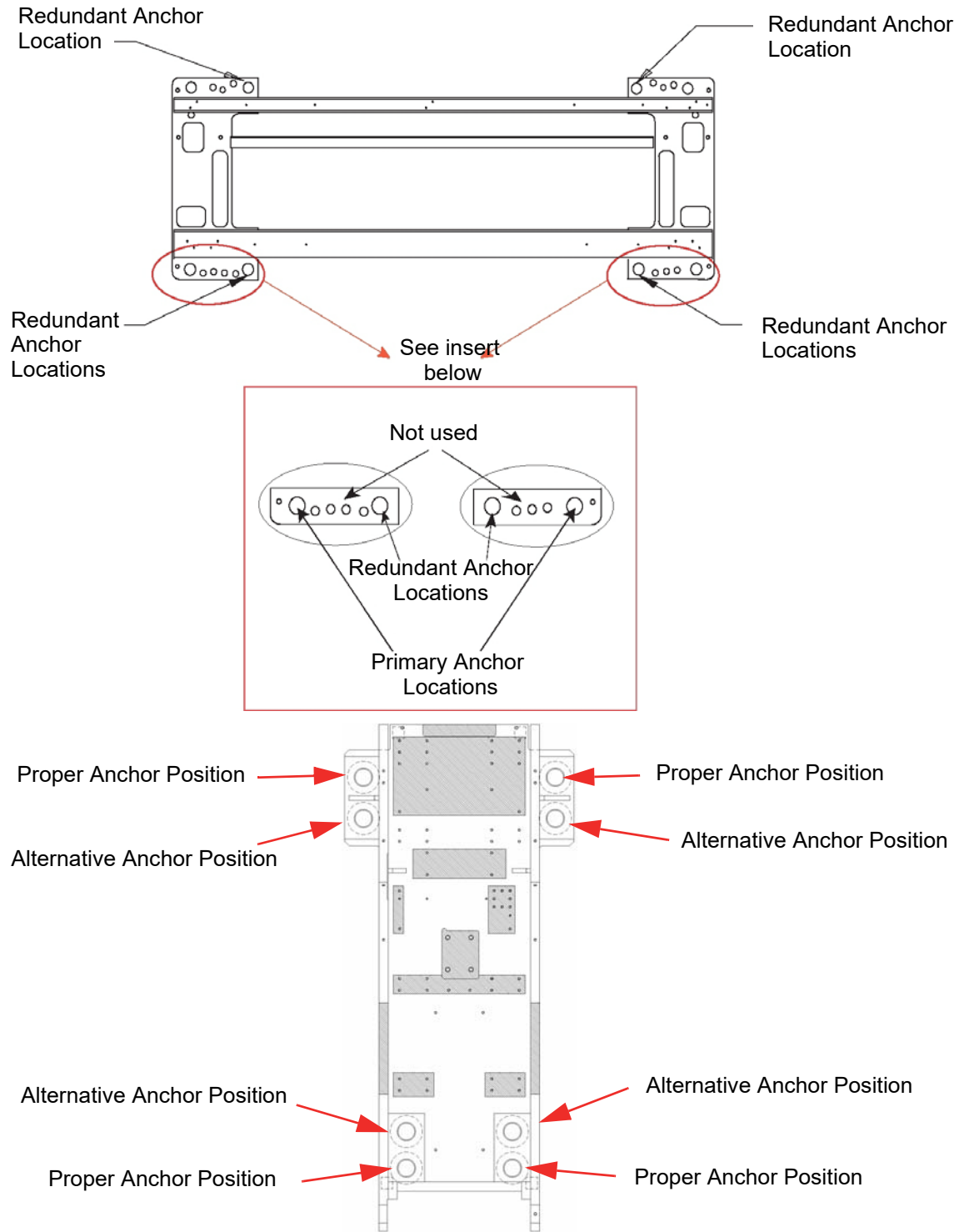


Figure 1-52 Anchor Locations

Note: If alternate location(s) are used to anchor the table or gantry, you must move the respective leveler(s) and pad(s) to the new alternate location(s) and re-drill.

11.4 Drilling Procedure (For Lite Table)

When the room-layout template is used, the anchor bolts have been installed. If it is, perform the following. If it is NOT, perform all procedures of this section.

- Table Leveling (This section)
- Tighten the anchor nuts with the insulating plate and washer.

TORQUE: Approx. 5 N-m

NOTICE Do not tighten the anchor nuts to the specified torque (50 N-m). To over-tighten nuts will damage the frame of the Gantry and also bring an out-of-level Gantry.

- Verify that the Table to Gantry Alignment should be correct.

This anchoring procedure is one for the anchor kit shipped with the system.

NOTICE The minimum Tensile load strength of the anchor must be 13000 N.

- 1.) Verify that the table flapper is removed to make space for anchoring. If it is not, remove the table flapper by removing the four flapper Assy mounting bolts.

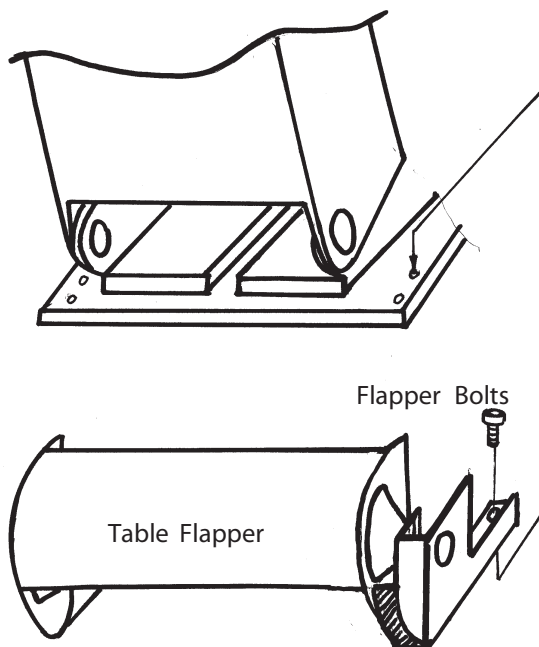


Figure 1-53 Table Flapper Removal

- 2.) Prepare and tape ½" concrete drill bit.
- 3.) Make holes at the anchor position as shown in [Figure 1-38](#), using electric drill with the bit prepared in the previous step, so that the lower edge of the tape just touch the floor surface.

NOTICE During drilling, always keep the drill bit perpendicular to the floor. With one person drilling the hole, a second person can visually insure perpendicularity throughout the drilling operation. Clear the hole of debris several times while drilling to prevent the drill bit from binding.

- 4.) Attach a piece of tape to the 1/2" concrete drill bit in order to assure a minimum of 100 mm depth of anchor hole.
- 5.) 1/2" Concrete Drill Bit Preparation

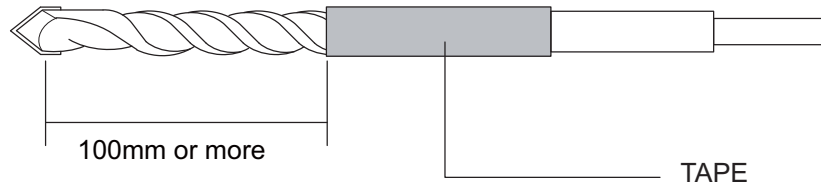


Figure 1-54 Drill Bit Preparation

- 6.) Use the vacuum cleaner to suck up the concrete dust from the hole. Also vacuum dust from the surrounding area when finished.
- 7.) Place the bubble level at the positions.
- 8.) Level the Table using the four adjusters. (The front sides of the adjuster contain the lock nut. After level adjustment, tighten the lock nuts securely.)

Level Specification: +/- 0.5 mm/1000 mm

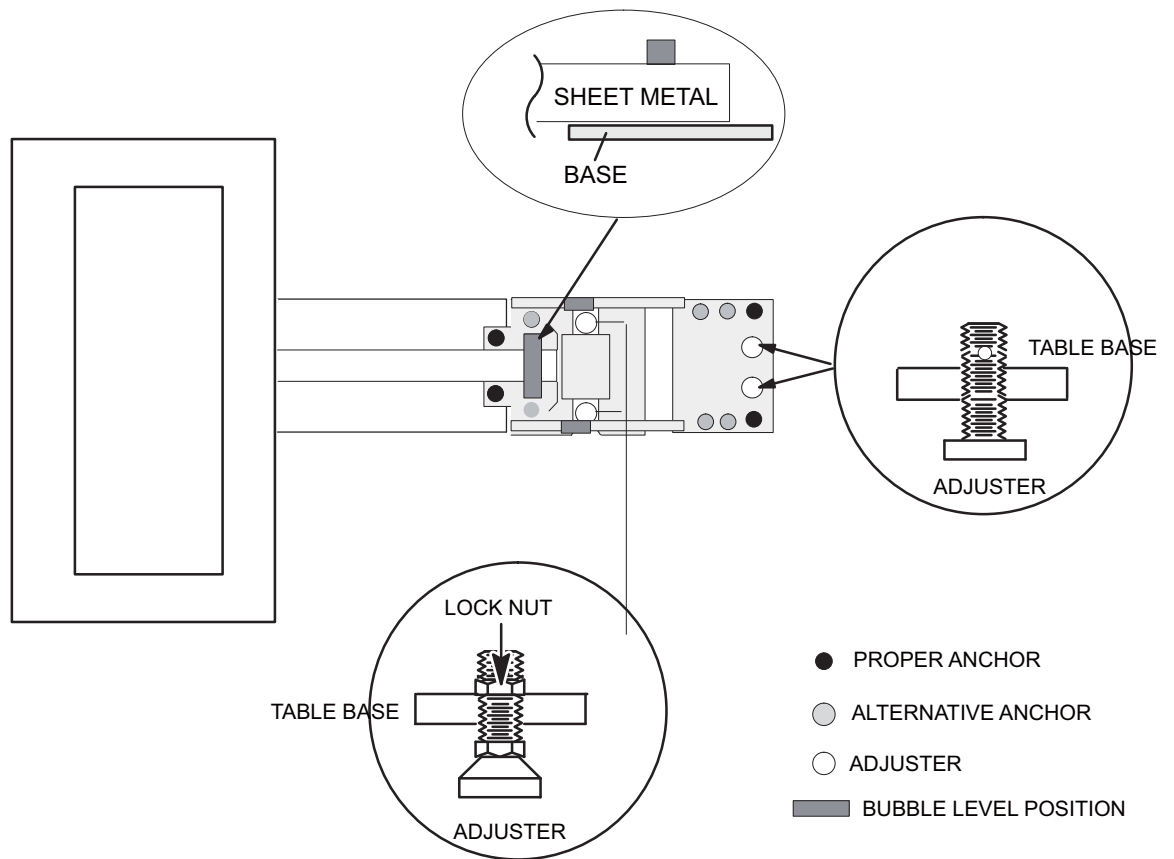


Figure 1-55 Table Adjuster and Bubble Level Position

- 9.) Check that the Cradle is also leveled.

11.5 Gantry & Table (GT1700V) Alternate Anchor Holes

For Lite Table alternate anchor holes procedure, refer to [11.6 Lite Table Redundant Anchor Holes, on page 77](#).

If you cannot use one of the adjuster anchor holes due to structural interference, such as reinforcement bars in the concrete, you must use one of the alternate anchor locations, as shown in [Figure 1-52](#). You must also move the respective leveler(s) and pad(s) to the new alternate location(s) and re-drill.

Note: Do not remove the adjuster to move to the alternate anchor hole.

- The gantry requires a minimum of four (4) anchors, one (1) in each corner.
- The table requires a minimum of four (4) anchors, one (1) at location.

If you must use an alternate anchor hole in the gantry, you must remove the gantry covers to drill the holes. See [Appendix A Gantry Cover Removal and Dolly Setup, on page 189](#) for gantry cover removal.

WARNING



POTENTIAL FOR PATIENT INJURY.

IMPROPERLY-SECURED TABLE MAY TIP, DISLODGING PATIENT.

PROPER ANCHORING IS KEY TO MAINTAINING PATIENT SAFETY DURING SYSTEM OPERATION.

It is the purchaser's responsibility to provide an approved support structure and mounting method for all floor types other than those listed. General Electric is not responsible for any failure of the support structure or method of anchoring, including seismic requirements and/or through-bolting.

Note: GE is not responsible for anchoring methods other than those listed in the pre-installation manual. Provided floor anchors are designed for use ONLY on concrete floors that meet the 4-inch concrete floor requirements.

MOUNTING REQUIREMENTS	ANCHOR P/N 2106573	ANCHOR P/N 5487992-2
Minimum Floor Thickness:	102 mm (4 in.)	102 mm (4 in.)
Recommended Drilling Depth:	91 mm (3.58 in.)	85 mm (3.35 in.)
Minimum Anchor Embedment:	78 mm (3.07 in.)	75 mm (2.95 in.)
Available Alternate Anchor Locations:	Yes	Yes
Shipped Anchor Size:	203 mm (8 in.)	178 mm (7 in.)
Alternate Anchoring Methods:	Yes (see notes, above)	Yes (see notes, above)
Floor Levelness Requirement:	6 mm (1/4 in.) over 3 m (10 ft.)	6 mm (1/4 in.) over 3 m (10 ft.)

Table 1-5 Gantry and Table Mounting Requirements

11.6 Lite Table Redundant Anchor Holes

The table requires a minimum of four (4) anchors, one (1) in each corner of table base.

Note: If any obstruction is found under the proper anchoring position, stop drilling and use the alternate position (see Figure 1-56). Use the alternate positions only when the case its corresponding proper position is not possible.

MOUNTING REQUIREMENTS	ANCHOR P/N 2106573-3
Minimum Floor Thickness:	110 mm (4-1/3 in.)
Recommended Drilling Depth:	100 mm (4 in.)
Average Anchor Embedment:	90 mm (3-½ in.)
Minimum Anchor Embedment:	80 mm (3 in.)
Available Alternate Anchor Locations:	Yes
Shipped Anchor Size:	140 mm (5-½ in.)
Alternate Anchoring Methods:	Yes (see notes, above)
Floor Levelness Requirement:	6 mm (1/4 in.) over 3 m (10 ft.)

Table 1-6 Lite Table Mounting Requirements

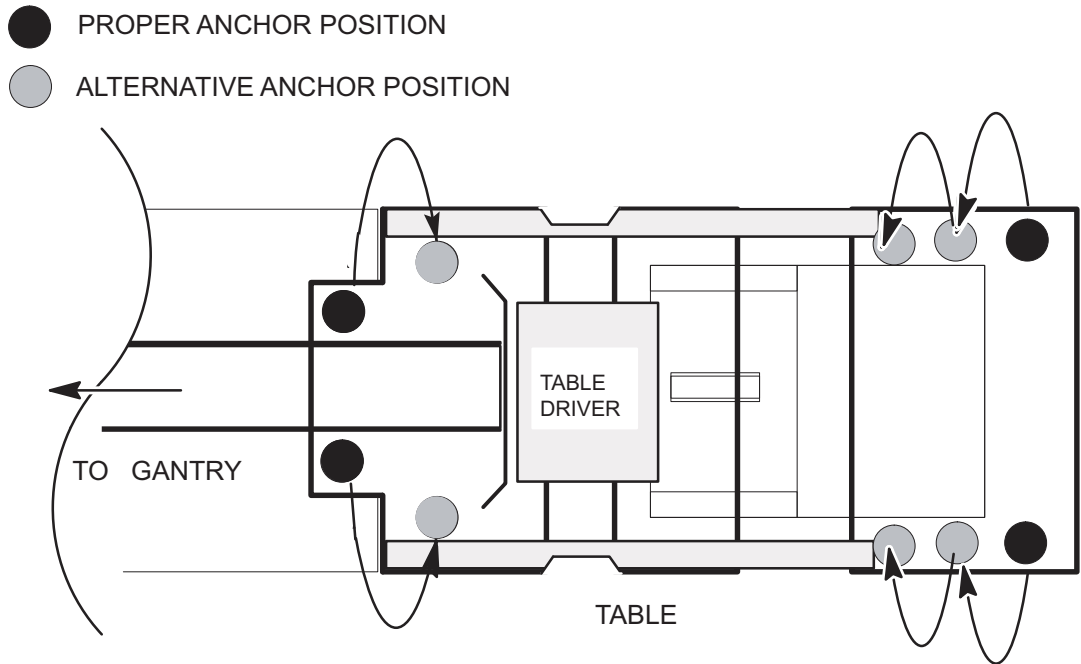


Figure 1-56 Lite Table Anchor Positions (Proper and Alternative)

11.7 Install the Anchors (For Gantry and GT1700V Table)

For Lite Table anchor procedure, refer to [11.8 Install the Anchors \(For Lite Table\)](#), on page 80.

NOTICE Each anchor must be prepared by installing a nut 13.0 mm from the top of the anchor as measured from the top of the anchor to the top of the nut. before inserting and setting them in their respective anchor hole. failing to do this may result in anchor failure.

NOTICE The anchors will bend if they are hit too hard with a hammer. Strike the anchor with sufficient force to drive it down into the hole so the washer touches the leveling screw.

- 1.) Prepare each anchor by installing the large flat washer and nut on to each anchor. Adjust the nut so there is 13.0 mm between the top of the anchor and top of the nut.



Figure 1-57 Anchor Preparation-set nut at 13.0 mm

- 2.) Place another nut on the anchor and thread it on far enough so it is flush with the top of the anchor. This nut will protect the threads.
- 3.) Insert an anchor into each anchor hole in the gantry and set the anchors with a hammer. The washer should touch the leveling screw if the anchor is installed and set properly.
- 4.) Remove the nuts placed on the anchors to protect the end threads.

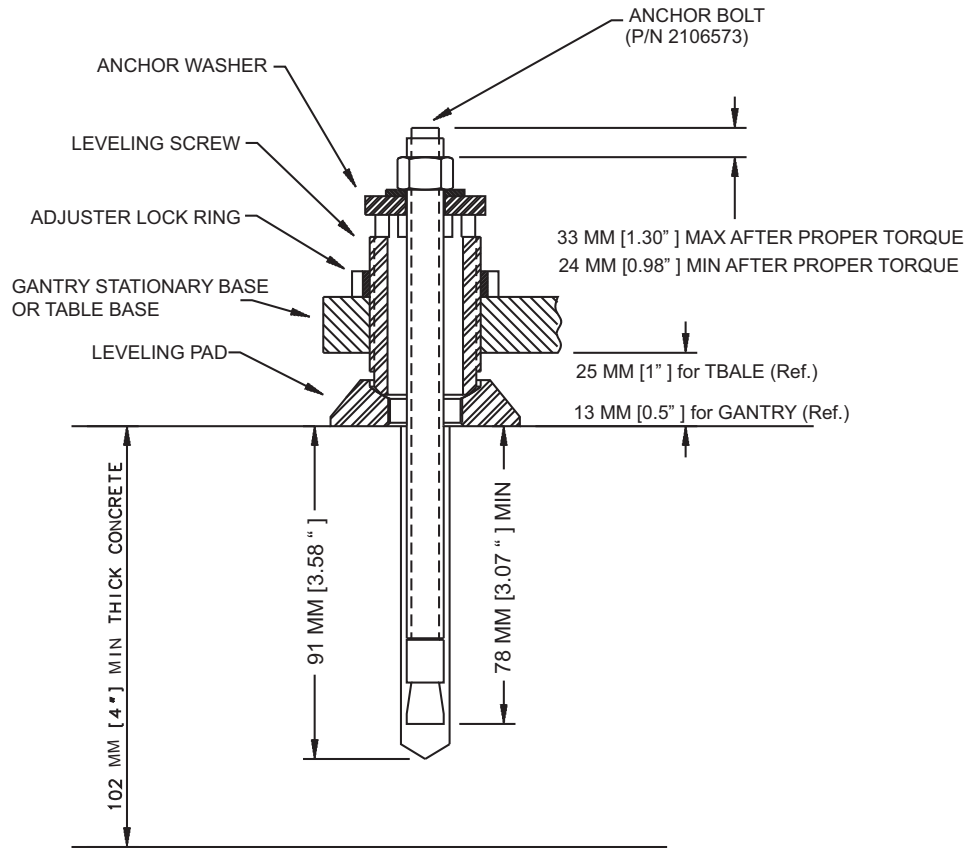


Figure 1-58 Gantry and Table Anchor Assembly with 8-inch Anchor (P/N 2106573)

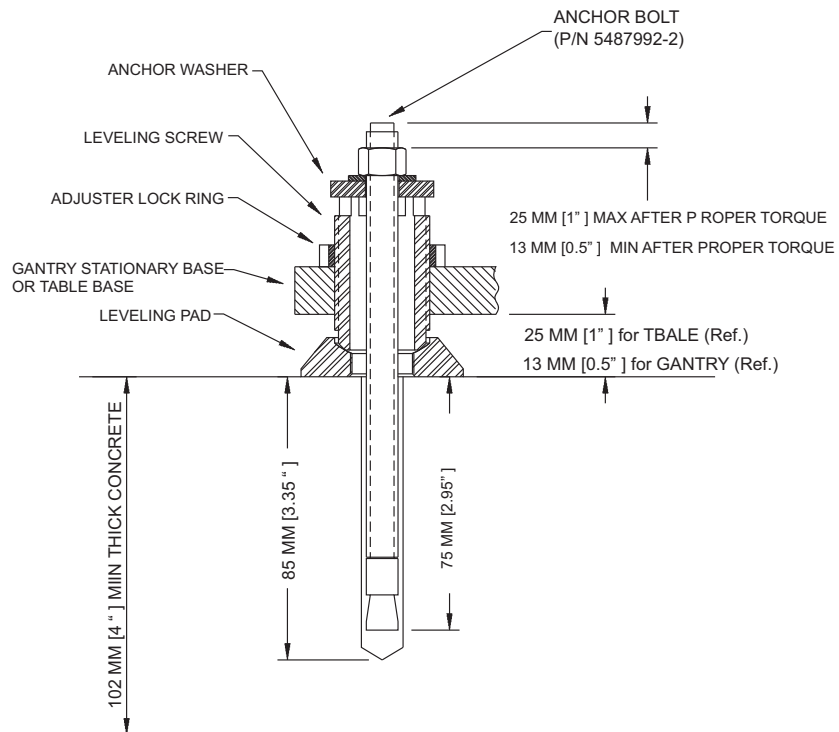


Figure 1-59 Gantry and Table Anchor Assembly with 7-inch Anchor (P/N 5487992-2)

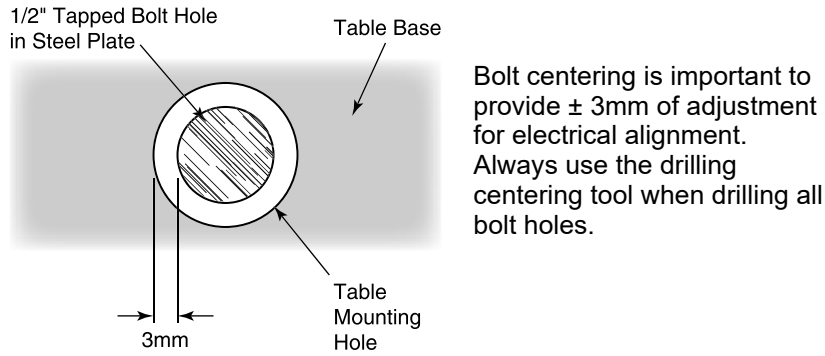


Figure 1-60 Center tapped holes under mounting holes in table base

11.8 Install the Anchors (For Lite Table)

Recommended - Use "Hilti Kwik-Bolt 3" anchors P/N 2106573-3 (12.7 mm (1/2") dia. by 140 mm (5-1/2") long) as shipped with the system for this procedure.

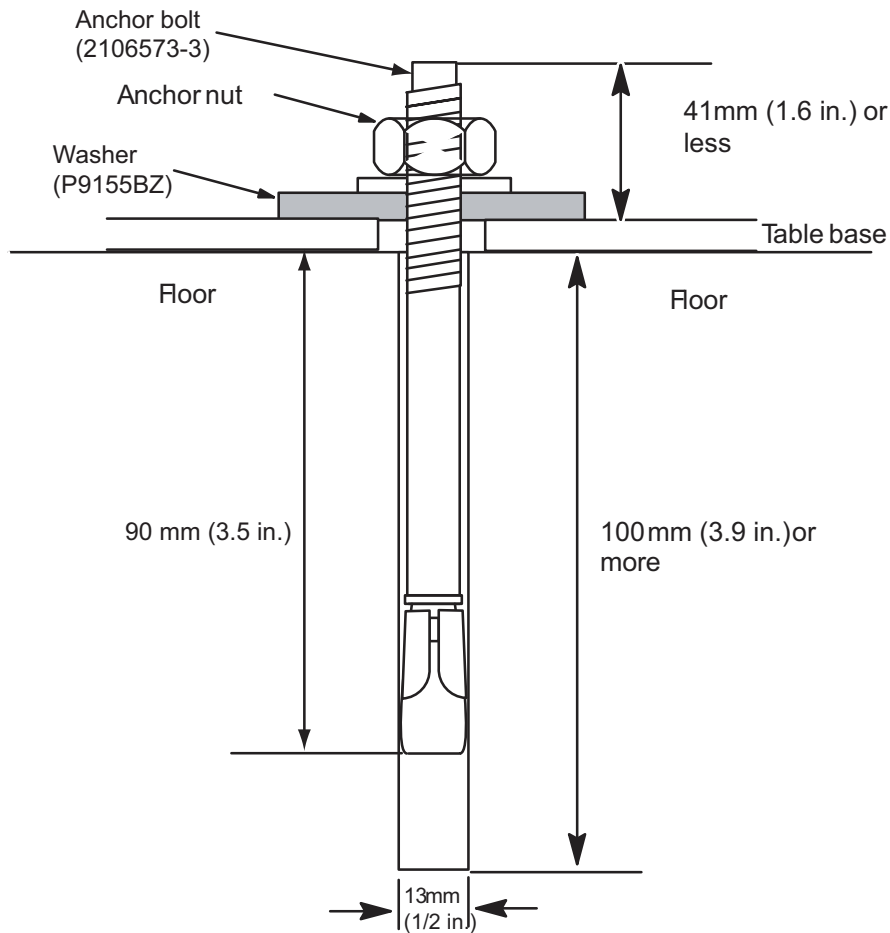


Figure 1-61 Lite Table Anchor Assembly

- 1.) Remove the alignment tool and repack the install kit.
- 2.) Assemble the anchors before you install them. Refer to [Figure 1-61](#).

- a.) Remove the nut and washer from the anchor.
 - b.) Add a ¼" thick washer (PN P9155BZ) under the regular anchor washer.
 - c.) Reassemble the anchor washer and nut and position nut so top is flush with threads of anchor.
- 3.) Adjust all anchor bolts until tight.

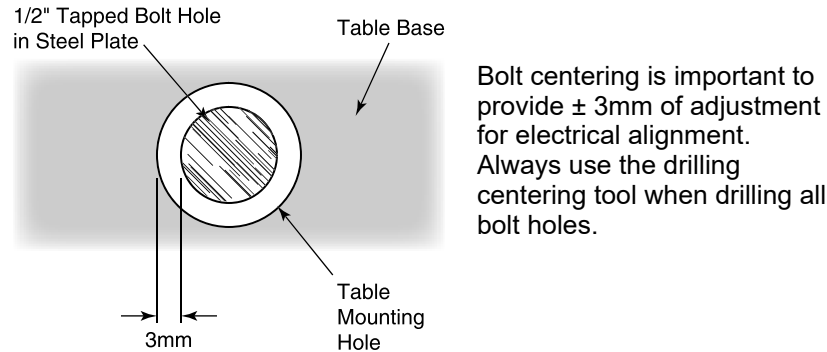


Figure 1-62 Center tapped holes under mounting holes in table base

11.9 Alignment Recheck

Note: Alignment is critical. Recheck carefully.

- 1.) Turn on the alignment tool and recheck alignments. The table alignment must be the same as in [9.3.6 Level and Center the Table to the Gantry, on page 60](#). If re-leveling is required, repeat this procedure. Using the bubble levels, make adjustments as required to maintain required alignment.
- 2.) Once alignment has been verified, torque all mounting bolts. Tighten the location #1 through #7 anchors and torque to:
 - **Gantry and GT1700V Table:**
 - 75 N-m (55 ft.-lb.) for 8-inch Anchor (P/N 2106573)
 - 54 N-m (40 ft.-lb.) for 7-inch Anchor (P/N 5487992-2)
 - **Lite Table:**
 - Initially torque at 50 N-m (37 t.-lb.), then loosen until approximately 5 N-m (3.7 ft.-lb.)
- 3.) Remove the laser tools.
- 4.) Reinstall all the removed table panels and hardware.
- 5.) Reinstall the gantry rear cover.

Note: If you cannot replace the lower table cover because the floor interferes, adjust all of the table and gantry levelers by half-turn increments to raise the table/gantry until the lower table covers clear the floor. Then return to the alignment sections to level the gantry, level the table, and tighten the locking rings, respectively.

11.10 Removing Table Shipping Dollies

11.10.1 Time and Personnel

(FE or mechanical supplier)

Required Persons	Preliminary Reqs	Procedure	Finalization
1 Electrician		20 min. labor on-site	

11.10.2 Tools and Test Equipment

- Standard Installation Tools Kit

11.10.3 Preparation

- All table mechanical alignment procedures are completed.
- The table is on the floor with at least one anchor in place.

11.10.4 Procedure

Refer to [Figure 1-63](#) for the location of items in the table dolly.

- 1.) Remove the two, long side (stabilizer) rails using the quick disconnect pins. There is one pin on each end of the bar.
- 2.) Carefully slide the bar out and place the bars on the side, out of the traffic area.

Note: The table should be resting on the floor. You may need to lower or raise the dolly to remove the dolly ends.

- 3.) Using the quick release pins, remove each end of the dolly.
- 4.) Slide the dolly off of the long attachment bar on each side.
- 5.) Using the quick release pins, remove the two long attachment bars that are attached to the front and rear table attachment points. Place the bars on the side, out of the traffic area.
- 6.) Use the 19 mm wrench to remove the bolts on each side of the smaller front table attachment bracket. Remove the bracket.
- 7.) Use the 19 mm wrench to remove the bolts on each side of the larger front table attachment bracket and transporter base. Remove the bracket.
- 8.) Reassemble the dolly for transportation.

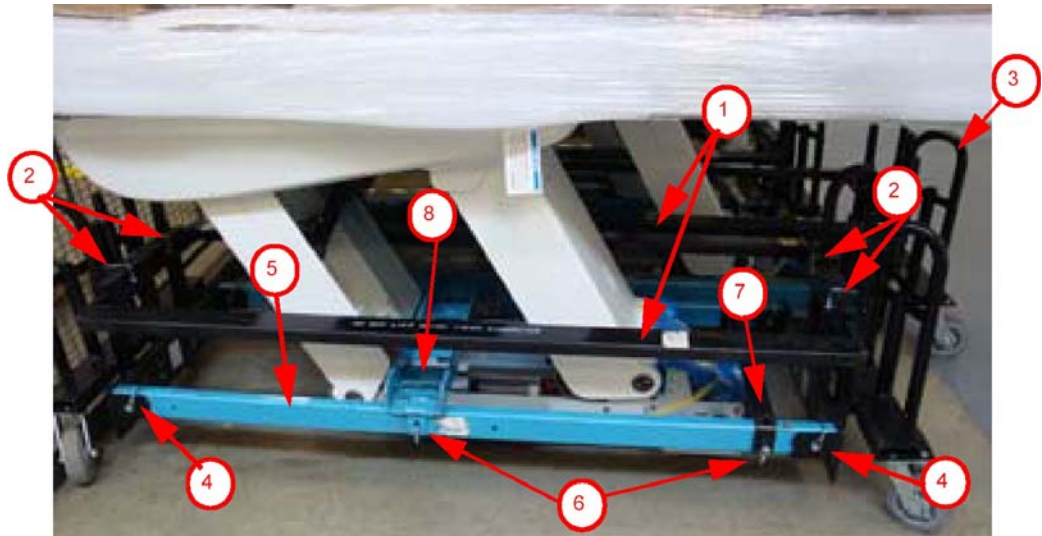


Figure 1-63 Table Shipping Dollies

Item	Description
1	Side Rails (two rails, black, one each side)
2	Quick Release Pins (for side rails, two on each side)
3	Dolly Ends (two, one each end)
4	Quick Release Pins (for dolly ends, two each side)
5	Table Dolly Lifting Tube (two, blue, one each side)
6	Quick Release Pins (for dolly lifting tube, two each side)
7	Front Attachment Bar (black, one; 19 mm table base bolt located under the bar, not shown)
8	Back Attachment Bar (blue, one; see Figure 1-63)
9	Table Base Bolt (see Figure 1-63)

Table 1-7 Description of Table Shipping Dollies



Figure 1-64 Close-up of table base connection

Section 12.0 Rear Entry Cable Box

A rear entry cable box (B7850RC) is used when the cables to the gantry cannot be brought up inside the gantry base. The box is not supplied with the system and must be ordered separately.

- 1.) Attach the rear entry cable box frame to the gantry base using four (4) screws that are shipped with the kit. See [Figure 1-65](#). The assembly can be made to fit floor entrance conduit or surface floor duct.

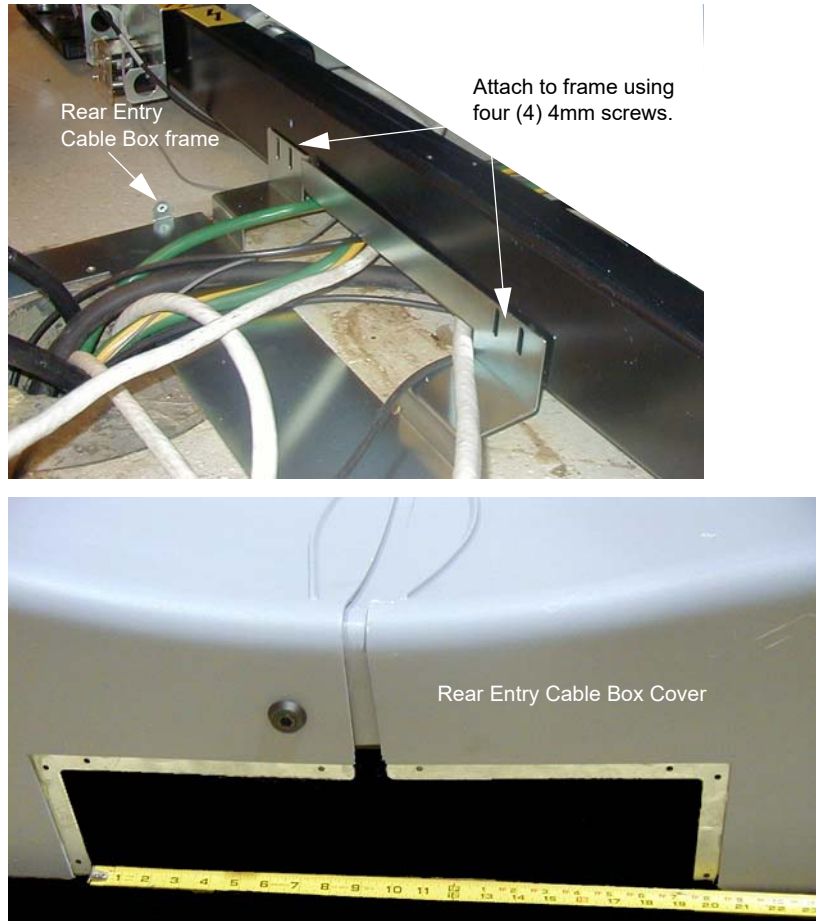


Figure 1-65 Rear Entry Cable Box

- 2.) There are three pairs of spacers shipped with this cover. Select the pair that is most appropriate for this site, based on the hardware.
 - Solid metal
 - Precut L-shaped metal
 - Solid plastic - Can be cut

12.1 Rear Entry with Surface Floor Duct

An OSHA ramp is required. The ramp must have 1' run of slope for each 1" rise in height.



Figure 1-66 OSHA Ramp Example

Section 13.0 Install Table Footswitch Assembly (GT1700V)

13.1 Time and Personnel

Required Persons	Preliminary Reqs	Procedure	Finalization
1 (FE or mechanical supplier)		1.0 hour labor on-site	

13.2 Tools and Test Equipment

- Standard Install Tool Kit

13.3 Procedure

After table positioning is completed and the anchors are installed, install the footswitch assembly as shown in [Figure 1-67](#).

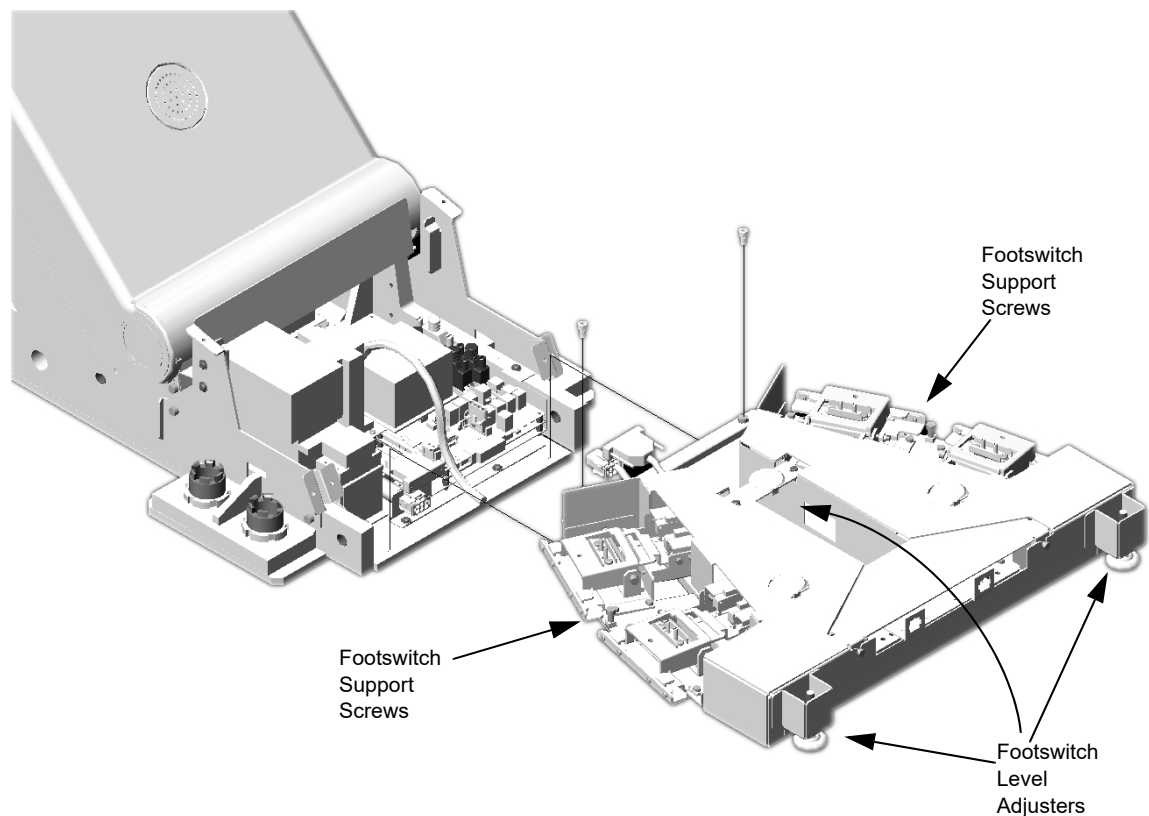


Figure 1-67 Footswitch Assembly Installation

- 1.) Pop off foot pedal screw cover tabs.
- 2.) Remove foot switch covers.
- 3.) Remove 3 Phillips screws that secure the assembly cover.

- 4.) Remove the footswitch assembly cover.
- 5.) Using two (2) M6 bolts, attach the footswitch assembly to the table base.

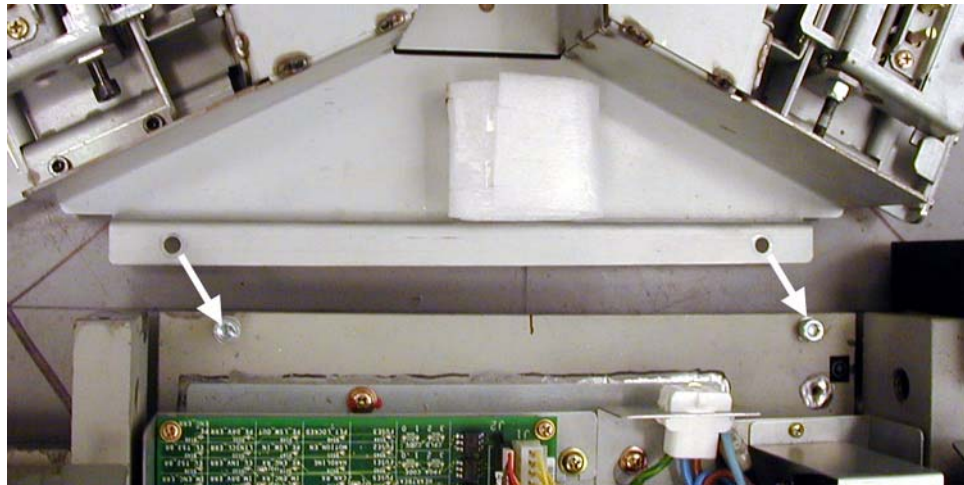
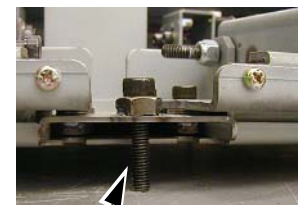
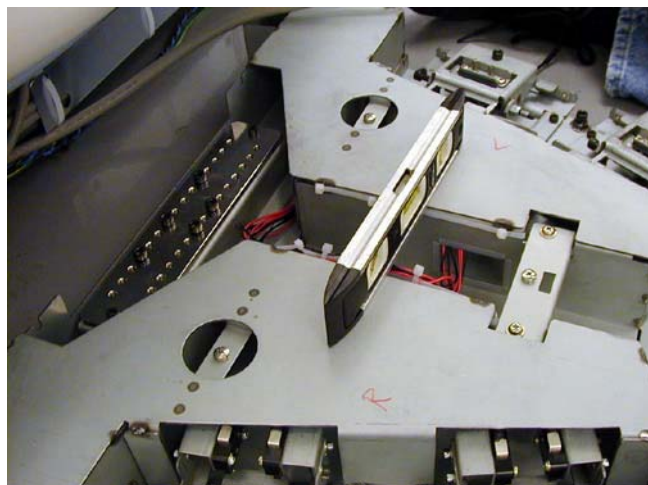
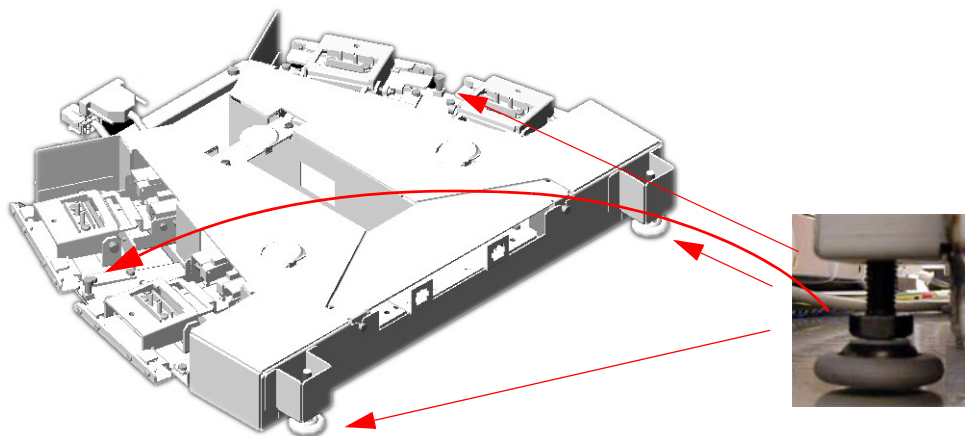


Figure 1-68 Attach Footswitch

- 6.) Level the footswitch assembly using the three (3) level adjusters. Two are on the gantry side and one is in the middle. Use a 9 in. level to check the levelness in all directions.



Footswitch support screw

Figure 1-69 Level Footswitch

- 7.) Cut the tie-wraps from around the cables in the gantry base and route the power cables from the gantry as shown in [Figure 1-70](#).

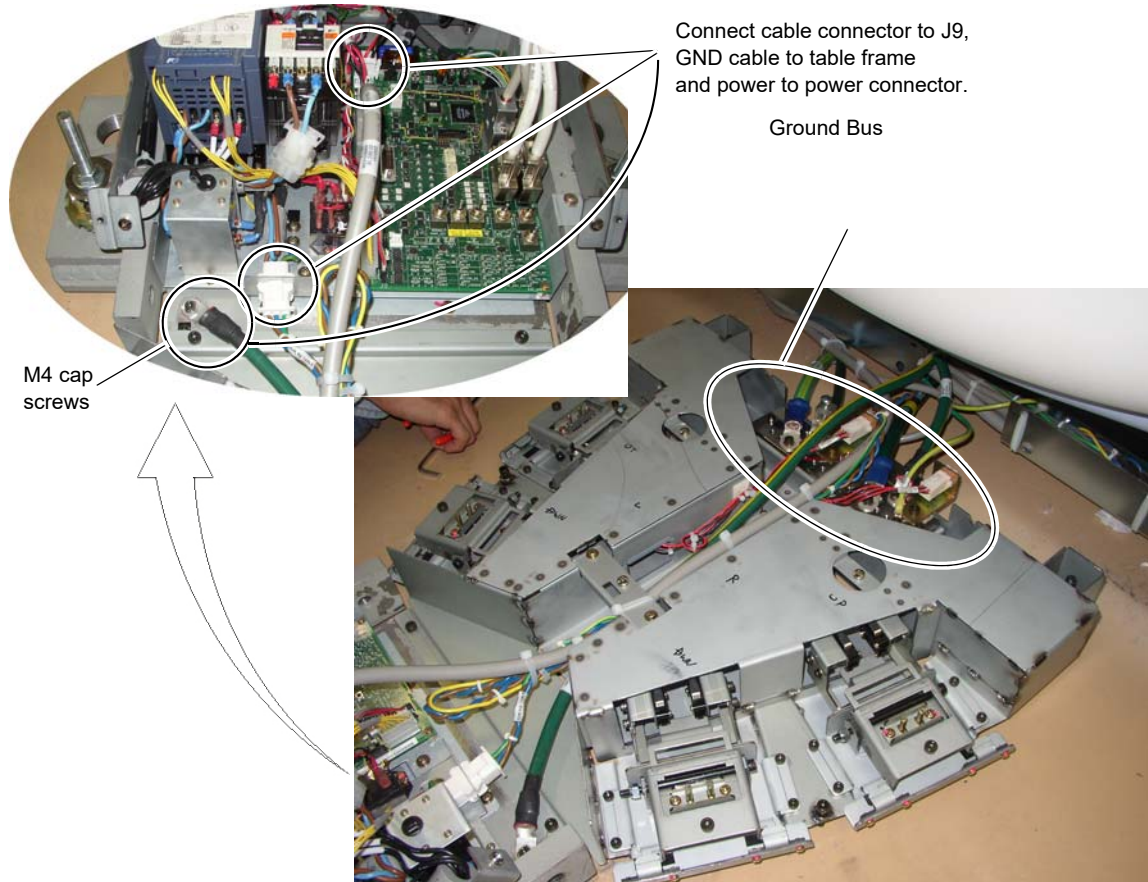


Figure 1-70 Footswitch Assembly Cable Wiring

- 8.) Connect the ground bus connector plate.

Note: Additional M6 Hex-screws may be required to connect grounds.

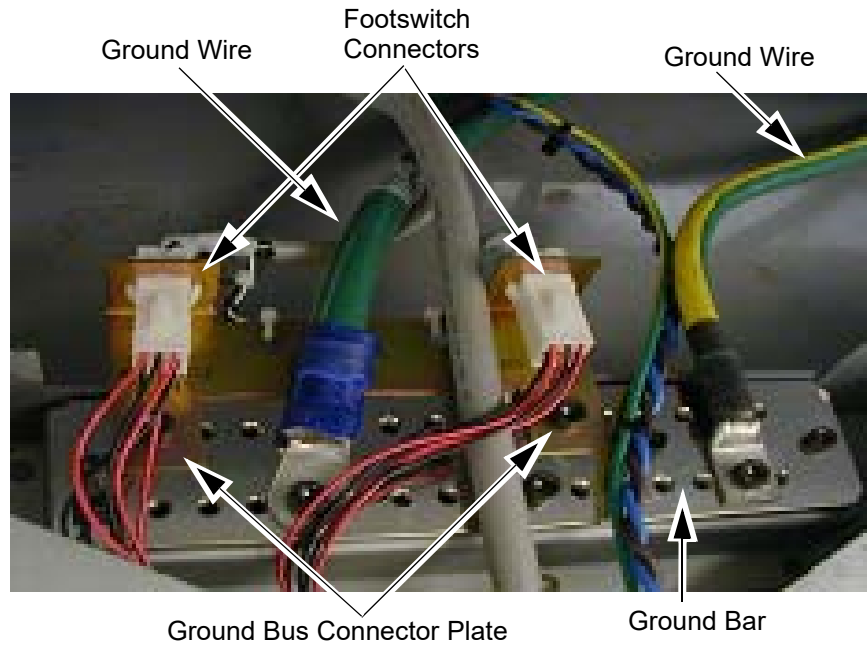


Figure 1-71 Footswitch Ground/Bus Bar

- 9.) Install the footswitch pedal bracket onto the installed ground bus bar.
 Connect the ground wires (not all shown in [Figure 1-71](#)) to the installed ground bus:
 Table#2
 Gantry#1/0 and #10 and 2-#8 (Optional)
 Console#2
 PDU#1/0
- 10.) Torque per [Table 1-8](#).

Wire Size AWG	Driver	Bolt/Hex
#14 - 8	1.67 ft-lb (2.3 N-m)	6.25 (8.5 N-m)
#6 - 4	3.0 ft-lb (4.1 N-m)	12.5 (17 N-m)
#3 - 1		21 ft-lb (28.5 N-m)
#0 - 2/0		29 ft-lb (39.3 N-m)

Table 1-8 Ground Buss Bar Torque Values

- 11.) Install all footswitch covers after work is completed. See Section [1.8 Install Gantry Base Covers](#), on page 168.

Section 14.0 Install Table Footswitch Assembly (Lite Table)

14.1 Time and Personnel

Required Persons	Preliminary Reqs	Procedure	Finalization
1 (FE or mechanical supplier)		1.0 hour labor on-site	

14.2 Tools and Test Equipment

- Standard Install Tool Kit

14.3 Procedure

Install the table foot-switch assembly as shown in [Figure 1-72](#), along with filler strip.

- 1.) Connect foot-switch cables.

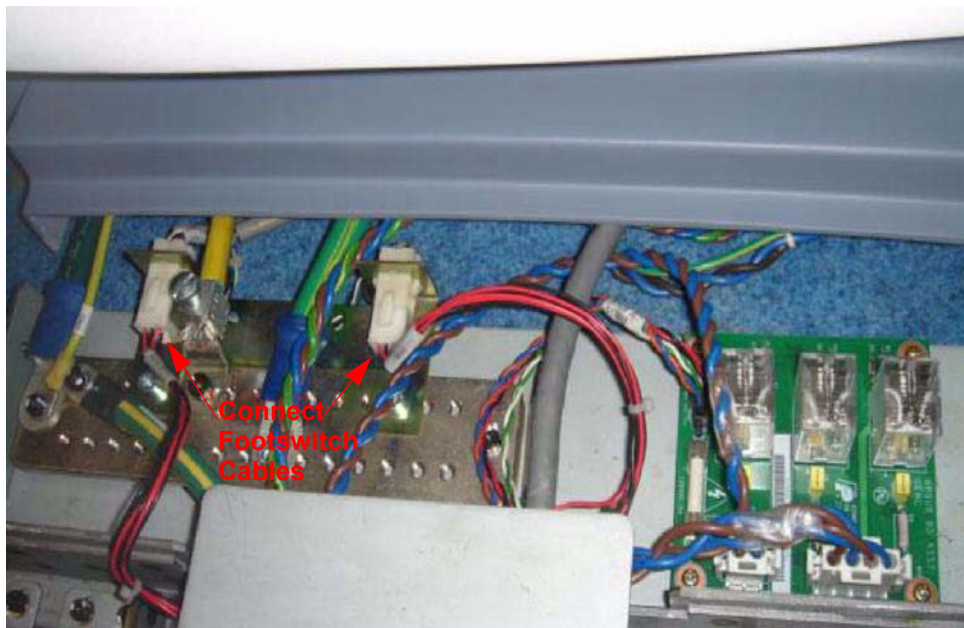


Figure 1-72 Install Table Foot-switch

- 2.) Install front bottom cover and footswitch pedals.



Figure 1-73 Install Front Bottom Cover



Figure 1-74 Install Footswitch Pedals

Section 15.0 Remove Gantry Tilt Bracket

15.1 Time and Personnel

Required Persons	Preliminary Reqs	Procedure	Finalization
1 (FE or mechanical supplier)		Labor on-site	

15.2 Tools and Test Equipment

- 10 mm Hex wrench
- 14 mm Hex wrench

15.3 Procedure

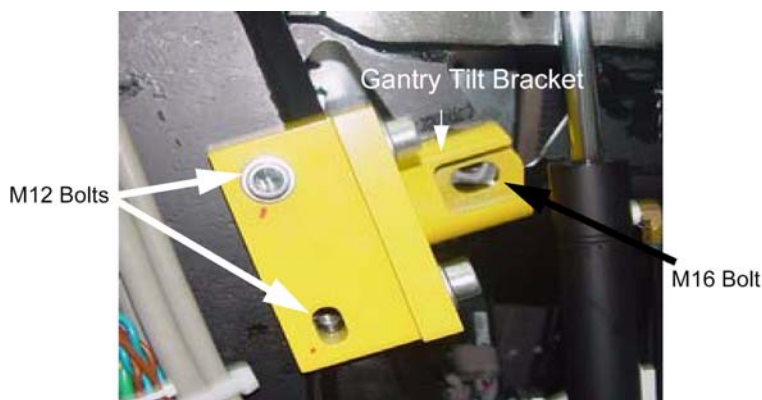


Figure 1-75 Gantry Tilt Bracket Removal

- 1.) Refer to [Figure 1-75](#). Remove the M12 bolts using a 10 mm Hex wrench.
- 2.) Loosen the M16 bolt 1-2 turns and check the Gantry tilt bracket, it should be loose to the touch. If loose continue with step 4.

CAUTION



Potential for personal injury.

If tilt bracket is not loose, stop and put the M12 bolts back in and tighten tilt bracket back in place. If there is a load on the tilt bracket, removal may cause the gantry to suddenly tilt all the way back due to a possible lack of hydraulic pressure.

- 3.) Check the hydraulic connections for leaks or lack of fluid. You will have to wait until the system can be energized to use the tilt controls to relieve the load on the tilt bracket prior to removal. Do not use force to remove the bracket.
- 4.) If the bracket feels loose, remove the M16 bolt using a 16 mm Hex wrench.
- 5.) Remove the bracket.
- 6.) Close the gantry covers and reinstall the scan window.
- 7.) Store brackets in the gantry base.

Section 16.0 Position the Power Distribution Unit



WARNING LOCKOUT/TAGOUT IS REQUIRED BEFORE PERFORMING THIS TASK. USE THE SUPPLIED LOTO KIT.

ALL INSTALLATION WORK WITHIN THIS SECTION ON THE POWER DISTRIBUTION UNIT SHOULD BE COMPLETED BY A LICENSED ELECTRICIAN ONLY.

Note: Connecting the primary incoming power is performed by the customer’s electrical contractor. The electrician needs to provide a reducing bushing to attach the flexible conduit to the PDU

16.1 Time and Personnel

Required Persons	Preliminary Reqs	Procedure	Finalization
1 Customer Electrician		Labor on-site	

16.2 Tools and Test Equipment

Hex wrench set

16.3 Procedure

- 1.) Roll the PDU into position on its permanently mounted casters. Leave at least 15.5 cm (6 in.) between the PDU and back wall to allow cooling air to circulate.

Connection or Wall Box	AWG #	Connection From	Connection To PDU	Installed & Checked
TS1	Note 1	PDB-A	TS1-1	
	Note 1	PDB-B	TS1-2	
	Note 1	PDB-C	TS1-3	
	#1/0	GND	N/G	
(Do NOT connect anything to neutral point.)				

Note 1 : Refer to Pre-Installation manual.

Table 1-9 Contractor Connections

Wire Size AWG	Driver	Bolt/Hex
#18 - 16	1.67 ft-lb (2.3 N-m)	6.25 (8.5 N-m)
#14 - 8	1.67 ft-lb (2.3 N-m)	6.25 (8.5 N-m)
#6 - 4	3.0 ft-lb (4.1 N-m)	12.5 (17 N-m)
#0 - 2/0	N/A	29 ft-lb (39.3 N-m)

Table 1-10 Power Wire Torque Values

- 2.) Run the main input power conductors and ground through flexible metal conduit (attached between the PDU chassis and room duct-work) so you can move the PDU away from the wall during service.



Figure 1-76 Flexible Conduit for PDU Power

- 3.) Locate the hole cover plate in Box 1 and attach the flexible metal conduit to the PDU.
- 4.) If present, remove the TS1 panel front cover.
- 5.) Strip the wires to fit securely on the power block.
- 6.) Observe incoming phases (L1, L2, and L3) and insert bare leads into power block.
- 7.) Insert vault ground into PDU vault ground lug.
- 8.) Tighten all fasteners securely and replace the TS3 front panel.

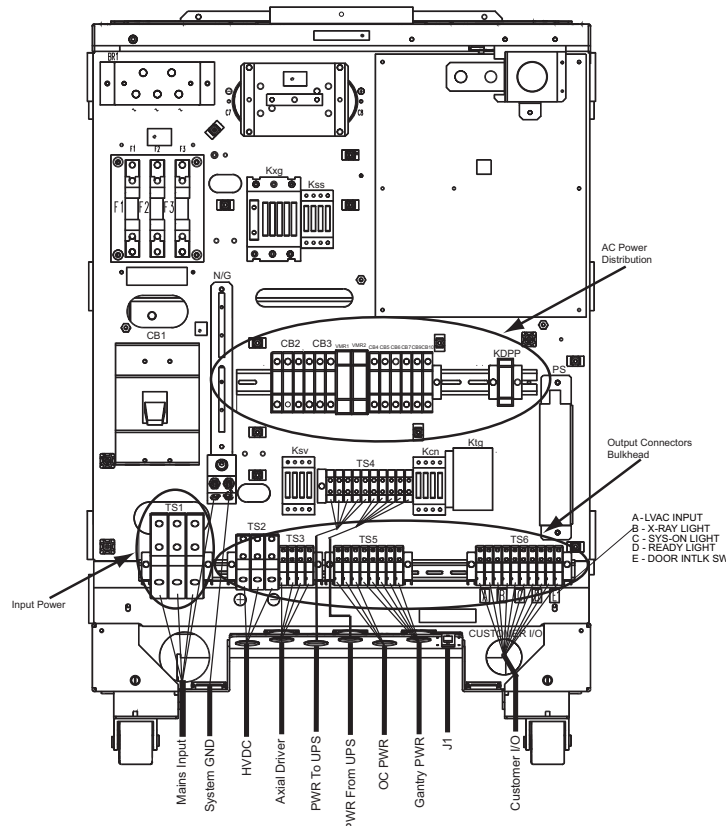


Figure 1-77 PDU Area Locations

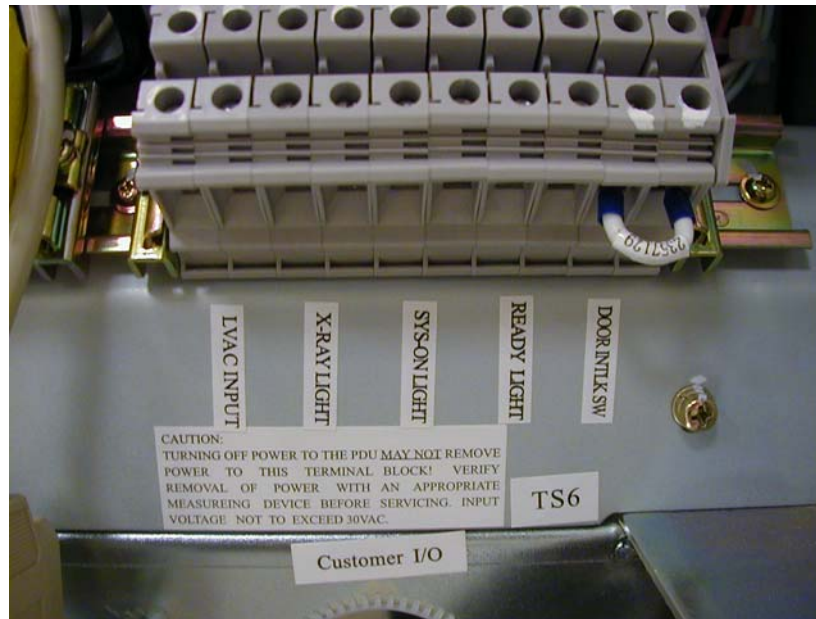


Figure 1-78 PDU Power Connections



WARNING



WORK WITH THE ELECTRICAL CONTRACTOR TO BE SURE EXTERNAL POWER SOURCE IS TURNED OFF.

CONNECTION OR WALL BOX	AWG #	CONNECTION FROM	CONNECTION TO PDU	INSTALLED AND CHECKED
A1	*1	Load - T1	TS-1 L1	
	*1	Load - T2	TS-1 L2	
	*1	Load - T3	TS-1 L3	
	#1/0	GND	TS-1 GND (Do NOT connect anything to neutral point.)	
WL (Warning light)	#14	LV Source -1	TS6 1	
	#14	LV Source -2	TS6 2	
	#14	X-Ray ON Light -1	TS6 3	
	#14	X-Ray ON Light -2	TS6 4	
	#14	Sys-ON Light -1	TS6 5	
	#14	Sys-ON Light -2	TS6 6	
	#14	Ready Light -1	TS6 7	
	#14	Ready Light -2	TS6 8	
DS (Scan Room Door Switch)	#14	Door SW-1	TS6 9	
	#14	Door SW-2	TS6 10	

***1:** Sub-feeder wire size depends on system input voltage. Refer to Ch. 12 - Power Requirements in Pre-Installation manual.

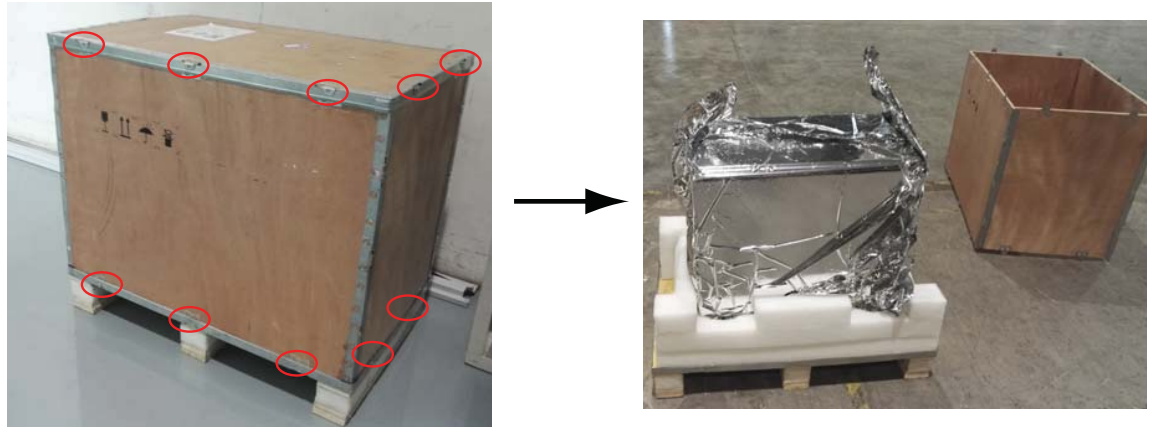
Table 1-11 Contractor PDU Connections

Section 17.0 Install Operator Console

17.1 Unpack OpenOC Console

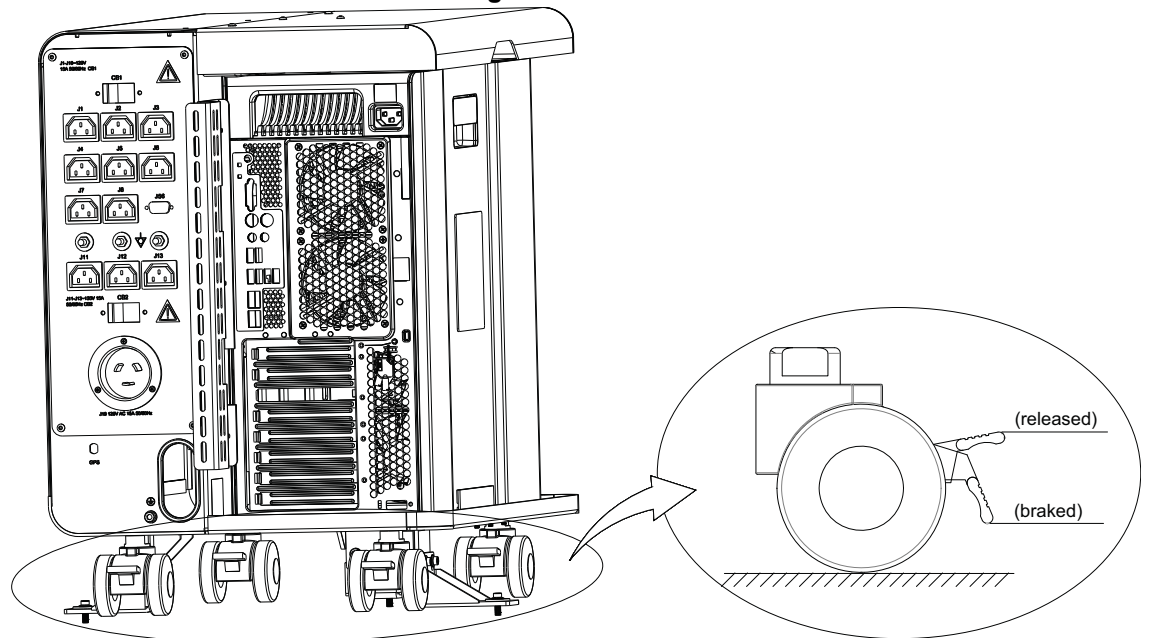
- 1.) Unpack console packaging.
 - a.) Prize up buckles by using screwdriver and remove the packaging covers.

Figure 1-79 Console Packaging Removal



- b.) Remove all packaging and discard per local requirement
- 2.) Move console to installation location.
- 3.) Adjust console position, and then pedal four brakes to prevent console from sliding.

Figure 1-80 Brake



17.2 Unpack NIO Console

- 1.) Remove all items from the console.
- 2.) Remove all packing materials and discard.
- 3.) Place the step-board under the front edge of the skid and step on it to raise the front edge of the skid as in [Figure 1-81](#).

Figure 1-81 Step-board used to raise front edge of skid



- 4.) Remove the two front cushions from the bottom of the skid. Refer to [Figure 1-82](#)

Figure 1-82 Cushion on bottom of skid

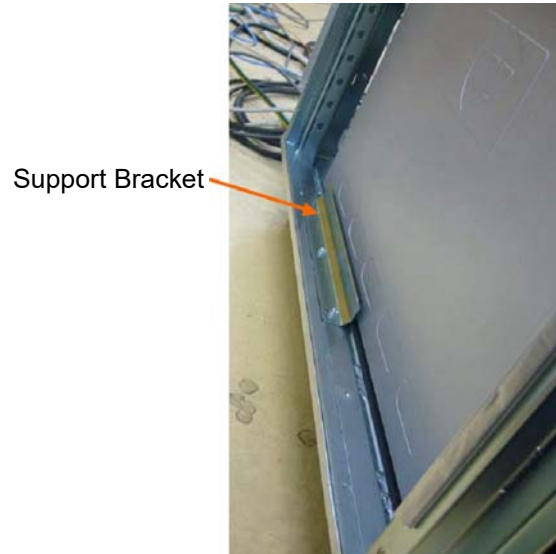


- 5.) Lift up on the strap on the front of the step-board ([Figure 1-81](#)) to lower the skid. Remove the step-board.
- 6.) Ensure the console stabilizers are in line with the notched portion at the front of the skid. This will allow enough clearance to smoothly roll the console down the ramps.
- 7.) Move console to installation location.

17.2.1 Remove the HostPC support Bracket

- 1.) Remove the Host PC Support Bracket from left side of Console (refer to [Figure 1-83](#)).

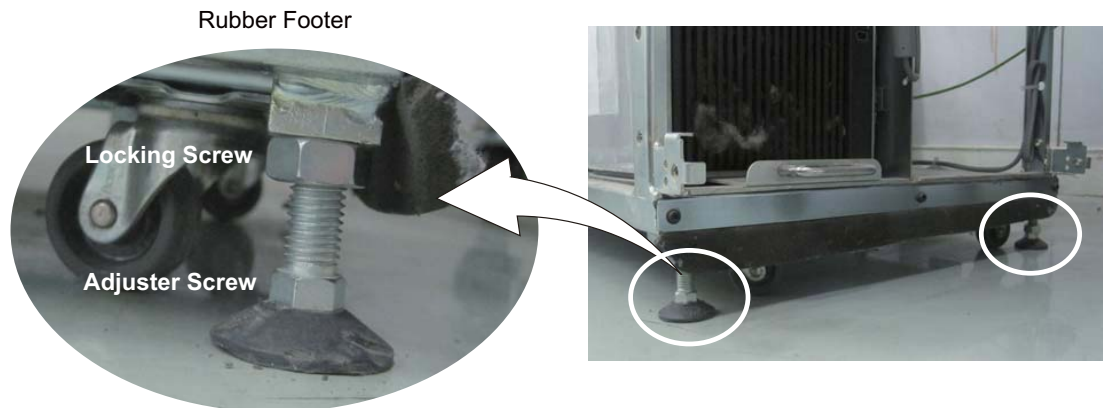
Figure 1-83 Host PC Support Bracket



17.2.2 Footer Adjustment

- 1.) Place the console at the operator room.
- 2.) Adjust two rubber footer to prevent console from sliding.

Figure 1-84 Rubber Footer Adjustment



17.3 Install Operation Table

17.3.1 Install Aurora SWS table

- 1.) If your system has the SWS table, assemble SWS table.
Refer to [Appendix C](#) for details of SWS Table assembly.
- 2.) Place the SWS table at one side of the console.

17.4 Peripherals Placement

- 1.) Place keyboard, GSCB
- 2.) Locate and unpack the Media tower.
- 3.) Place the Media tower on the console desk.

Section 18.0 Seismic Mounting

Before proceeding with seismic mounting for any of the components in this section, be sure to allow sufficient space to unbolt and move the component from its mounted location for service.

- You may need to remove all four mounting bolts.
- If removing the component requires lifting, use an appropriate-sized pry bar to lift each corner of the component.
- Two installers may be required to safely complete this task.
- 5/8 in. anchor for IBC 2007 standards or as provided in the seismic kit.

1 - Pos. Subsystems

18.1 Time and Personnel

Required Persons	Preliminary Reqs	Procedure	Finalization
1 (FE or mechanical supplier)		Labor on-site	

18.2 Procedures

18.2.1 Console

If site specifications require seismic mounting, use M8 or 3/8" anchor bolts to mount the brackets to the floor. Refer to [Figure 1-85](#) for hole placement. The console seismic brackets are shipped with the console.

Note: If you use the front anchor holes as alternative anchor location, use the Drop-in type anchor.

Unit: mm (in)

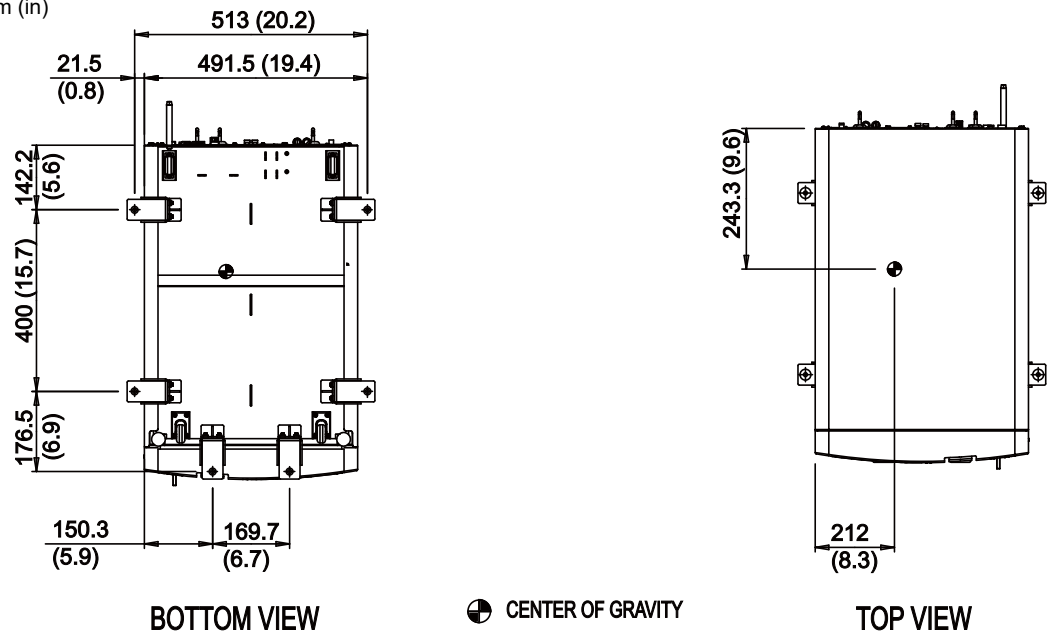


Figure 1-85 Seismic NIO Console Mounting Hole Locations

Unit: mm (in)

 Center of Gravity

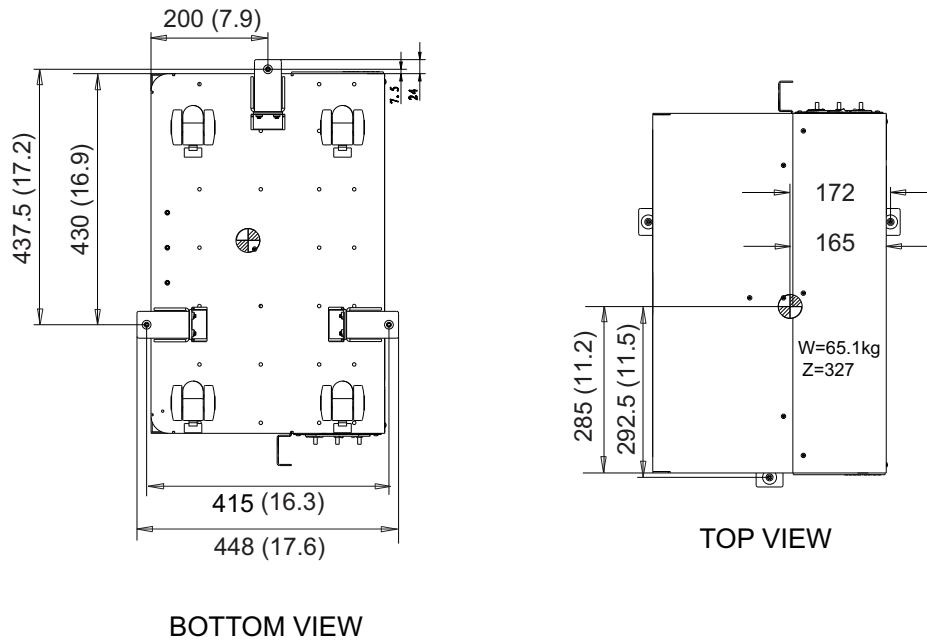
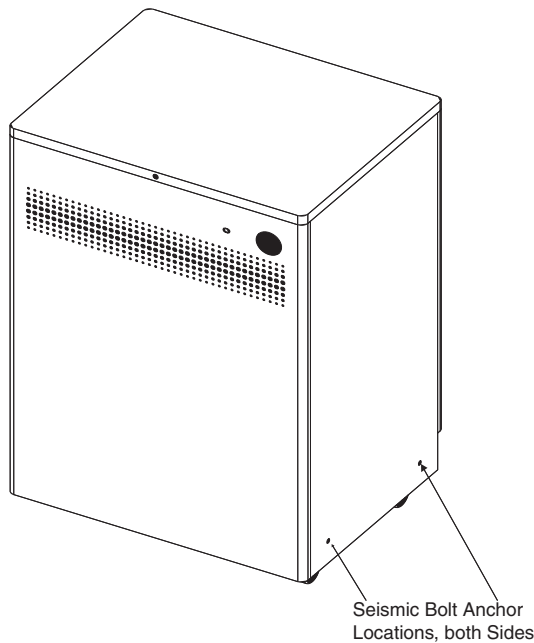


Figure 1-86 Seismic OpenOC Console Mounting Hole Locations

18.2.2 Power Distribution Unit

CAUTION The PDU is very heavy and may present a crush hazard if proper precaution and tools are not used.

If site specifications require seismic mounting, use 5/8 in. (15mm) bolts, and the seismic brackets and anchors that shipped with the NGPDU. Refer to [Figure 1-87](#) for mounting hole locations, and mount the PDU so it can be easily removed for service.



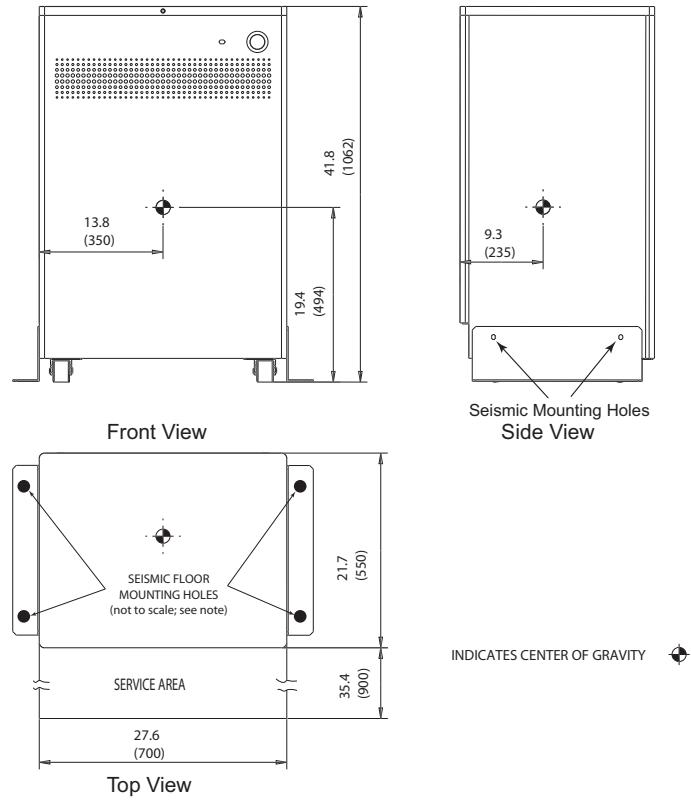


Figure 1-87 Seismic PDU Mounting Hole Locations

Chapter 2

Power, Ground & Interconnect Cables



NOTICE Potential for Data Loss and/or Equipment Damage

To prevent potential data loss and equipment damage, please do the following:

- Record data collected from procedures in this chapter into Form F4879 when directed.
- Only use the Installation manual that arrives with your system for installation. Any other revisions of this manual may not exactly match your system.

Section 1.0 Introduction

Site use of conduit, floor duct, wall duct, or a raised computer floor, as well as the individual component layout determines the system cable sequence. If your site has floor or wall ducts that will interfere with placement of the table/gantry, it may be important to have the movers unload the cable boxes (8 & 9) first and run those cables while others unload the subsystems.

- Try to run the system cables after the contractor completes the contractor supplied wiring.
- All ground wires and other contractor wiring should be complete to the point of equipment placement.



NOTICE Potential for Equipment Damage

1.1 Cable Storage

Do not store excess cable in the bottom of the PDU or Gantry.

Do not store excess cable behind or under the installed components (table, PDU, gantry or console). Check with the site electrical contractor, before hiding excess in conduits or cable ducts.

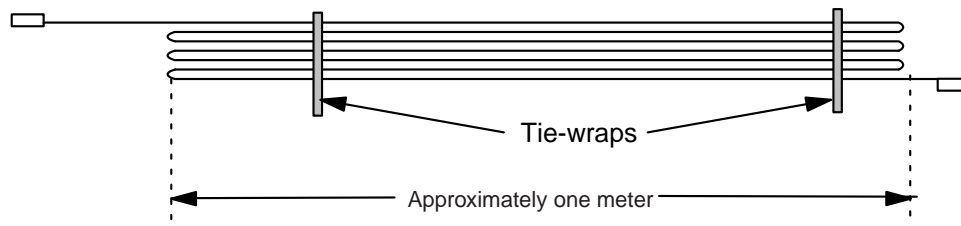


Figure 2-1 Excess Cable Storage Configuration

- Keep signal and control cables away from power cables and power wiring. When you lay cables in a raceway, locate the signal cables in a separate section of the raceway, or a separate conduit.
- Check all connections for tightness.
 - Use suitable tools and judgment.
 - Check all visible connections, especially ground connections.

- **Check for reasonable cable routing.**
 - Take into consideration necessary take-up distances for equipment maintenance, etc.
 - Try to complete as neat a job as possible.

1.2 System Component Identification

Identify all system cables by the system component designators listed in [Table 2-1](#). Each end of a system cable has a label, and may have a color near the connector, (refer to [Table 2-2](#)) to indicate the component and the jack identifier of the component. All cables are located on the lower right shelf of the lean cart.

DESIGNATOR	SYSTEM COMPONENT
CT2	Gantry
CT1	Patient Table
PDU	Power Distribution Unit
OC	Operator Console (Console Computer)
WL	X-Ray ON Warning Light
A1	Primary Power Disconnect
SEO	System Emergency OFF
DS	Door Interlock Switch
BBNC	Broad-Band Network Connection

Table 2-1 System Component Identifiers

1.3 Cable Color Identifiers

The ends of the cables may be marked with a piece of blue, yellow, red, or orange colored tape to help with the cable installation. [Table 2-2](#) lists the subcomponent, and corresponding color.

SUBCOMPONENT	COLOR
Gantry	Blue
Table	Yellow
PDU	Red
Console Computer	Orange

Table 2-2 Cable Color Identifiers

RUN NO.	DESCRIPTION	PART NUMBER	
		LONG CABLES (KIT P/N 5444556-2)	SHORT CABLES (KIT P/N 5444556)
1	Facility MDP to Room Disconnect (A1)	cust. supplied	cust. supplied
2	Room Disconnect (A1) to PDU	cust. supplied	cust. supplied
3	Room Disconnect (A1) to System E-Off	cust. supplied	cust. supplied

Table 2-3 System Interconnect Cables

RUN NO.	DESCRIPTION	PART NUMBER	
		LONG CABLES (KIT P/N 5444556-2)	SHORT CABLES (KIT P/N 5444556)
4	PDU to Room Warning Light(s)	cust. supplied	cust. supplied
5	PDU to Scan Room Door Switch	cust. supplied	cust. supplied
50	HVDC Power Cable - PDU to Gantry	2343529	2343529-2
51	HVAC Power Cable - PDU to Gantry	2343530	2343530-2
52	LVAC Power Cable - PDU to Gantry	2343528-3	2343528-4
53	LVAC Power Cable - PDU To Operator's Console	2343531	2343531-2
54	LVAC Power Cable - Gantry to Table	n/a	n/a
55	Ground, PDU to Raceway	2371450	2371450-2
56	Ground, Raceway to Console	2371450-3	2371450-4
60	LVAC Power Cable - PDU to Optional UPS	-	-
61	LVAC Power Cable - UPS Disconnect Panel to PDU	-	-
90	LVAC Power Cable - PDU to PET	-	-
100	Signal Cable - Gantry to PDU	5419992	5419992-2
101	Signal Cable - Gantry to Console	5419981	5419981-2
102	Signal Cable (Ethernet) - Gantry to Console	5454760-2	5454760
103	Data Cable (Fiber Optic) - Gantry to Console	5478856	5478856-2
104	Signal Cable - Gantry to Table	n/a	n/a
110	Signal Cable - UPS Control to Room Disconnect (A1)	-	-
111	Signal Cable - UPS Control to UPS Disconnect Panel	-	-

Table 2-3 System Interconnect Cables (Continued)

NOTICE



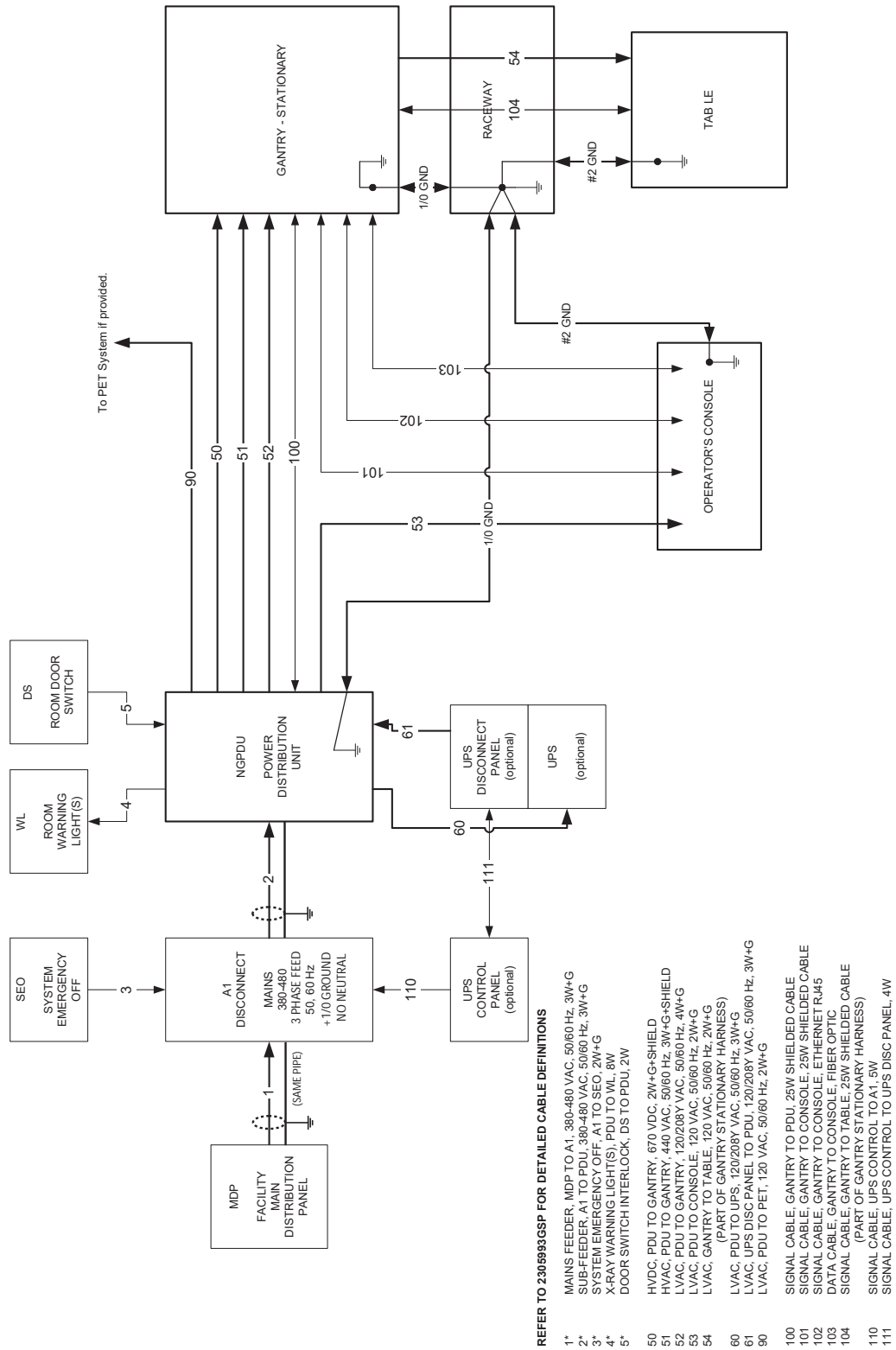
Shortening power cables is not allowed. The crimping tool and ferrules are not shipped with the system.

If longer or shorter cables are required, order the correct set.

Excess cables cannot be stored under or behind the PDU, gantry or console.

Section 2.0 System Interconnect Diagram

Figure 2-2 System Interconnect Diagram



Section 3.0 NIO Console Connections

3.1 GSCB, Keyboard & Mouse Installation

PART #	DESCRIPTION	CONNECT TO	QTY	LENGTH	
				INCHES	MM
5366514-2	USB EXTENSION CABLE	Keyboard	1	140.16 ± 1.18	3560 ± 30
5366514	USB EXTENSION CABLE	Mouse	1	118.11 ± 1.18	3000 ± 30
5332107-2	CABLE, DVI to D-SUB VIDEO CABLE	Monitor	1	118.11 ± 0.79	3000 ± 20
5315370	CABLE, USB TYPE A-B	PMT media Tower, DVD-RW/USB external HDD	2	78.74	2000
5408703	DP to DVI cable, 3 meter	Monitor	1	118.11 ± 1.97	3000 ± 50
5432953-2	Power Cable, Peripheral Tower to NIO AC Box	PMT Media Tower	1	120 ± 1.97	3050 ± 50
5432953-3	Power Cable, Display Monitor to NIO AC Box	Display Monitor	1	120 ± 1.97	3050 ± 50
5432953-4	Power Cable, Scan Monitor to NIO AC Box	Scan Monitor	1	120 ± 1.97	3050 ± 50

Table 2-4 GE Healthcare Supplied NIO64 Console Cables

- 1.) Route the keyboard cable under the GSCB, as shown in [Figure 2-3](#).



Figure 2-3 GSCB connected to the keyboard

NOTICE



Potential for equipment damage

Never connect a mouse or keyboard with the host computer powered “ON”. Doing so can destroy components within the host computer.

- 2.) Route the keyboard and mouse cables to NIO64 console.

NOTICE

NIO64 has hong cable kit option (5456816).

Refer to the Instruction, NIO Console Long Cable Kit Installation Manual, Service Methods - >Installation -> Option-> NIO Console Long Cable Kit Installation (Dir 5456816-1EN)

- 3.) Select the local language overlay from the keyboard collector (5431062-1-XX) for your system.
 - Select keyboard overlay from keyboard collector (5324605-XX) to attach. (See [Figure 2-4](#))

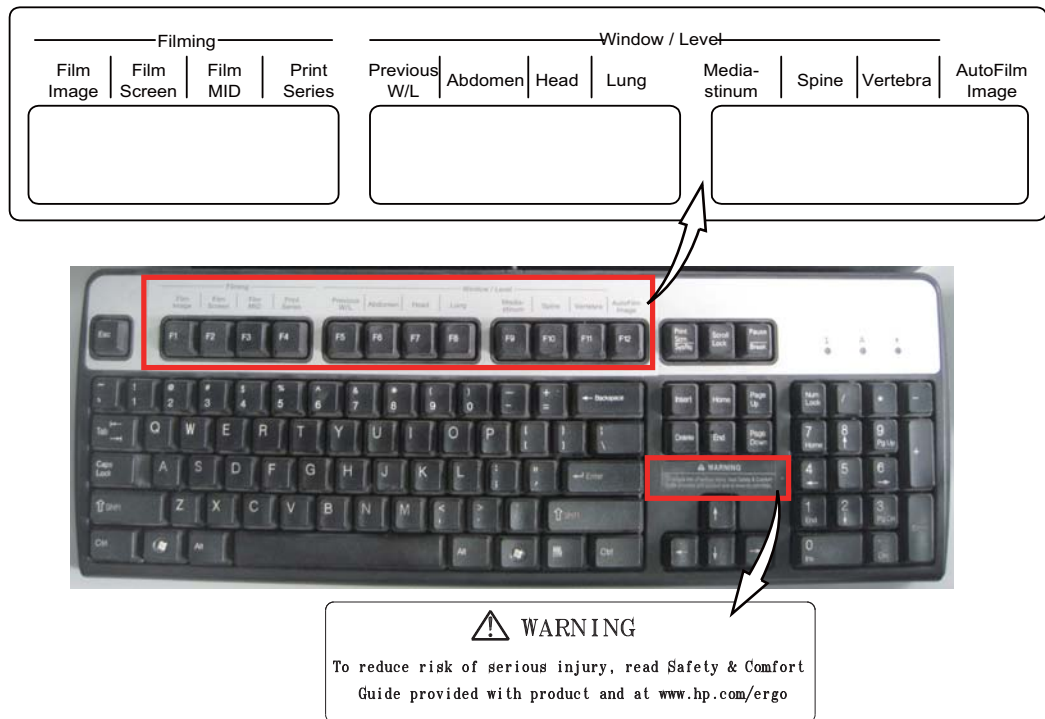


Figure 2-4 Keyboard with the English film and Warning Label Installed

- Select the GSCB overlay (with both Tilt and E-Reset, P/N is 5401237-XXX) install the proper overlay with the appropriate language for the system.

Verify that none of the buttons get caught and stuck under the overlay. Pay close attention to the prescribed tilt button on systems with the tilt feature.

Note: X-ray ON sound can be turned off / on using the switch on GSCB bottom if customer does not like it and if local regulation does not require X-ray ON sound. Detail information refer to **Service Methods->Troubleshooting->Console-> GSCB Troubleshooting.**

- 4.) The keyboard should attach to the GSCB using the supplied Velcro strip and fit snugly against the GSCB when finished, as shown in [Figure 2-3](#).
- 5.) Route the GSCB cable and connect connectors according to [Figure 2-5](#) and [Table 2-5](#)

Note: The USB cable of GSCB is reserved, please tie it with tie-wrap.

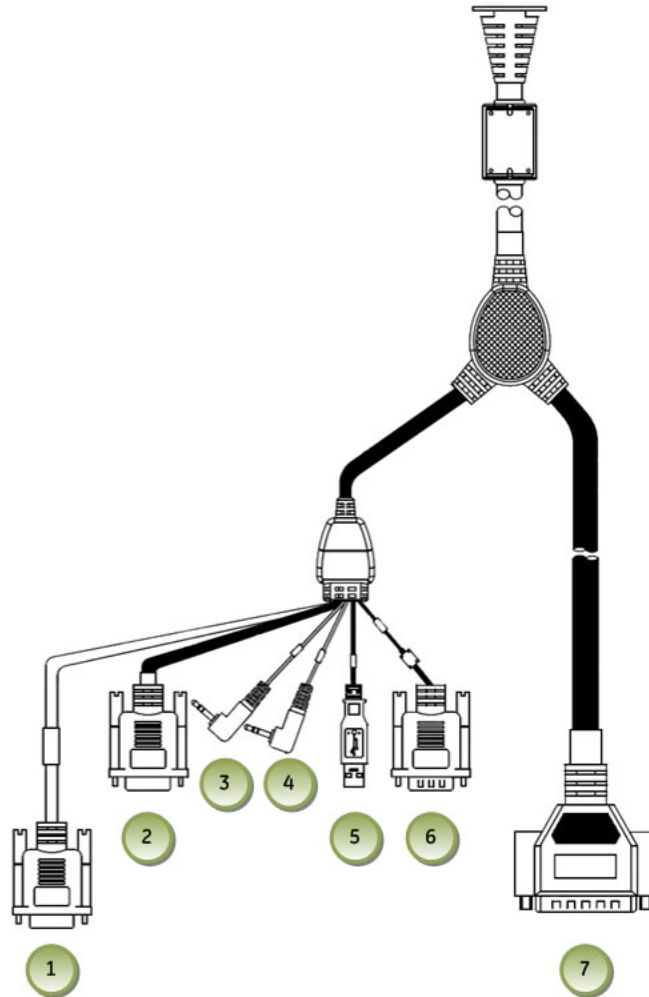


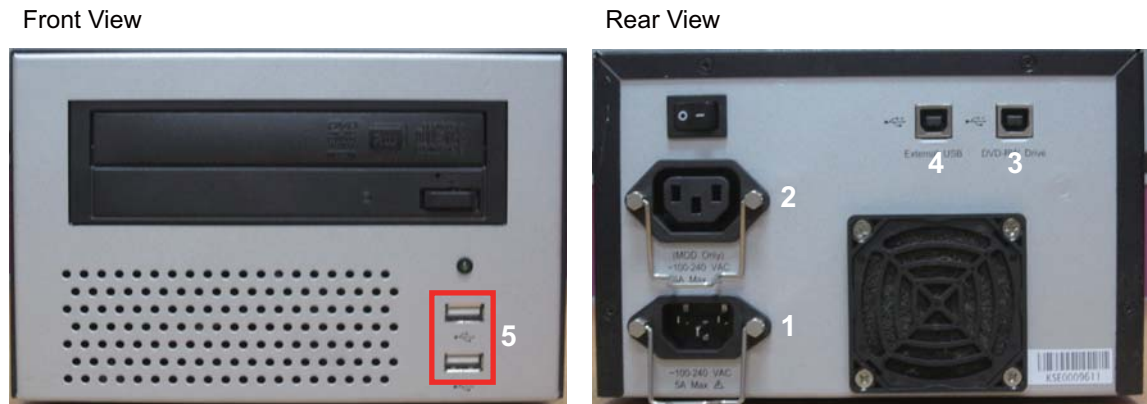
Figure 2-5 GSCB and Connection

ITEM	DESCRIPTION
1	GSCB - Black DB-9 (Female) Connector Host Computer DIP
2	GSCB - Gray DB-9 (Female) Connector Host Computer RS232
3	GSCB - Green Audio Connector Host Computer Audio Out (Green)
4	GSCB - Blue Audio Connector Host Computer Audio In (Blue)
5	GSCB - USB Connector Reserved
6	GSCB - Black DB-9 (Male) Connector AC Box J56
7	GSCB - Black DB-25 (Male) Connector TGP Gantry Cable

Table 2-5 GSCB Cables

2 - Install Power

3.2 Connecting the Media Tower (5270510-20/-21/-22)



- 1) Power for Media Tower
- 2) Power for MOD Drive
- 3) DVD-RW Drive
- 4) External USB
- 5) HDD External
SSA Key

Figure 2-6 Media Tower Connection shown (Single Bay)

Connect the power cable to the rear of the media tower. Use the following cables for connection.

DESCRIPTION	PART NUMBER	CABLE LENGTH	QTY
USB Cable (PMT)	5315370	2000 mm	2
Power Cable, Peripheral Tower to NIO AC Box	5432953-2	3050 mm	1

Table 2-6 Media Tower Cables

3.3 Connecting the LCD Monitor



NOTICE Equipment Damage Possible

Do not touch the video signal cable connector pins as this might bend them. When connecting the video signal cable, check the alignment of the HD15 connector. Do not force the connector in the wrong way, otherwise the pins might bend.

3.3.1 Connect Scan Monitor and Image Monitor for EIZO LCD:

Scan Monitor

- Video cable from Console Host DP0 to Monitor DVI
- Power cable from Console AC Box J10
- Route through the cable keeper



Figure 2-7 Video Cable and Power Cable

Display (Image) Monitor

- Video cable from Console Host DVI-I 0 to Monitor D-SUB
- Power cable from Console AC Box J9
- Route through the cable keeper



Figure 2-8 Video Cable and Power Cable

DESCRIPTION	PART NUMBER	CABLE LENGTH	QTY
Scan Monitor Power Cable	5432953-4	3050 mm	1
Scan Monitor Video Cable	5408703	3000 mm	1
Display Monitor Power Cable	5432953-3	3050 mm	1
Display Monitor Video Cable	5332107-2	3050 mm	1

Table 2-7 Monitor Cables

2 – Install Power

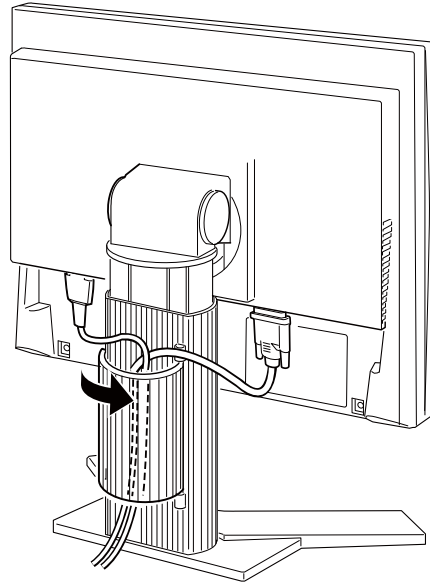


Figure 2-9 Cable Routing and Keeper

3.3.2 Connect Scan Monitor and Image Monitor for HP LCD:



Figure 2-10 HP E190i LCD Monitor Connections

ITEM	DESCRIPTION
A	Power Cable Connection
B	DVI Video Connection – Prescription / Scan Monitor (left)
C	D-Sub (VGA) Video Connection – Display / Image Monitor (right)

Table 2-8 HP LCD Monitor Connections

Scan Monitor

- Video cable from Console Host PC DP to Monitor DVI
- Power cable from Console AC Box J10
- Route through the cable keeper

Display (Image) Monitor

- Video cable from Console Host PC DVI to Monitor D-SUB (VGA)
- Power cable from Console AC Box J9
- Route through the cable keeper

DESCRIPTION	PART NUMBER	CABLE LENGTH	QTY
Scan Monitor Power Cable	5432953-4	3050 mm	1
Scan Monitor Video Cable	5408703	3000 mm	1
Display Monitor Power Cable	5432953-3	3050 mm	1
Display Monitor Video Cable	5332107-2	3000 mm	1

Table 2-9 Monitor Cables

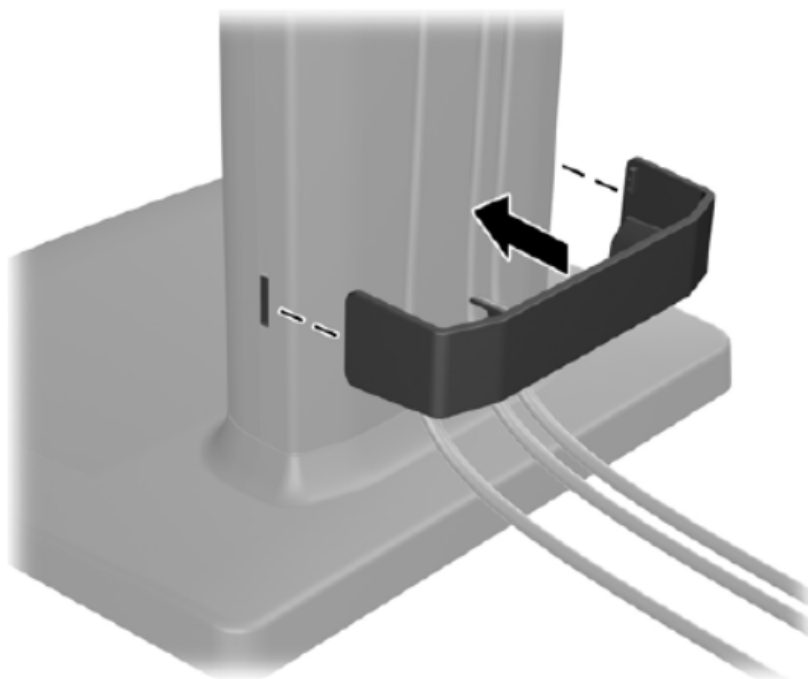


Figure 2-11 Cable Routing and Keeper

3.3.3 LCD Video Monitor Setup

Detail LCD video monitor setup please refer to **Service Methods** → **Align, Setup, Cals** → **Console** → **LCD Video Monitor Setup**.

3.4 Host Computer Connections



NOTICE

Potential for equipment damage Never connect a mouse or keyboard with the host computer powered "ON". Doing so can destroy components within the host computer.

- 1.) Open the right side of the console rear panel.

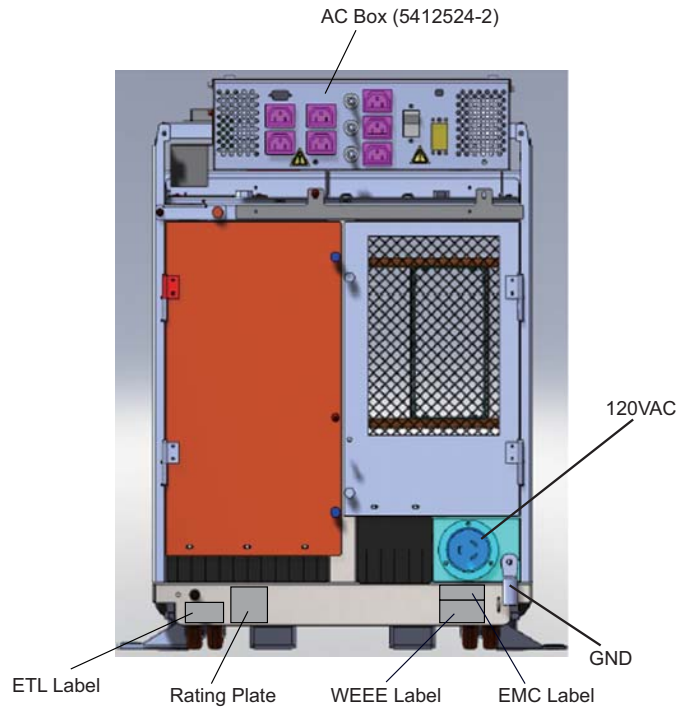


Figure 2-12 NIO Rear View

- 2.) Connect the all cables (see [Table 2-4](#)) to the rear of Host Computer referring to the drawing below ([Figure 2-13](#)).The drawing is also printed on the right rear door of the console.

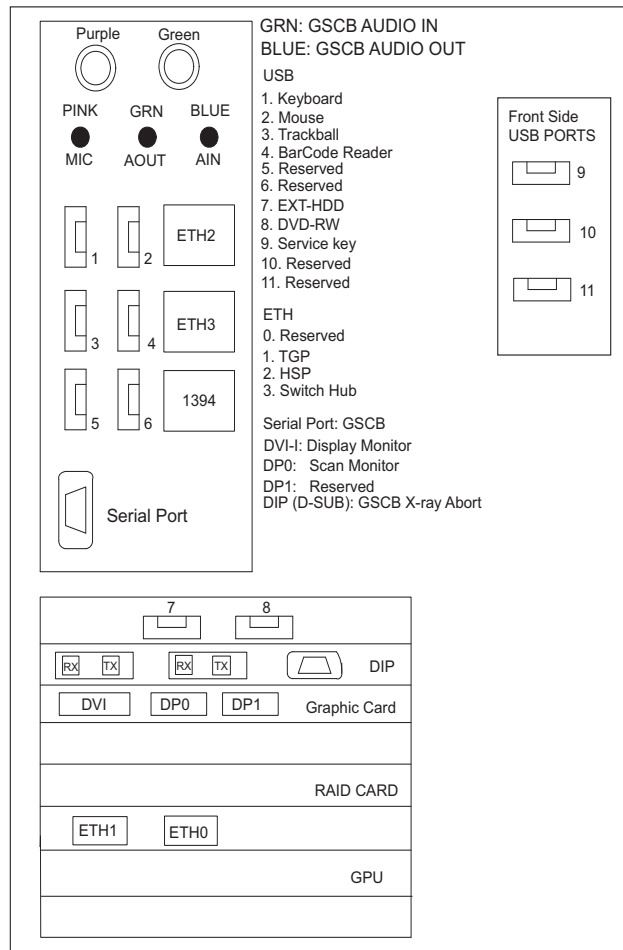


Figure 2-13 Host Computer (Z820) Connections

2 – Install Power

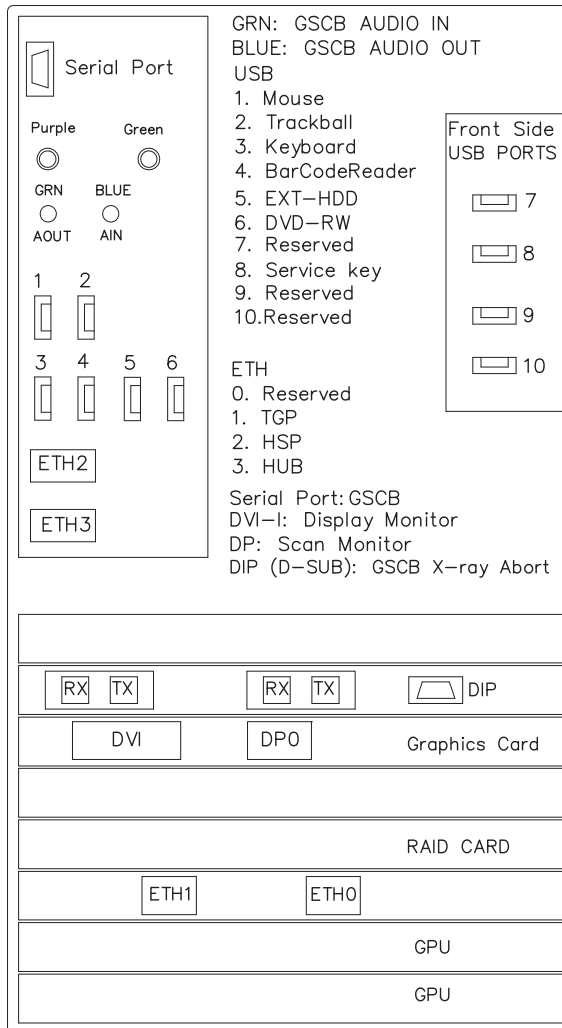


Figure 2-14 Host Computer (Z840) Connections

3.5 Switch Hub Connections

Switch Hub located on the left bottom of the console. Plug cables into Switch Hub on console.

Figure 2-15 Switch Hub Location

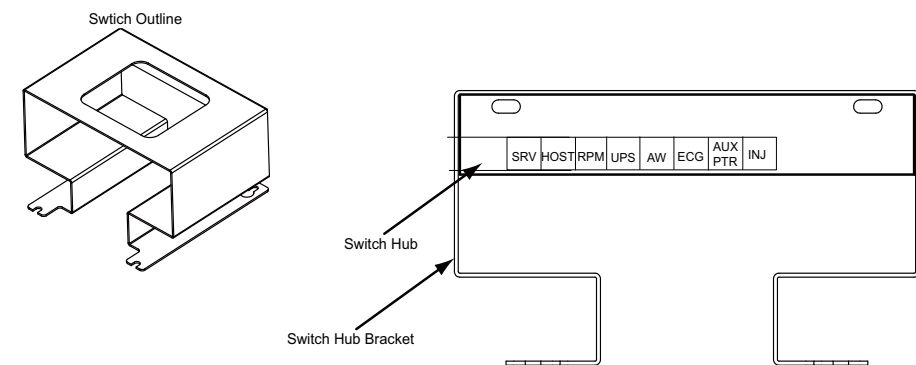
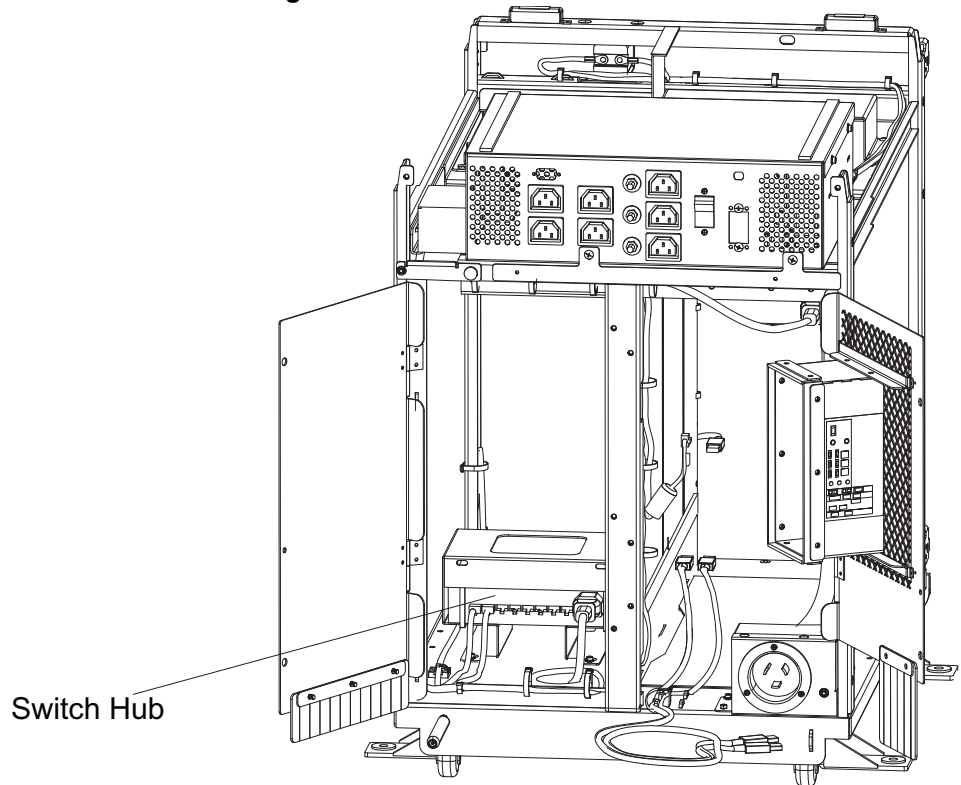


Figure 2-16 Switch Hub Connections

3.6 AC Box Connections

CAUTION The outlets are not for General Use. Operator Console outlet has a rating for 2.5A at 120VAC. Accessories should not exceed above rating.

Note: Console power is single phase power. Outlet assigned is not critical.

- 1.) Connect the console power cable and ground cable to the console power panel.
- 2.) Connect console component power cords as listed in Table 2-10. ("J numbers" increment from top to bottom, left to right)

Number	Description
J9	Display Monitor Power Connection
J10	Scan Monitor Power Connection
J11	Peripheral Media Tower Power Connection
J12	In-Room Monitor Connection
J13	Injector Power Connection
J14	RPM Power Connection
J56	GSCB Power Connection

Table 2-10 AC Box Outlet Assignments

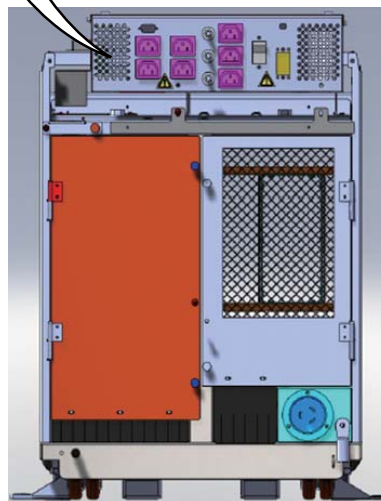
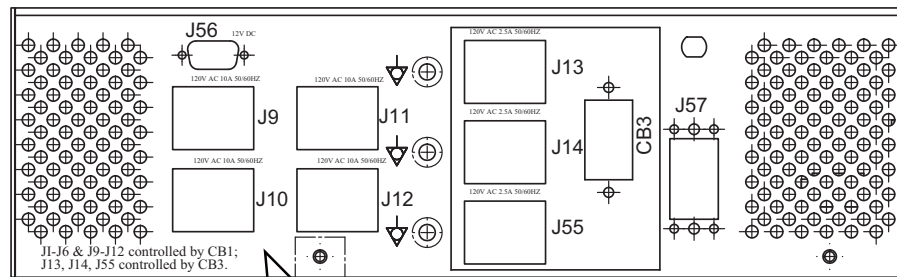


Figure 2-17 AC Box Connections

3.7 Cable Arrangement

Arrange the cables appropriately by using the cable clamps equipped on the console tables.

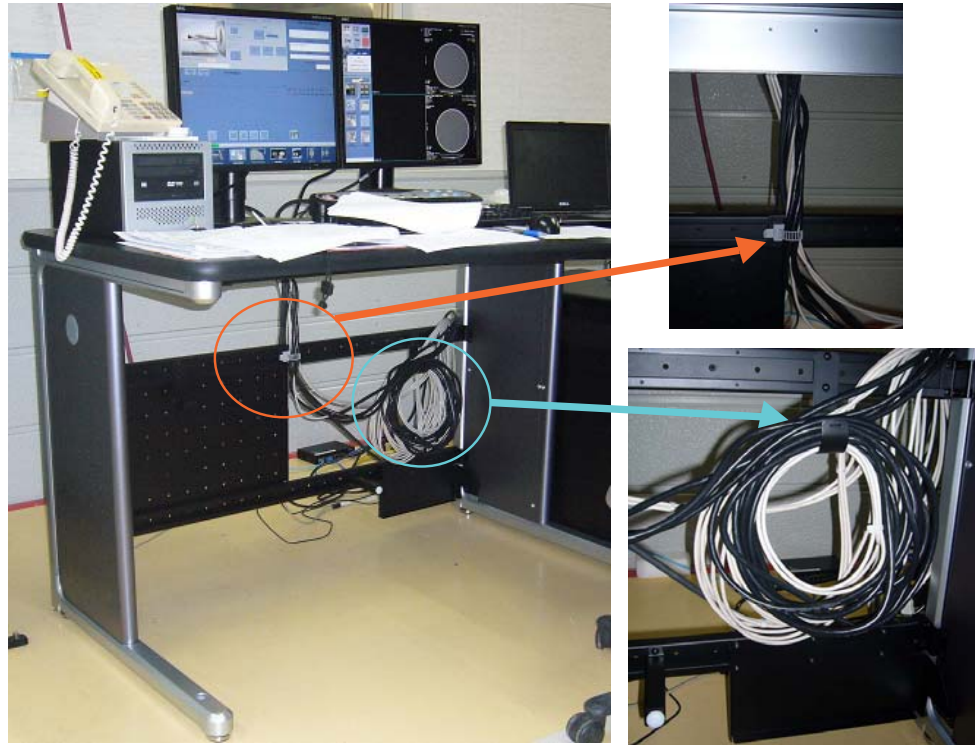


Figure 2-18 Example: Cable Arrangement

Section 4.0 OpenOC Console Connections

4.1 GSCB, Keyboard, Trackball & Mouse Installation

PART #	DESCRIPTION	CONNECT TO	QUANTITY	LENGTH	
				MM	INCHES
5431909	Cable, USB_Extend	Keyboard	1	3500 ± 50	137.8 ± 1.97
5458346	USB EXTENSION CABLE	Mouse	1	3500 ± 50	137.8 ± 1.97
5315370	CABLE, USB TYPE A-B	PMT media Tower, DVD-RW/USB external HDD	2	2000	78.74
5408703-2	DP to DVI cable, 3 meter	Monitor	1	3000 ± 50	118.11 ± 1.97
5641358	3m DVI-D to DVI-D cable, male to male, single link, for display monitor	Monitor	1	3000 ± 20	118.11 ± 0.79
5432953-6	Power Cable, Peripheral Tower to Open Chassis J5	PMT media Tower	1	3050 ± 50	120 ± 1.97
5478299-6	Power Cable, Display monitor to Open Chassis Console	Monitor	1	3050 ± 50	120 ± 1.97
5478299-5	Power Cable, Scan monitor to Open Chassis Console	Monitor	1	3050 ± 50	120 ± 1.97

Table 2-11 GE Healthcare Supplied OpenOC (Z840 Host Computer) Cables

- 1.) Route the keyboard cable under the GSCB, as shown in [Figure 2-3](#).

NOTICE



Potential for equipment damage

Never connect a mouse or keyboard with the host computer powered “ON”. Doing so can destroy components within the host computer.

- 2.) Route the keyboard and mouse cables to OpenOC.
If the length of keyboard and mouse cables is not enough, add the following cable extensions (shipped with OC collector).

DESCRIPTION	PART NUMBER	CABLE LENGTH	QTY
USB extension Cable (Mouse) for Z840 host computer	5458346	3500 mm	1
USB Cable (Keyboard)	5431909	3500 mm	1

Table 2-12 Cable Extension

- 3.) Select the local language overlay from the keyboard collector (5431062-1-XX) for your system.
 - Select keyboard overlay from keyboard collector (5324605-XX) to attach. (See [Figure 2-4](#))

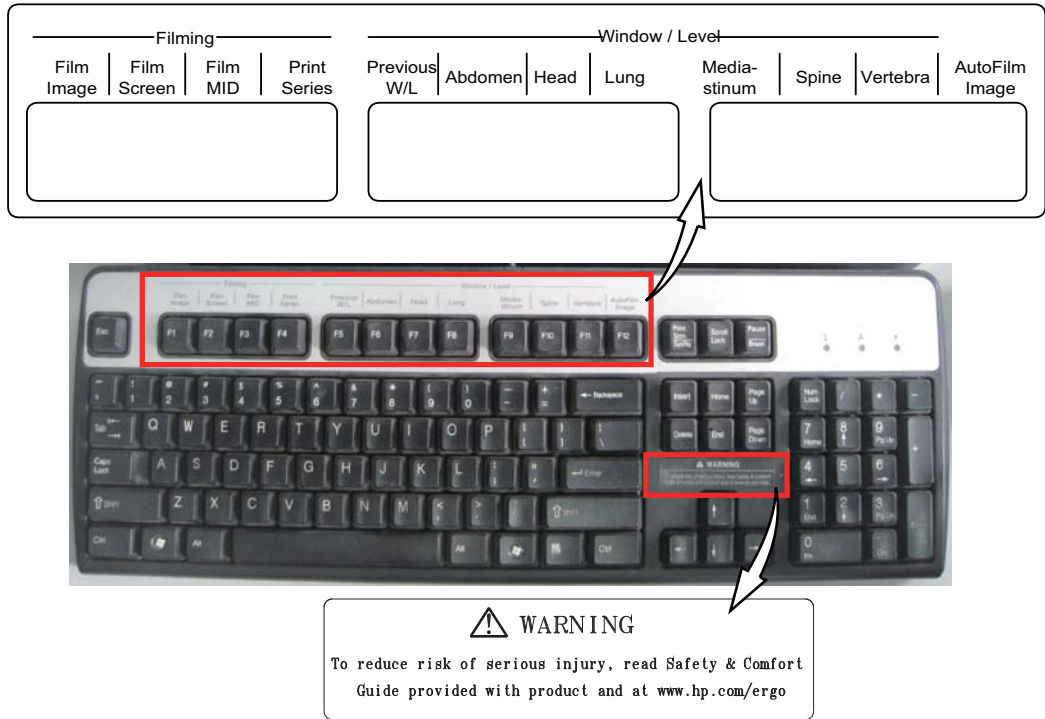


Figure 2-19 Keyboard with the English film and Warning Label Installed

- Select the GSCB overlay (with both Tilt and E-Reset, P/N is 5401237-XXX) install the proper overlay with the appropriate language for the system.

Verify that none of the buttons get caught and stuck under the overlay. Pay close attention to the prescribed tilt button on systems with the tilt feature.

Note: X-ray ON sound can be turned off / on using the switch on GSCB bottom if customer does not like it and if local regulation does not require X-ray ON sound. Detail information refer to **Service Methods->Troubleshooting->Console-> GSCB Troubleshooting**.

- 4.) The keyboard should attach to the GSCB using the supplied Velcro strip and fit snugly against the GSCB when finished, as shown in [Figure 2-3](#).
- 5.) Route the GSCB cable and connect connectors according to [Figure 2-20](#) and [Table 2-13](#)

Note: The USB cable of GSCB is reserved, please tie it with tie-wrap.

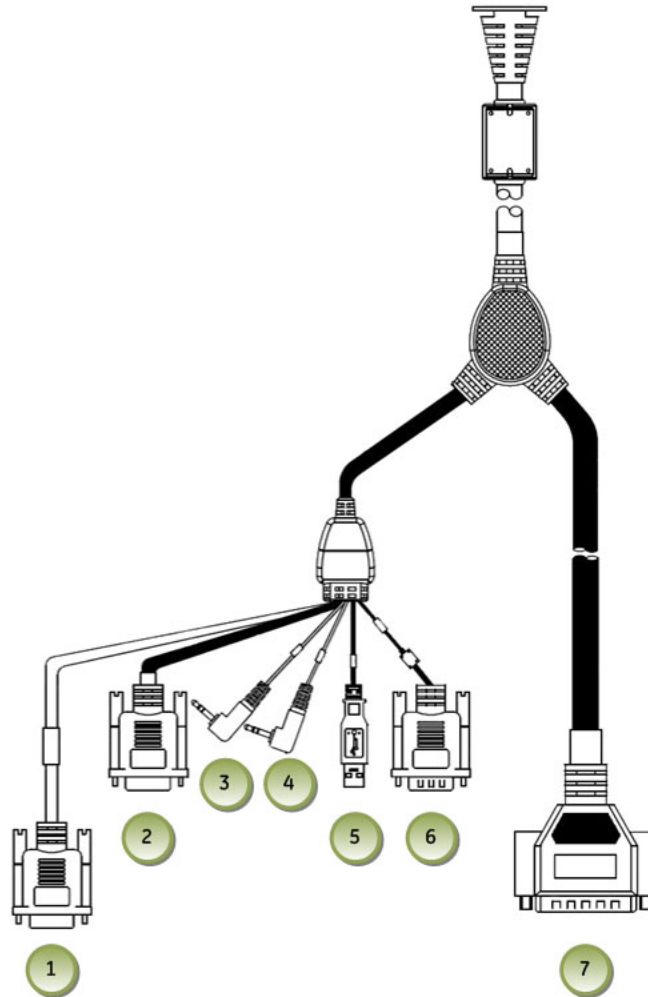
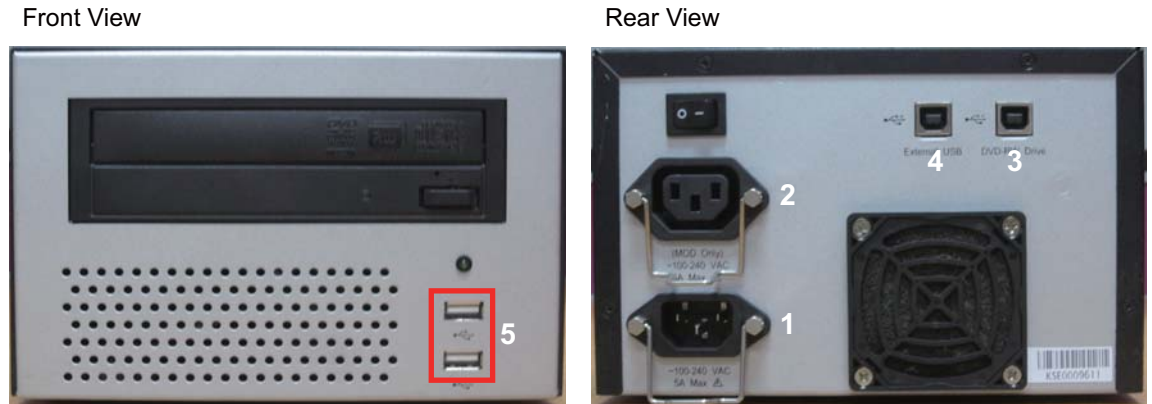


Figure 2-20 GSCB and Connection

	ITEM	DESCRIPTION
1	GSCB - Black DB-9 (Female) Connector	Host Computer DIP
2	GSCB - Gray DB-9 (Female) Connector	Host Computer RS232
3	GSCB - Green Audio Connector	Host Computer Audio Out (Green)
4	GSCB - Blue Audio Connector	Host Computer Audio In (Blue)
5	GSCB - USB Connector	Reserved
6	GSCB - Black DB-9 (Male) Connector	AC Box J56
7	GSCB - Black DB-25 (Male) Connector	TGP Gantry Cable

Table 2-13 GSCB Cables

4.2 Connecting the Media Tower (5270510-22)



- 1) Power for Media Tower
- 2) Power for MOD Drive
- 3) DVD-RW Drive
- 4) External USB
- 5) HDD External SSA Key

Figure 2-21 Media Tower Connection shown (Single Bay)

Connect the power cable to the rear of the media tower. Use the following cables for connection.

DESCRIPTION	PART NUMBER	CABLE LENGTH	QTY
USB Cable (PMT)	5315370	2000 mm	2
Power Cable, Peripheral Tower to OpenOC	5432953-6	3050 mm	1

Table 2-14 Media Tower Cables

4.3 Connecting the LCD Monitor



NOTICE Equipment Damage Possible

Do not touch the video signal cable connector pins as this might bend them. When connecting the video signal cable, check the alignment of the HD15 and DVI connector. Do not force the connector in the wrong way, otherwise the pins might bend.

4.3.1 Connecting the Scan Monitor and Image Monitor for z840 Host Computer

DESCRIPTION	PART NUMBER	CABLE LENGTH	QTY
Scan Monitor Power Cable	5478299-5	3050 mm	1
Image Monitor Power Cable	5478299-6	3050 mm	1
Scan Monitor Video Cable	5408703-2	3000 mm	1
Image Monitor Video Cable	5641358	3000 mm	1

Table 2-15 Monitor Cables for Z840

Figure 2-22 LCD Monitor



ITEM	DESCRIPTION
A	Power Cable Connection
B	DVI Video Connection – Prescription / Scan Monitor (left)
C	D-Sub (VGA) Video Connection – Display / Image Monitor (right)

Table 2-16 LCD Monitor Connections

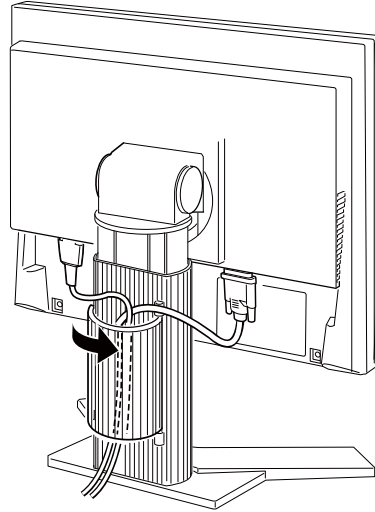
Scan Monitor

- Video cable: Z840 PC DP to Monitor DVI
- Power cable: AC Box J1 to Monitor power

Image Monitor

- Video cable: Z840 PC DVI to Monitor VGA
- Power cable: AC Box J2 to Monitor power

Figure 2-23 Cable Routing and Keeper

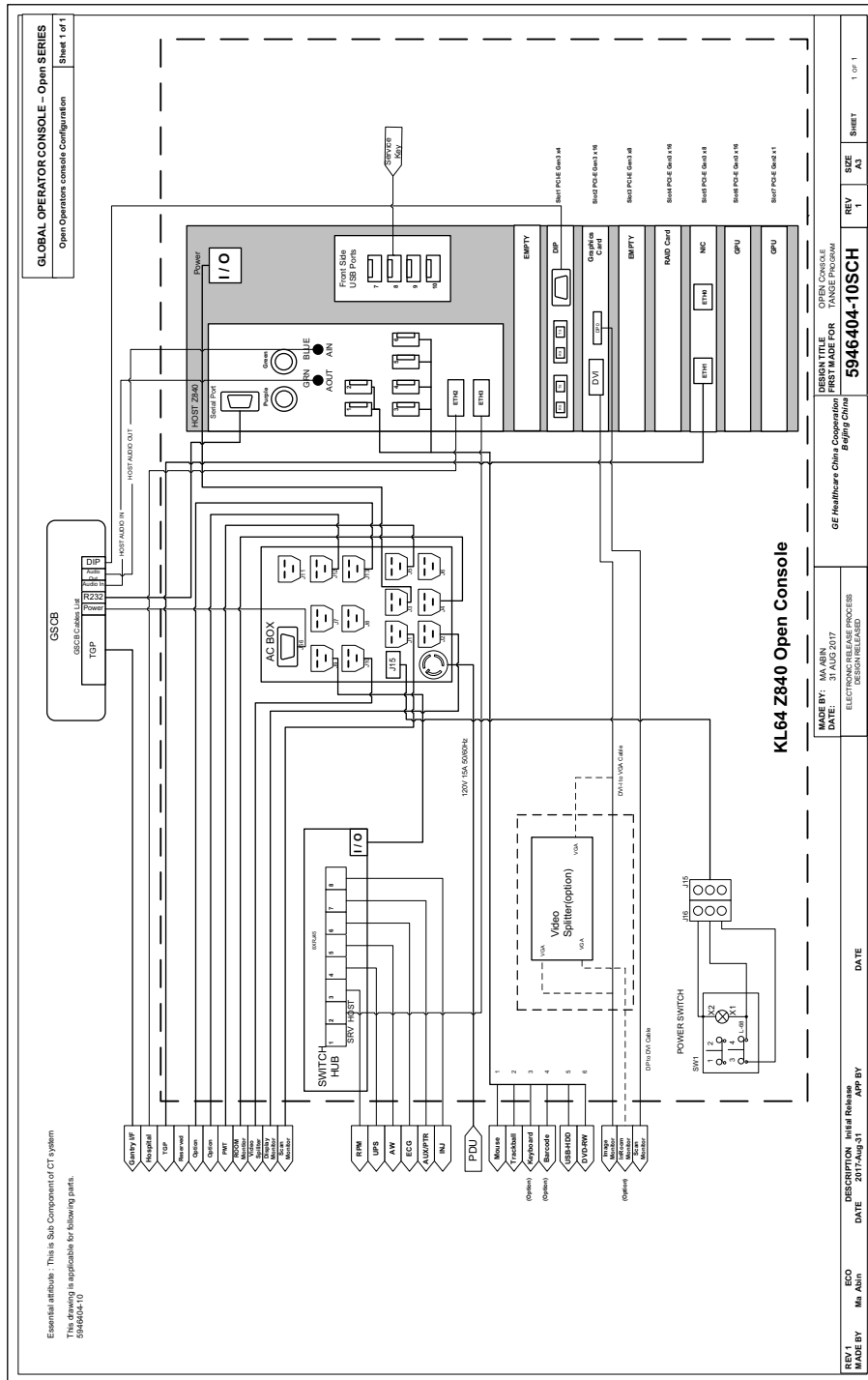


4.3.2 LCD Video Monitor Setup

Detail LCD Video Monitor Setup please refer to **Service Methods**→**Align, setup, Cals**→**Console**→ **LCD Video Monitor Setup**.

4.4 OpenOC Interconnect

Figure 2-24 OpenOC Interconnect_z840 Host Computer



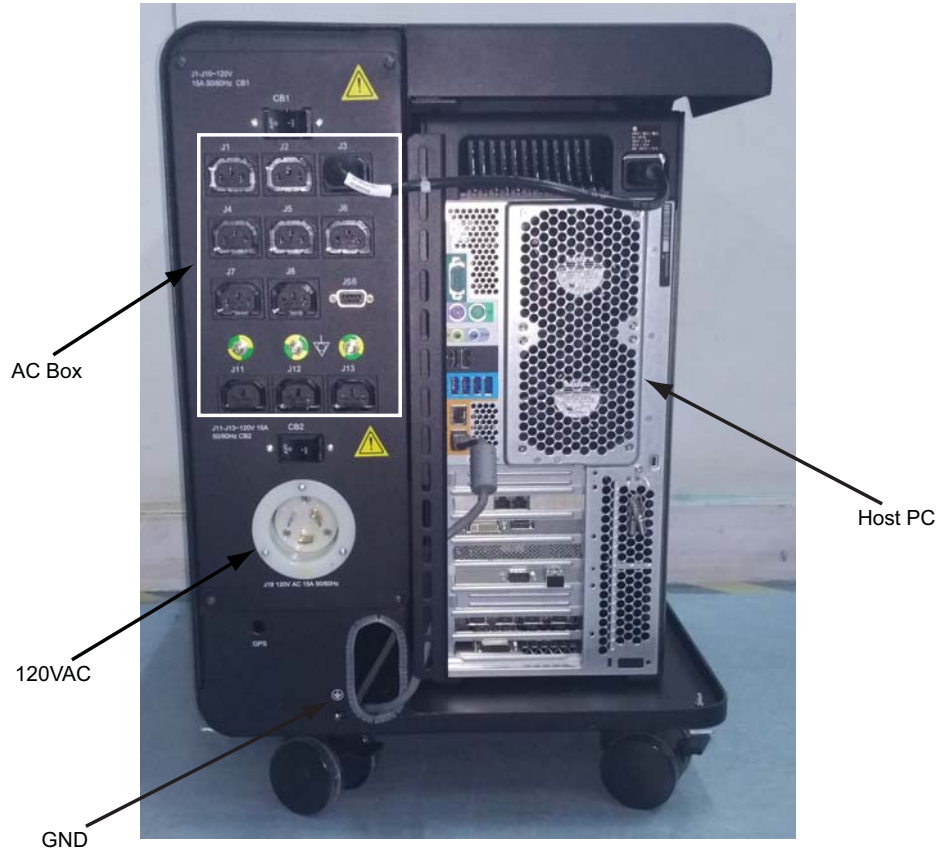
4.5 Host Computer Connections



NOTICE

Potential for equipment damage Never connect a mouse or keyboard with the host computer powered "ON". Doing so can destroy components within the host computer.

Figure 2-25 Open Console Rear View with AC BOX



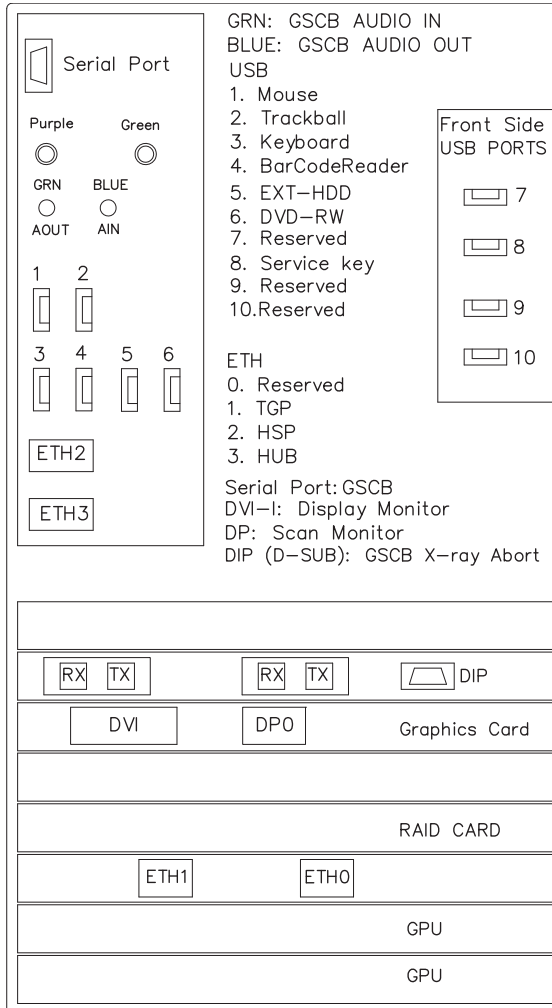
- 1.) Connect the power cable and ground cable to the console rear panel. (See [Figure 2-25](#))

PART NUMBER		DESCRIPTION
SHORT	LONG	
2343531-2	2343531	120VAC Power Cable from PDU to OC
2371450-4	2371450-3	Ground, Raceway to OC

Table 2-17 Console Cable Connections

- 2.) Connect the all cables (see [Table 2-11](#)) to the rear of Host Computer referring to the drawing below ([Figure 2-26](#)).The drawing is also printed on the right rear door of the console.

Figure 2-26 Z840 Host Computer Connections



4.6 Network Switch Hub Connections

Network Switch located inside the OpenOC chassis. Plug cables into Network Switch on console.

Figure 2-27 Network Switch Hub Location

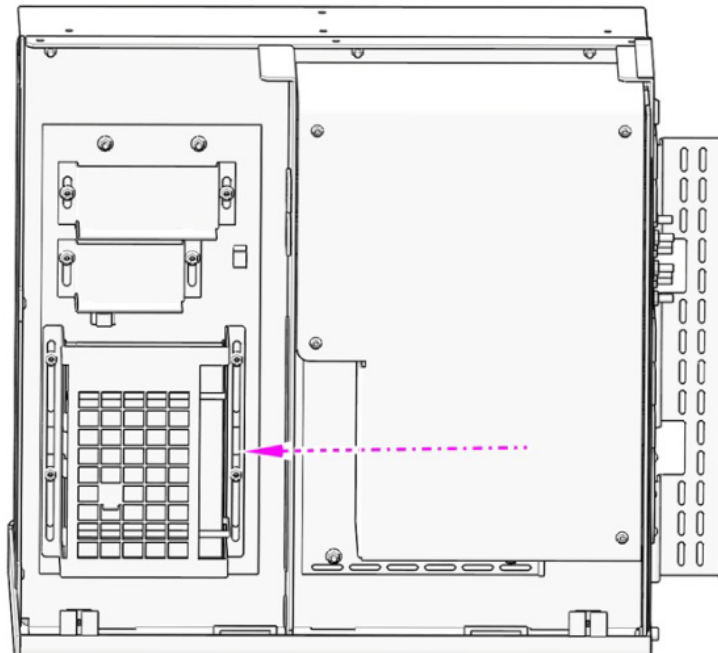
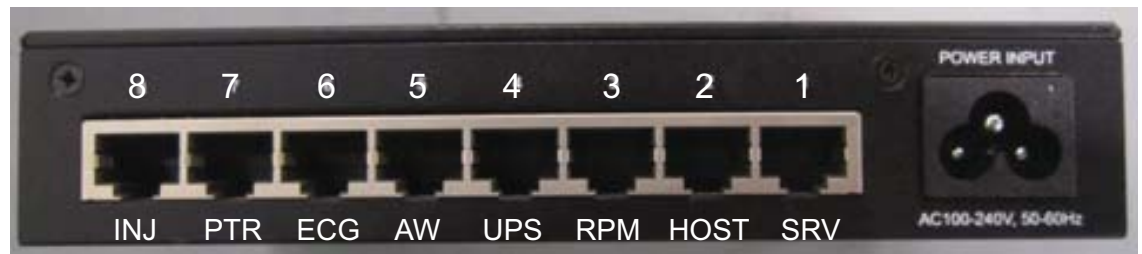


Figure 2-28 Network Switch Hub Connections



4.7 AC Box Connections

CAUTION The outlets are not for General Use. Operator Console outlet has a rating for 2.5A at 120VAC. Accessories should not exceed above rating.

Note: Console power is single phase power. Outlet assigned is not critical.

- 1.) Connect the console power cable and ground cable to the console power panel.
- 2.) Connect console component power cords as listed in [Table 2-18](#). ("J numbers" increment from top to bottom, left to right)

Number	Description
J1	Scan Monitor Power Connection
J2	Display Monitor Power Connection
J4	In-Room Monitor Connection
J5	Peripheral Media Tower Power Connection
J12	RPM Power Connection
J13	Injector Power Connection
J56	GSCB Power Connection

Table 2-18 AC Box Outlet Assignments

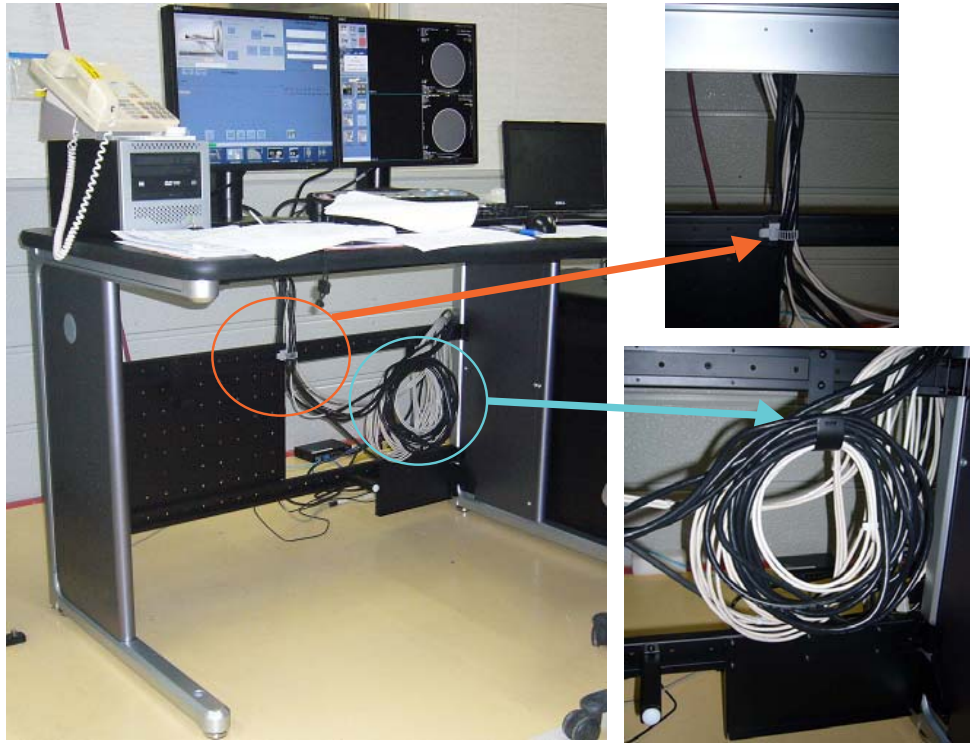
Figure 2-29 Open Console AC Box Connections



4.8 Cable Arrangement

Arrange the cables appropriately by using the cable clamps equipped on the console tables.

Figure 2-30 Example: Cable Arrangement



Section 5.0 Install Options

Note: Most shipped options can be located on the lean cart. Only large options such as the UPS and Smart Step will arrive on its own skid.

5.1 Install USB Barcode Reader

- 1.) Locate the barcode reader box on the lean cart options section.
- 2.) Consoles with 4 USB ports.
- 3.) Connect the USB cable to port USB A on the back of the console.
- 4.) Dress any excess cable and place under the monitor desktop.

5.2 Install Optional Remote Monitor

Follow the installation procedures in the Remote Monitor box.
For console wiring, refer to [Appendix D](#) in this manual.

5.3 Install Accessory I/F Hardware (IPC) Option

Follow the instructions shipped with the option.

Note: 8-port Ethernet switch is pre-installed on Optima CT680 Gantry. Ignore the section of LAN Switch installation in the option installation manual.

5.4 Install Respiratory Gating Option

Follow the instructions shipped with the option. The options board should be only mounted on the non-motor side of the gantry. Neatly dress all cables along the gantry base so that the base covers fit properly.

5.5 Install Injector Option

Follow the instructions shipped with the option. If this is a ceiling-mounted option, check that the plate is installed correctly with the holes in the correct location.

Mavig ceiling mounting plate. Customer installs this plate.



Mavig safety chain bracket.

5.6 Install Cardiac Gating IVY Monitor and Stand Option

Follow the instructions shipped with the Monitor and stand kit. Review the instructions carefully before assembling the stand and accessory basket to avoid repeated steps. Connect to the option interface panel, See Chapter 2 Section [6.2](#).

5.7 Customer Accessories - Head Holders and Extender

Open the boxes and installed the appropriate language warning labels.

The head holders are shipped with shims that require installation to ensure proper fit. Check that shims are included. Follow the shim procedure in Chapter 3, Section 3. The holder should fit snugly.

5.8 UPS Installation

If the site has an Uninterruptible Power Supply (UPS), please refer to UPS Installation for Direction *5174051-100 for Powerware 9155 UPS*. This manual should be shipped with the UPS. Use caution when removing the UPS from the skid. The UPS weight is 170kg (375lb).

5.9 Flat Tabletop used with Respiratory Gating

Follow the installation instructions with the Option.

5.10 SmartStep Installation

Follow the instruction shipped with option.

For the installation of the additional Gantry hardware (e.g. Gantry accessory panels and cables), refer to Accessory I/F Hardware option installation manual (5317058-1EN).

Section 6.0 Gantry Cable Connections

6.1 Gantry Cable Connections

Please refer to [Figure 2-2](#) for complete system interconnect details.

TO	FROM	CABLE DESCRIPTION
Gantry Power Pan	PDU	HVDC
Gantry Power Pan	PDU	440VAC
Gantry Power Pan	PDU	120VAC
Gantry Power Pan	Console	Fiber - <i>Take extreme care when you install the fiber optic DAS data cable. Do not step on, kink, or sharply bend this fragile DAS cable.</i>
Gantry Power Pan	Console	LAN
TGPG (J9)	Console	Control
TGPG (J11)	PDU	Control

Table 2-19 Gantry Cable Connections

- 1.) If using a rear cable entry box (B7850RC), install it now, before routing cables to gantry.

NOTICE



Potential for equipment damage.

Observe correct polarity when connecting the high voltage DC power. Reversing these leads will result in serious equipment damage. The HVDC positive conductors have red insulation and are labeled “ONE.” The HVDC negative conductors have black insulation and are labeled “TWO.” Lead “ONE” must be connected to lead “ONE,” and lead “TWO” must be connected to lead “TWO.”

Observe correct phase rotation when connecting the axial motor power. Phases one, two and three should be connected top to bottom.

- 2.) Install the cables to the gantry power pan. The power pan is located on the rear of the gantry at its base. See [Figure 2-31](#) and [Figure 2-33](#) for connections.

Note: The gantry 120VAC cable may not fit under the gantry frame. Install this cable before gantry placement—or remove the power plug—to route it under the gantry.

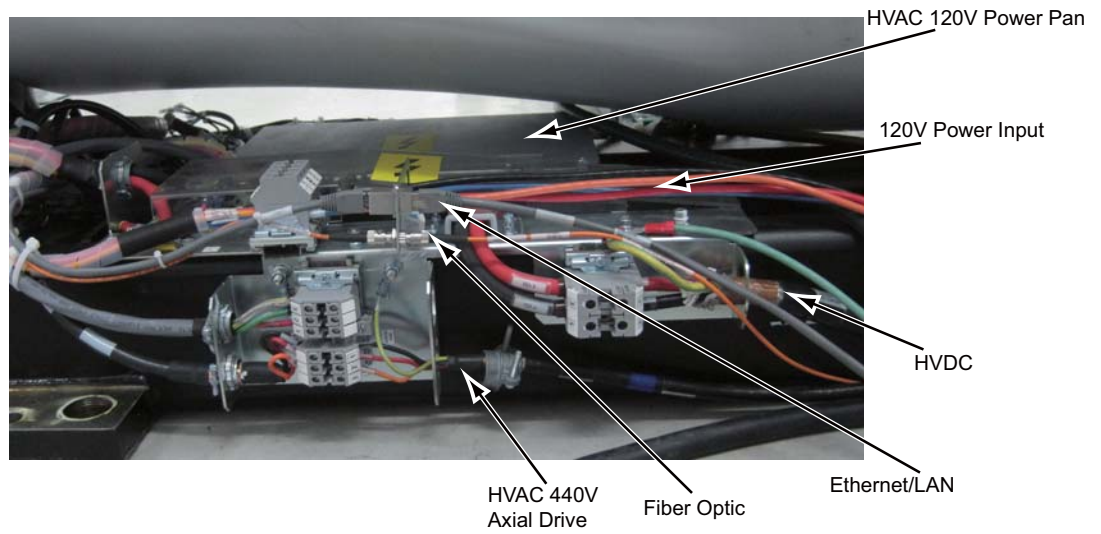


Figure 2-31 Gantry Power Pan Connections

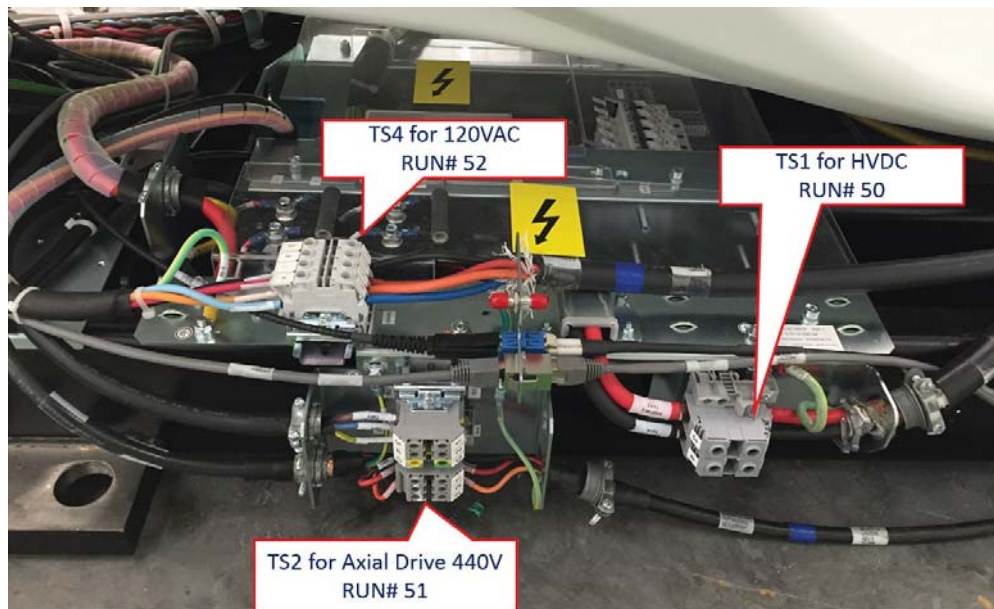


Figure 2-32 Gantry Power Pan Connections

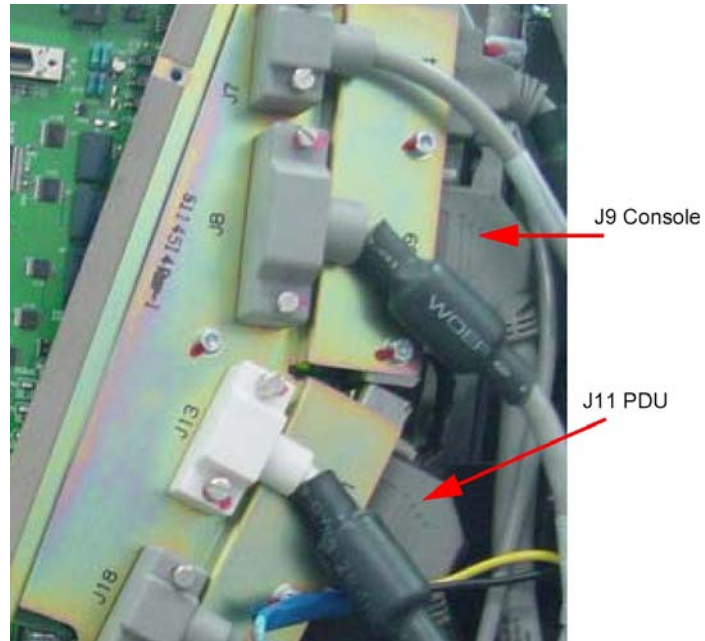


Figure 2-33 TGP Connections

3.) Install cables to the gantry TGP.

Note: 4.) Route J9 and J11 cables behind all cables at this area. See [Figure 2-34](#).



Route J9, J11 cables

Add a cable tie-wrap here



tie cables with hydraulic pipe

Figure 2-34 Route Cables

6.2 Cardiac Monitor Setup

Note: The following procedure is applied only if the Accessory I/F Hardware (IPC) Option is installed.

- 1.) Follow install instructions shipped with monitor to set up the monitor stand with basket.
- 2.) After the stand is assembled, mount the monitor to the stand by sliding the monitor onto the plate.
- 3.) Pull down the front pin on plate and slide monitor until it snaps into place.
- 4.) Secure the monitor using the two nylon set screws under the plate.
- 5.) Connect the long CAT5 LAN cable between back side of Gantry option interface and Console EKG port.

The long CAT5 cable is included in IVY Monitor kit.

- 6.) Attach the cables. *Do not use the cables shipped with the monitor*, find the 5317480 cable included with the Cardiac Cable Kit (E8007TB).

CAUTION The outlets are not for General Use. Gantry outlets have a rating for 3.0A at 120VAC. Accessories should not exceed above rating.

- 7.) Connect the IEC power cord, ground wire, LEMO and CAT5 to the gantry option interface panel. (See [Figure 2-35](#)).

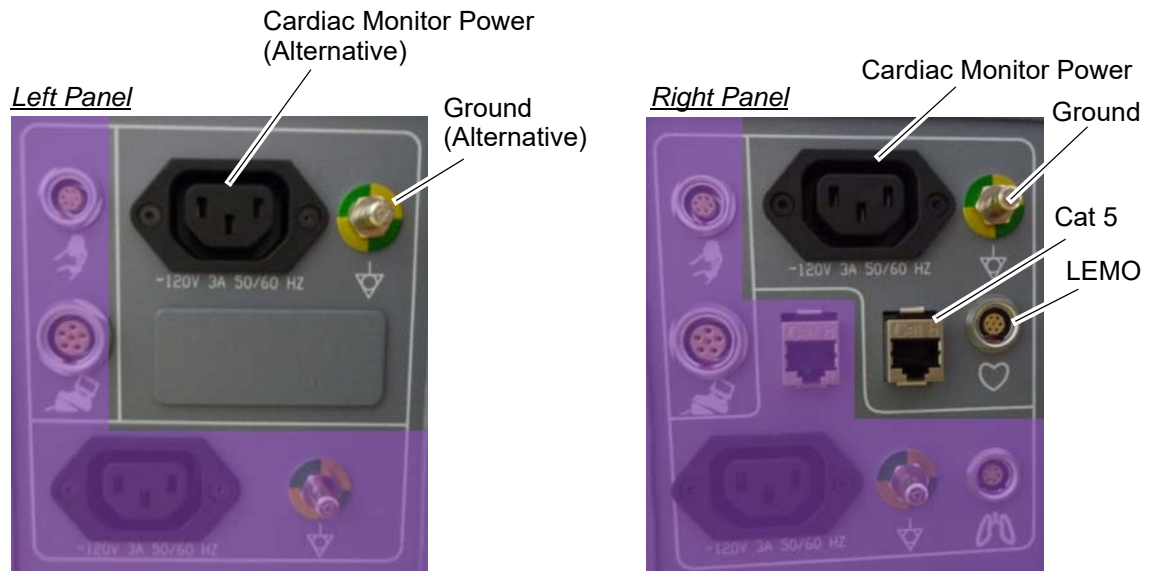


Figure 2-35 Gantry Option Interface Panel



If the wire power cord cable clamp is too short, replace it with the supplied longer clamp.

Figure 2-36 Connections on Rear of Cardiac Monitor (IVY3150)



Figure 2-37 Connections on Rear of Cardiac Monitor (IVY7800)

- 8.) Connect the power cord, ground wire, HD15 and CAT5 to the monitor panel.(See [Figure 2-36](#)).
- 9.) The cardiac monitor receives power from the gantry.
- 10.) Strain relief the cables to the monitor stand, and to the gantry base covers using tie-wraps. (See [Figure 2-38](#)).



Figure 2-38 Cables Strain Relieved to Stand

6.3 Respiratory Monitor Setup (Version 1.7)

Note: The following procedure is applied only if the Accessory I/F Hardware (IPC) Option is installed.

Note: Installation of the Respiratory Monitor is done by Varian Service.

CAUTION The outlets are not for General Use. Gantry outlets have a rating for 3.0A at 120VAC. Accessories should not exceed above rating.

- 1.) Power outlet, ground and LEMO connector for the Respiratory Monitor are provided as shown in Figure 2-39.

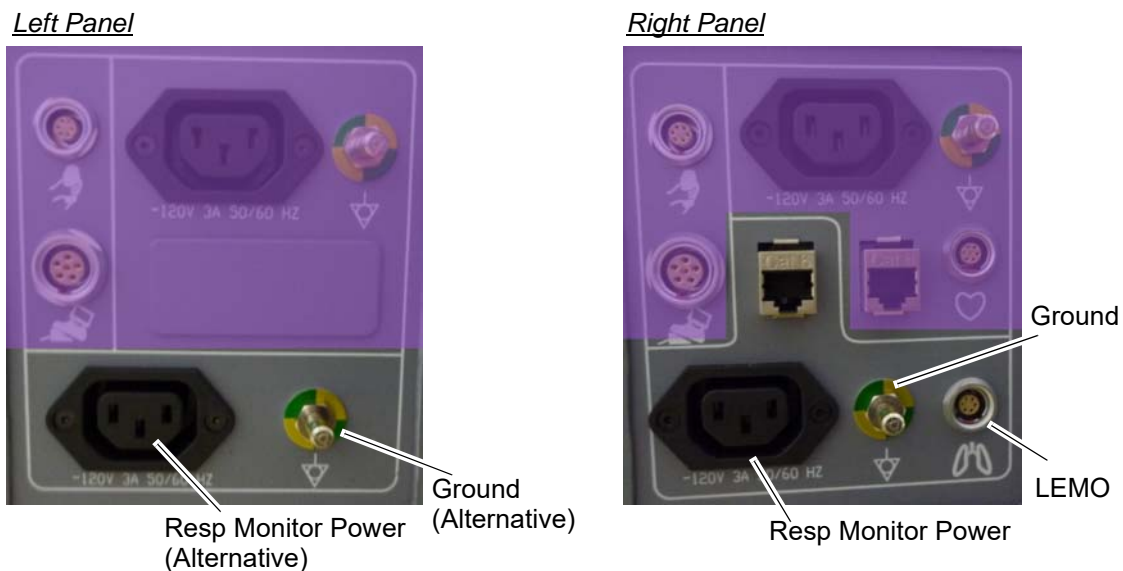


Figure 2-39 Option Interface Panel

Section 7.0 Table Connections (GT1700V)

Pull and connect the cables as described in [Table 2-20](#). The table cables are bundled with the gantry frame. Cut the cable ties to release bundles of cables.

Note: The footswitch connector and wiring harness may be run and secured to the ground bar assembly.

TABLE	FROM	CABLE DESCRIPTION
J1 table power	Gantry	120 VAC
J9 table control	Gantry	Signal Cable
Table ground	Gantry	Table ground

Table 2-20 Table Cable Connections

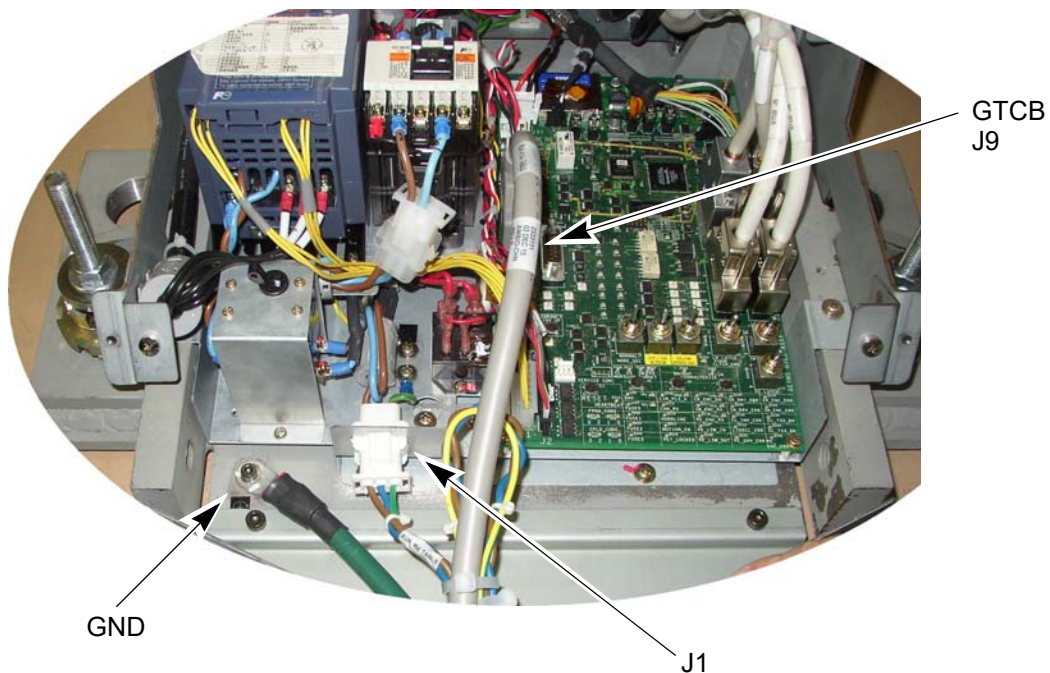


Figure 2-40 Table Connections

Note: You need to add the table ground cable and the footswitch adapter plate to ground bar, as shown.

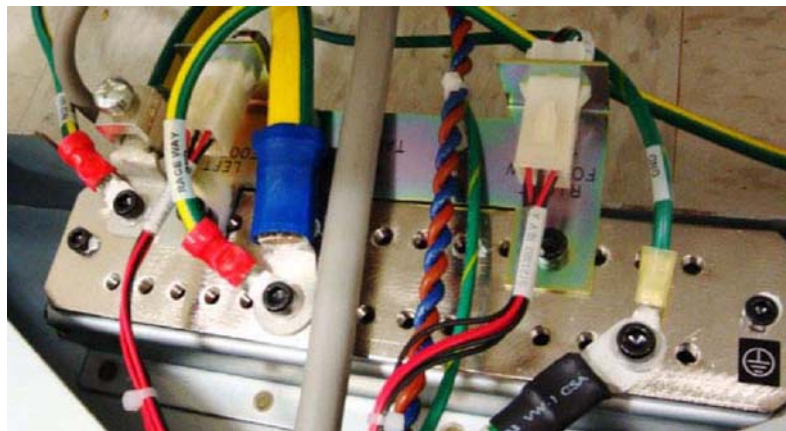


Figure 2-41 Finished Ground Bar Connections

Section 8.0 Table Connections (Lite Table)

Pull and connect the following cables:

J#	CABLE DESCRIPTION
J1	120 VAC
J9	Signal Cable

Table 2-21 Cables Connected to Table



Figure 2-42 Table Bulkhead Connections

Section 9.0

PDU Cable Connections & Configuration



CAUTION Do not work in an energized PDU. When working on the PDU, follow this simple rule: Always tag and lock out power to the PDU at the “main” disconnect. Failure to do so can result in electrocution or death.

Do NOT apply power to the PDU until all work has been completed and all PDU covers are in their proper place.

9.1 Introduction to NGPDU

As seen in Figure 2-43, a number of cables must be installed throughout the PDU. Specific details on each connection can be found in the sub-sections that follow. Use Figure 2-43 for reference. The PDU has been designed to have cables routed into the PDU from behind and/or beneath it.

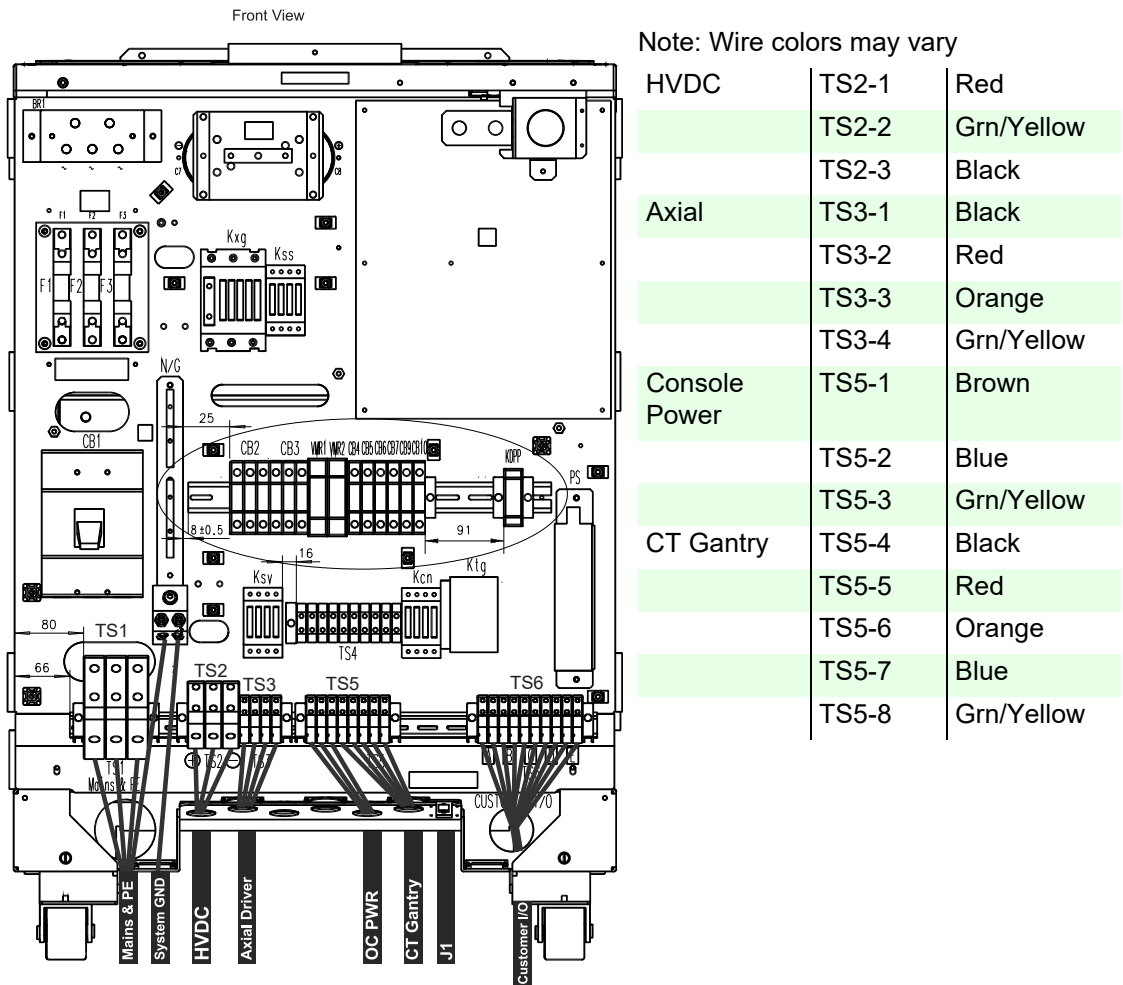


Figure 2-43 PDU Cable Connections - Front

9.1.1 Panel - 380 - 480VAC Mains “TS1” Input Power Connection

- 1.) Remove the TS3 panel front cover.
- 2.) Strip the wires to fit securely on the power block.
- 3.) Observe incoming phases (L1, L2 and L3) and insert bare leads into power block.
- 4.) Insert “vault” ground into PDU “vault” ground lug.
- 5.) Tighten all fasteners securely and replace the TS3 front panel.

Wire Size AWG	Driver	Bolt/Hex
#18 - 16	1.67 ft-lb (2.3 N-m)	6.25 (8.5 N-m)
#14 - 8	1.67 ft-lb (2.3 N-m)	6.25 (8.5 N-m)
#6 - 4	3.0 ft-lb (4.1 N-m)	12.5 (17 N-m)
#0 - 2/0		29 ft-lb (39.3 N-m)

Table 2-22 Power Wire Torque Values

Wire Size AWG	Driver	Bolt/Hex
#14 - 8	1.67 ft-lb (2.3 N-m)	6.25 (8.5 N-m)
#6 - 4	3.0 ft-lb (4.1 N-m)	12.5 (17 N-m)
#3 - 1		21 ft-lb (28.5 N-m)
#0 - 2/0		29 ft-lb (39.3 N-m)

Table 2-23 Ground Buss Bar Torque Values

9.1.2 Panel - Circuit Breakers

Place the circuit breakers in the “off/down” position during installation, even with Mains incoming power tagged and locked out. After you have completed work on the PDU, you may return the circuit breakers to the “ON” positions.

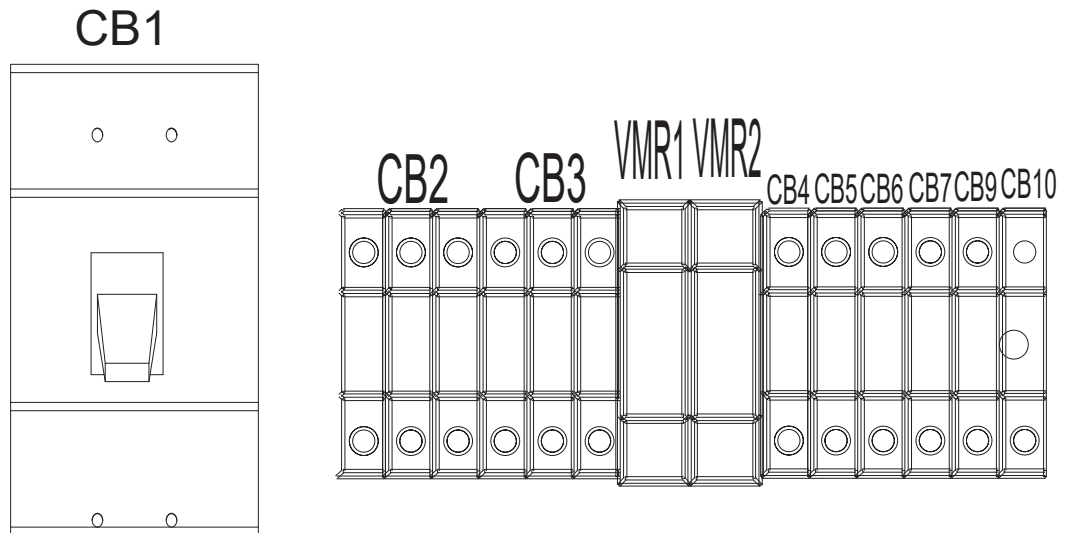


Figure 2-44 Circuit Breaker Panel

CIRCUIT BREAKER	DESCRIPTION
CB2	Circuit Protection (Axial Drive)
CB3	Full Winding Protection
CB4	CT Gantry Service Outlets
CB5	CT Gantry rotating loads
CB6	Table & CT Gantry Stationary Loads
CB7	Operator Console Load
CB9	VMR1, Control P.S Load
CB10	VMR2

Table 2-24 Panel Circuit Breaker Descriptions

9.1.3 HVDC Connection

Note: Refer to [Table 2-3, System Interconnect Cables on page 106](#).

Connect the internally shielded HVDC cable to TS2 on the standing panel. See [Figure 2-43](#) for the location of the connector and [Figure 2-45](#) for details. Observe polarities and grounds. Do not cut or shorten cables unless you have all of the appropriate tools and crimper to re-terminate. If short cables are needed, have the PMI order the short cable set.

WARNING

Excess cable length cannot be stored under or behind the PDU. If cables are to be stored in the cable tray, do not overfill. Consult the local electrician to determine the maximum fill rate for your area.

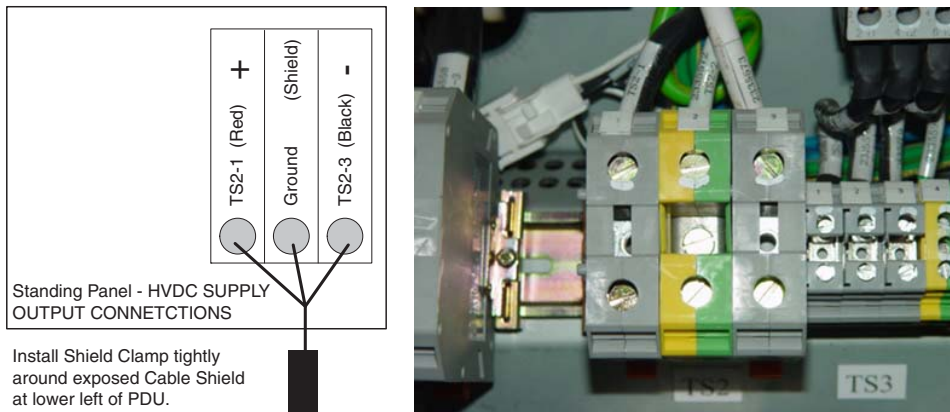


Figure 2-45 HVDC Connection

- Check box when complete.

9.1.4 440V Connection

Note: Refer to [Table 2-3, System Interconnect Cables on page 106](#).

Connect the internally shielded 440V cable to TS3 on the standing panel (See [Figure 2-43](#) for the location of the connector and [Figure 2-46](#) for details). Observe polarities and grounds. Do not cut or shorten cables unless you have all of the appropriate tools and crimper to re-terminate. If short cables are needed, have the PMI order the short cable set.

WARNING

Excess cable length cannot be stored under or behind the PDU. If cables are to be stored in the cable tray, do not overfill. Consult the local electrician to determine the maximum fill rate for your area.

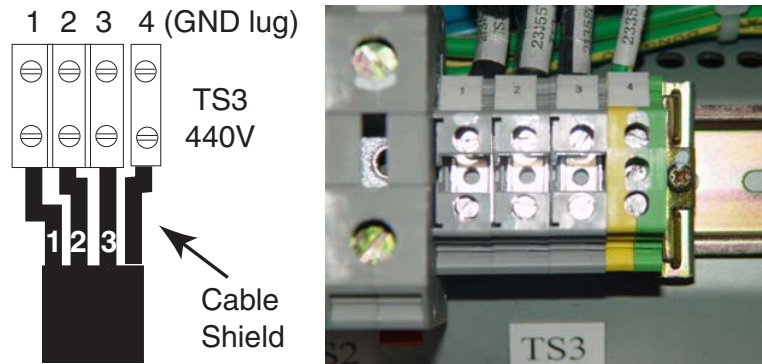


Figure 2-46 440VAC Connection

Check box when complete.

9.1.5 Gantry & Console Power Connections

Note: Refer to [Table 2-3, System Interconnect Cables on page 106](#).

Do not cut or shorten cables unless you have all of the appropriate tools and crimper to re-terminate. If short cables are needed, have the PMI order the short cable set.

WARNING

Excess cable length cannot be stored under or behind the PDU. If cables are to be stored in the cable tray, do not overfill. Consult the local electrician to determine the maximum fill rate for your area.

Plug the console power cable wires to TS5, 1-3 and the gantry power cable wires TS5, 4-8 as shown in [Figure 2-47](#).

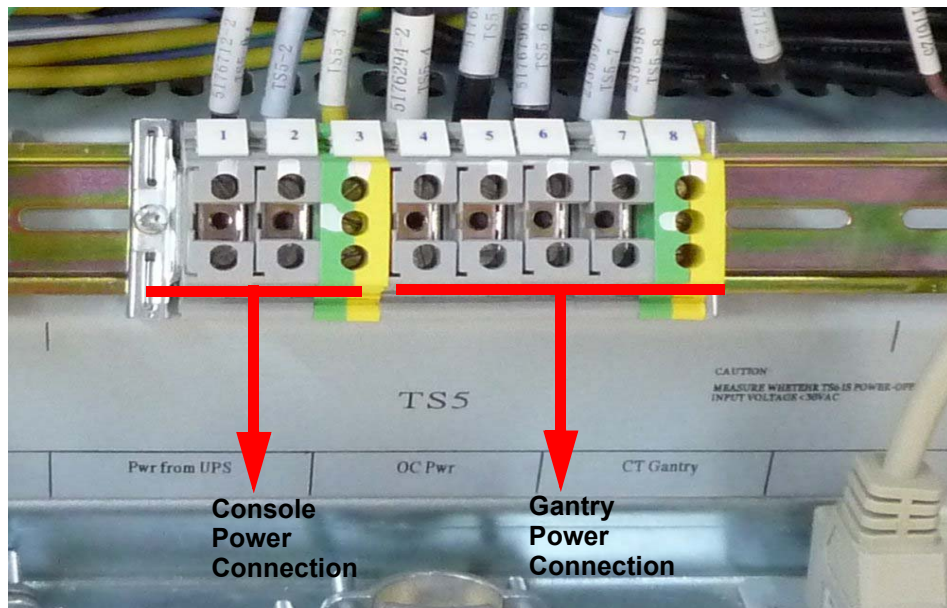


Figure 2-47 Gantry & Console Power Connections

- Check box when complete.

9.1.6 PDU Control Cable

The PDU control cable comes pre-terminated and should not be re-terminated in the field. Excess cable length must be stored. Simply plug the cable into J1 on the A panel. Secure it by using the fasteners integrated into cable's connector shell.

- Check box when complete.

9.1.7 System Ground Connection

Connect the ground wire (green with a yellow stripe) from the table/gantry raceway ground bus to the system ground lug in the PDU.



Figure 2-48 PDU System Ground Connection

9.1.8 Warning Light & Door Interlock Connections

9.1.8.1 Warning Light Configuration & Connection

- 1.) Warning Light is controlled by signals from the system.
- 2.) This step is site specific. The PDU by default is configured for “no” external warning light connection. If you have external warning lights, see [Figure 2-49](#) for proper connection.

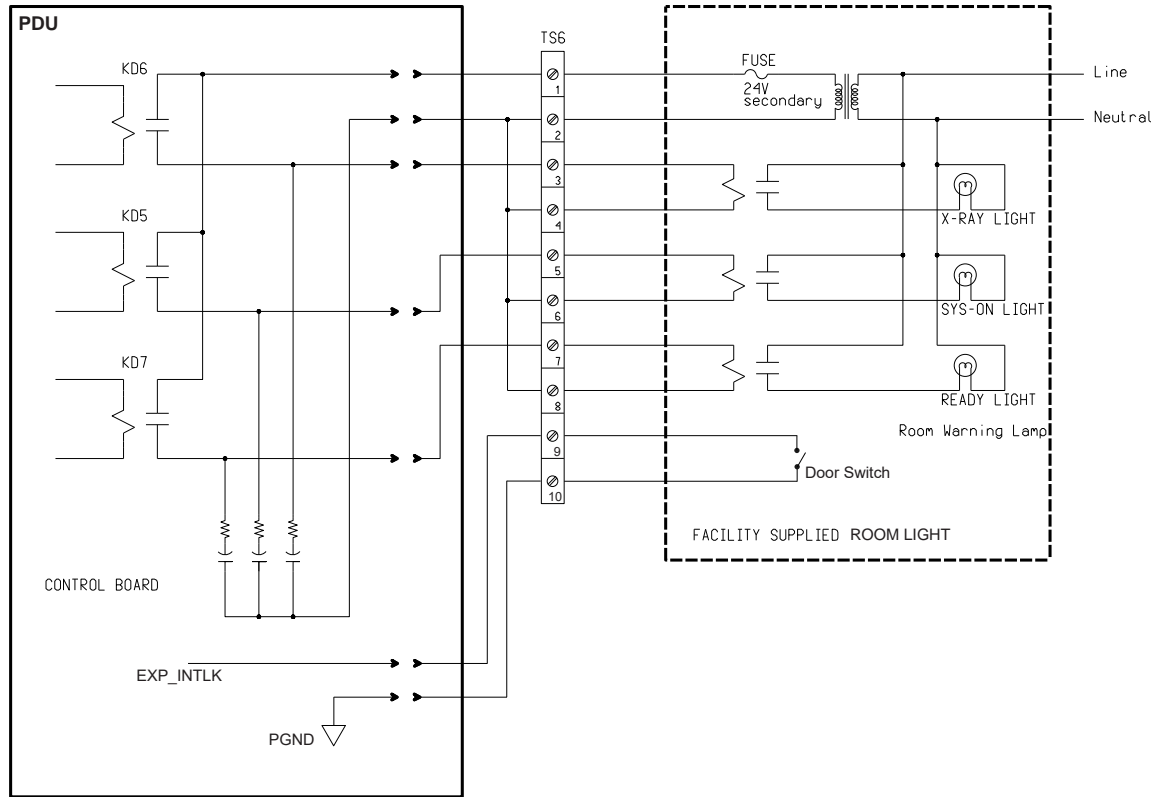


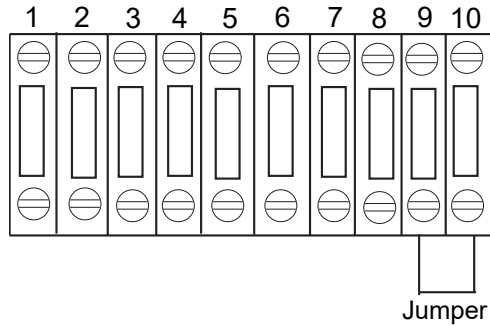
Figure 2-49 Typical TS6 Warning Light & Door Interlock Connections

It is recommended that you use the four (4) wire method of adding an X-ray warning light to a room, as shown in [Figure 2-50](#). When using this method, you:

- Minimize EMC interference.
- Increase contact life of the relay used in the PDU.

9.1.8.2 Door Interlock Connections

Door interlocks are used to prevent X-Rays from being generated when the scan room door is open. The Door Interlock circuitry in the PDU is shipped from the factory engaged. This means the system cannot generate X-ray until disengaged. A short must exist between pins 9 & 10 for X-ray to be generated. Using a small piece of wire, short pins 1 and 2 together. See [Figure 2-50](#).



If not using a door switch, add a jumper.

If jumper is not in place, exposures will not be made. Check this jumper if you get scan interlock errors.

Figure 2-50 Without a Door Interlock

To use the system with a door interlock, wire a normally open switch between pins 1 & 2 that is attached to the interlock.

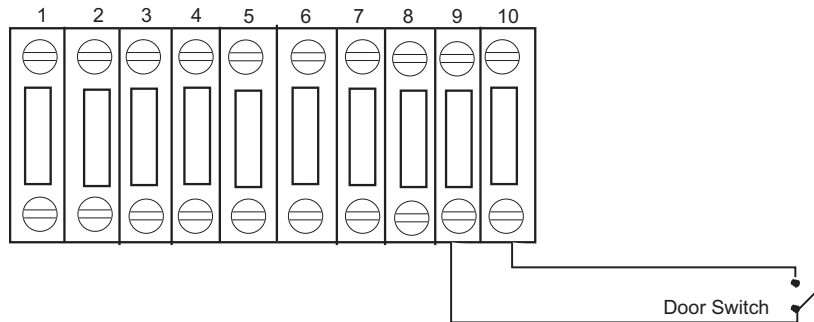


Figure 2-51 With a Door Interlock

Section 10.0 System Ground Connections

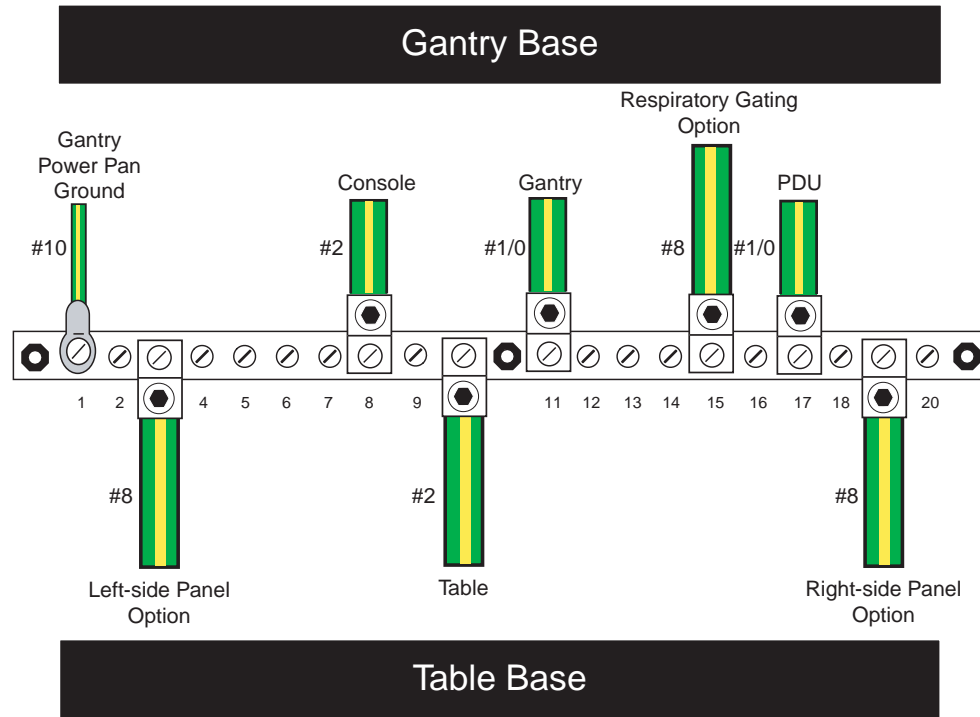


Figure 2-52 Table/Gantry Raceway Bus - Grounds

Various types and sizes of wire are used to ground the system. Please use the type and sizes specified in [Table 2-25](#).

AWG #	Connection To	Connection To	Used on:
#10	Gantry (Power Pan)	Raceway	All
#8	Left-side Panel Option	Raceway	Option
#2	Console	Raceway	All
#2	Table (frame)	Raceway	All
#1/0	Gantry	Raceway	All
#8	Respiratory Gating Option	Raceway	Option
#1/0	PDU	Power Main	All
#8	Right-side Panel Option	Raceway	Option

Table 2-25 System Ground Connections

All connections should be torqued to the values in the chart below:

Wire Size AWG	Bolt/Hex
#14 - 8	6.25 (8.5 N-m)
#6 - 4	12.5 ft-lb (17 N-m)
#3 - 1	21 ft-lb (28.5 N-m)
#0 - 2/0	29 ft-lb (39.3 N-m)

Table 2-26 Ground Torque Values

Chapter 3

System Continuity & Ground Checks



NOTICE Potential for Data Loss and/or Equipment Damage

To prevent potential data loss and equipment damage, please do the following:

- Record data collected from procedures in this chapter into Form F4879 when directed, located in this book.
- Only use the Installation manual that arrives with your system for installation. Any other revisions of this manual may not exactly match your system.

Section 1.0 System Continuity (Mechanical Contractor)

1.1 Time and Personnel

Required Persons	Preliminary Reqs	Procedure	Finalization
1 (FE or mechanical supplier)		20 minutes labor on-site	

1.2 Tools and Test Equipment

- Digital VOM with the capability to read 0.5 ohms
- 30 ft of #18 wire
- 600 VAC meter leads

1.3 Procedure

Reference : [on page 154](#) and : [on page 155](#).



WARNING



USE AND FOLLOW LOCKOUT/TAGOUT PROCEDURES; LOCK OUT WALL POWER.

- 1.) Remove all System Power at the A1 Mains Disconnect Panel. Follow Lockout/Tagout procedures.
- 2.) Put the UPS in the Service Position.
- 3.) Remove the PDU front cover.
- 4.) Verify, with a voltmeter, that mains power is disconnected.
- 5.) Verify that less than 1 ohm of resistance exists between the following ground connections:

FROM	TO	
Wall ground connection	PDU Cabinet	<input type="checkbox"/> Check box when complete

Table 3-1 Mains Connections to PDU

6.) Verify that less than 1 ohm of resistance exists between the following connections:

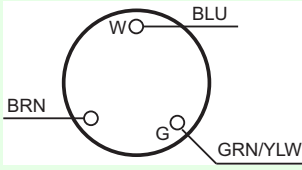
FROM	SIGNAL NAME (COLOR)	TO	
PDU TS2-1	+HVDC (Red)	Gantry HV Power Pan TS1-1	<input type="checkbox"/> Check box when complete
PDU TS2-2	HVDC Ground (Green/Yellow)	Gantry Power Pan Chassis	<input type="checkbox"/> Check box when complete
PDU TS2-3	-HVDC (Black)	Gantry HV Power Pan TS1-2	<input type="checkbox"/> Check box when complete
PDU Ground Bus	HVDC shield	Gantry HVDC cable shield	<input type="checkbox"/> Check box when complete
PDU TS3-1	Axial drive 440vac (Black)	Gantry HV Power Pan TS2-1	<input type="checkbox"/> Check box when complete
PDU TS3-2	Axial drive 440vac (Red)	Gantry HV Power Pan TS2-2	<input type="checkbox"/> Check box when complete
PDU TS3-3	Axial drive 440vac (Orange)	Gantry HV Power Pan TS2-3	<input type="checkbox"/> Check box when complete
PDU TS3-4	Axial drive ground (Green/Yellow)	Gantry Power Pan Chassis	<input type="checkbox"/> Check box when complete
PDU Ground Bus	Axial drive shield	Gantry 440 VAC cable shield	<input type="checkbox"/> Check box when complete
PDU TS5-1	120vac Phase A (Brown)	Console Power Plug: 	<input type="checkbox"/> Check box when complete
PDU TS5-2	120vac Neutral (Light Blue)		<input type="checkbox"/> Check box when complete
PDU TS5-3	Ground (Green/Yellow)		<input type="checkbox"/> Check box when complete
PDU TS5-4	120vac Phase A (Black)	Gantry LV Power Pan TS4-1	<input type="checkbox"/> Check box when complete
PDU TS5-5	120vac Phase B (Red)	Gantry LV Power Pan TS4-2	<input type="checkbox"/> Check box when complete
PDU TS5-6	120vac Phase C (Orange)	Gantry LV Power Pan TS4-3	<input type="checkbox"/> Check box when complete
PDU TS5-7	120vac Neutral (Light Blue)	Gantry LV Power Pan TS4-4	<input type="checkbox"/> Check box when complete
PDU TS5-8	Ground (Green/Yellow)	Gantry Power Pan Chassis	<input type="checkbox"/> Check box when complete

Table 3-2 Resistance Verification Points

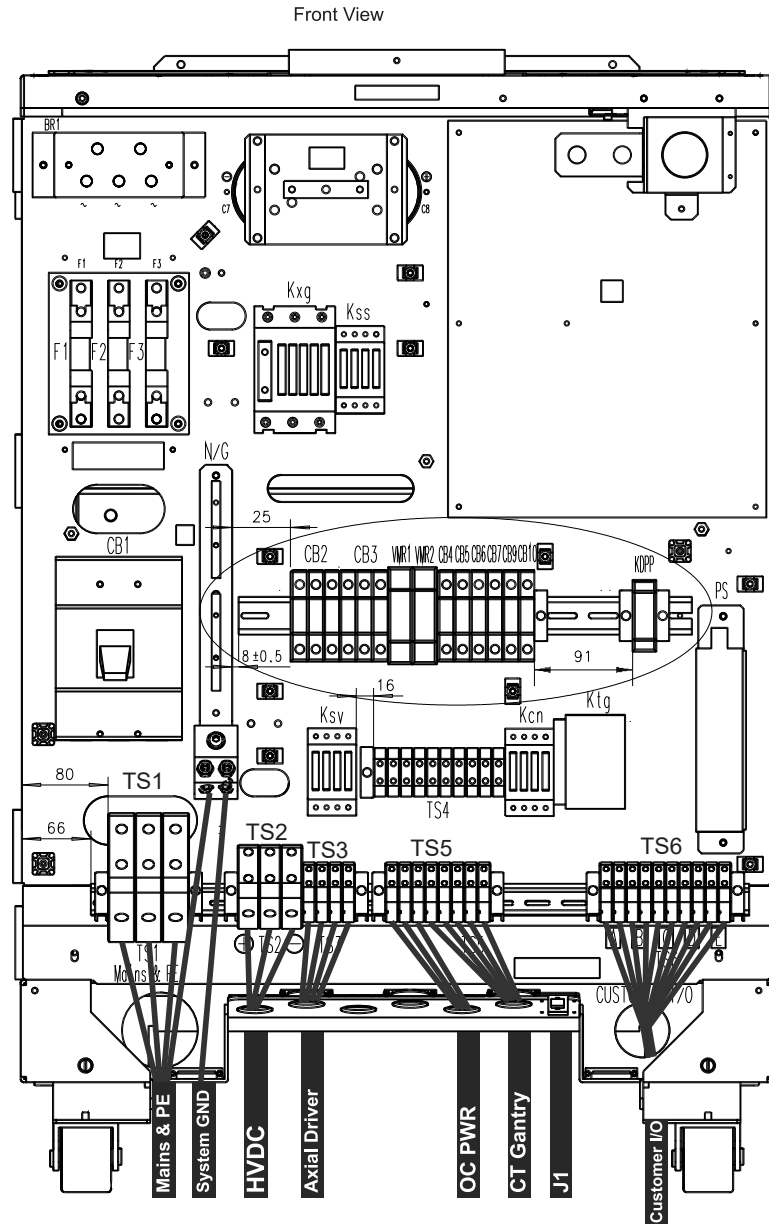


Figure 3-1 Front View of NGPDU, with Covers Removed

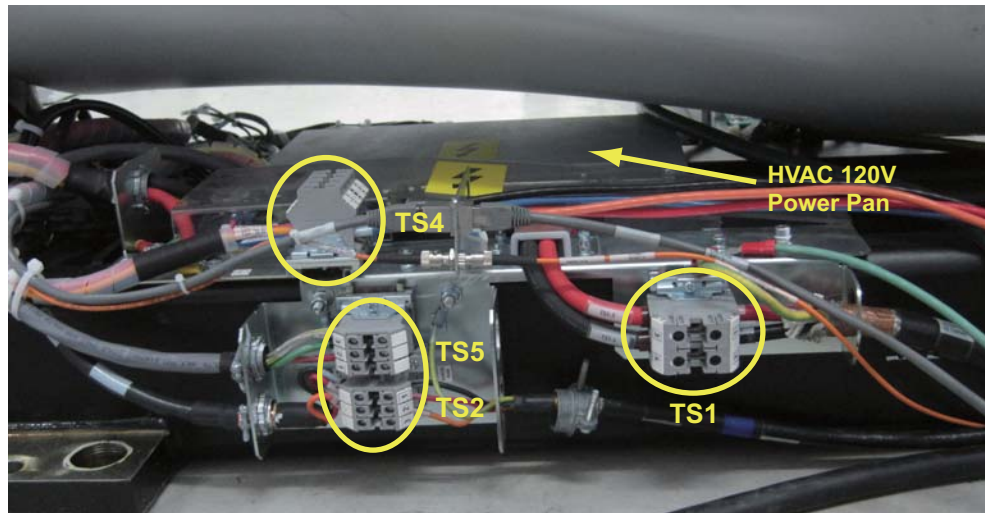


Figure 3-2 Gantry Power Pan

WARNING TURN OFF ALL PDU CIRCUIT BREAKERS.



- 7.) Set an ohmmeter to the lowest scale. Check between the following points for shorts to ground. Verify no continuity exists between the following points:

Table 3-3 No Continuity Verification Points

FROM PDU	TO A1 BREAKER BOX	
TS2-1 (+HVDC) (Red)	vault ground	<input type="checkbox"/> Check box when complete
TS2-3 (-HVDC) (Black)	vault ground	<input type="checkbox"/> Check box when complete
TS3-1 (440vac output) (Black)	vault ground	<input type="checkbox"/> Check box when complete
TS3-2 (440vac output) (Red)	vault ground	<input type="checkbox"/> Check box when complete
TS3-3 (440vac output) (Orange)	vault ground	<input type="checkbox"/> Check box when complete

- 8.) Leave the metal cover off the PDU A3 input power panel until you complete the checks in the next section.

Section 2.0 Site Ground Continuity Check

- 1.) Use an ohmmeter to verify the presence of **less than 1.0 ohm of resistance** between each of the following points:

FROM	TO	
PDU Ground Bus	Vault Ground	<input type="checkbox"/> Check box when complete
PDU Ground Bus	Table/Gantry raceway ground point	<input type="checkbox"/> Check box when complete
Table/Gantry raceway ground point	Gantry Chassis	<input type="checkbox"/> Check box when complete
Table/Gantry raceway ground point	Table Chassis	<input type="checkbox"/> Check box when complete
Table/Gantry raceway ground point	Operator Console Chassis	<input type="checkbox"/> Check box when complete
All Display or Computing Options (if any)	Operator Console Chassis	<input type="checkbox"/> Check box when complete

Table 3-4 Resistance Verification - Site Ground

- 2.) Install remaining covers on:
- Gantry
 - Table
 - Raceway
 - Console
 - PDU

Section 3.0 Shim Installation

3.1 Time and Personnel

Required Persons	Preliminary Reqs	Procedure	Finalization
1 (FE or mechanical supplier)	10 min.	15 minutes labor on-site	5 min.

3.2 Tools and Test Equipment

- Standard FE Tool Kit
- Shim Kit

NOTICE Understand and Follow All General Table Safety Procedures.



3.3 Preparation

Check head holder for a tight fit. If the head holder fit is loose, follow this procedure and shim for.

- Axial head holder
- Foot extender
- Phantom holder

Introduction:

- Some Axial Head Holders have a large free-play in the horizontal direction which could potentially lead to motion and therefore image artifacts.
- Installation of the 2327335 rubber shim kit can minimize this motion.

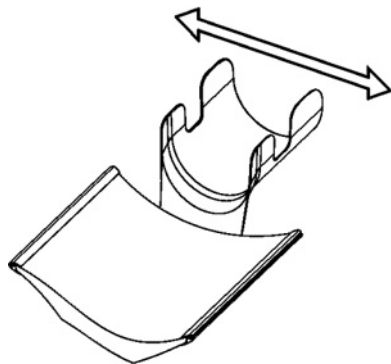


Figure 3-3 Axial Head Holder

Notes before Selecting Shim Thickness:

- While selecting the best shim size, do not attach the rubber shim yet using the adhesive on the back. It is best to use a piece of tape to hold on the shim in order to see if the size is correct.
- Selecting a shim size that is too thick may result in:
 - Difficulty latching the head holder properly. The head holder must latch so that a patient is not injured.

- Damage to the plastic latch or the plastic screws that secure it.

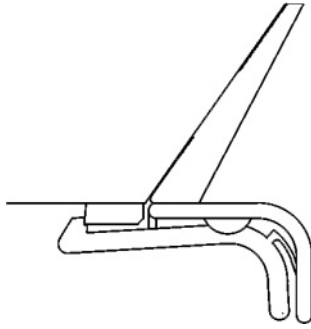


Figure 3-4 Correct - Head Holder is latched onto first step of plastic latch mechanism (The head holder does not need to be latched onto the second step)

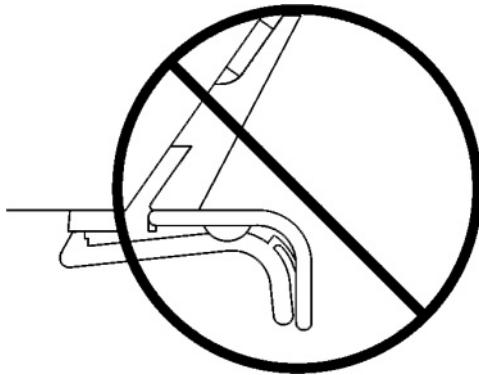


Figure 3-5 Wrong - Head Holder is NOT latched after installing shims

3.4 Procedure

- 1.) First place the two 4.0mm shims (thickest size) onto both edges of the head holder as shown (use a piece of tape to temporarily secure them)
 - The shim must be placed with the tab facing out
 - The thickness is printed on the shim

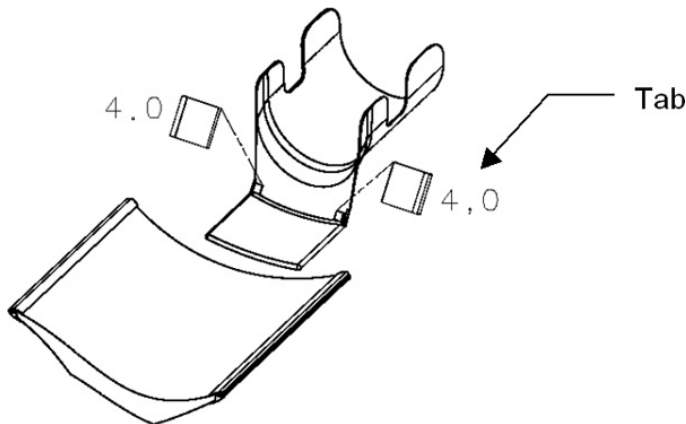


Figure 3-6 Headholder Tab

- 2.) Insert the head holder into the cradle
- 3.) Check if the head holder is latched onto the cradle at the first step of the plastic latch

mechanism. (The head holder does not need to be latched onto the second step)

- 4.) Check if the head holder has a small free-play in the horizontal direction

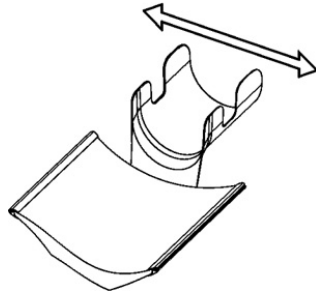


Figure 3-7 Axial Head Holder

- 5.) If the rubber is too thick, repeat steps 1-4 using a thinner shim (3.5, 3.0...0.5mm) until the head holder is latched (without excessive force) and fits securely in the cradle.
If the thinnest shim (0.5mm) is too tight, the tab can be cut off to reduce the thickness

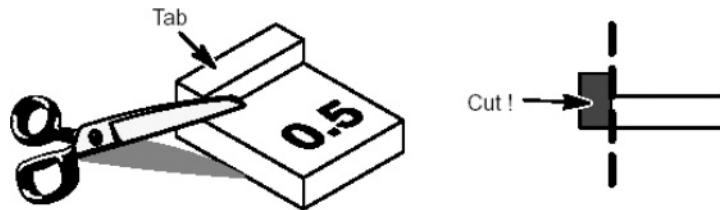


Figure 3-8 Cut the shim for Headholder

- 6.) Clean off the surfaces where the shims will mount using alcohol.
- 7.) Peel off the paper from the back of the selected shims and attach with the tabs facing out. Hold each shim with your fingers for a few seconds to attach it to the head holder.

3.5 Finalization

Review latching of head holder with customer after installation

Section 4.0 LB Tube Label Installation

LB Tube label (5790196) exist in shipping collector.

4.1 Procedure

- Please find the LB Tube label (5790196) from shipping collector and adhere these two labels onto PDU and main power switch panel before powering on system.

5790196



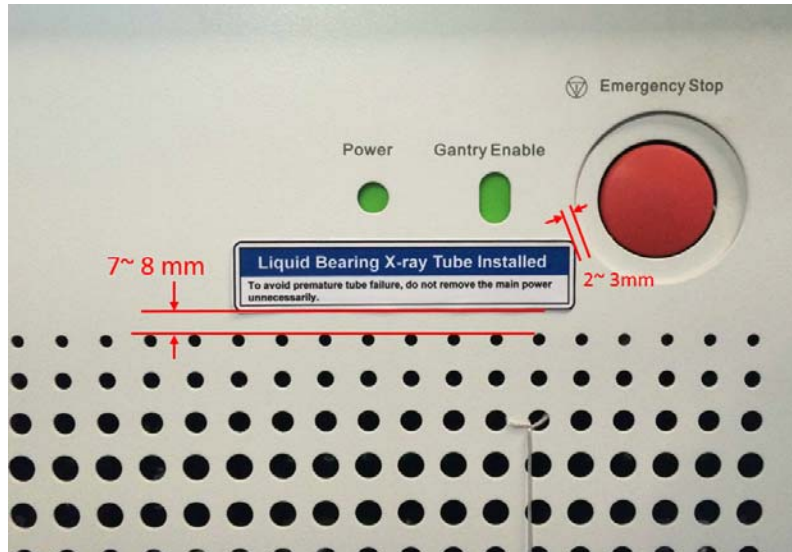
- The following photos show a representative example of each label. See the label description above each photo, for the total number of labels of that type, and any other information concerning that label type.
- Clean the area where the label will be applied with isopropyl alcohol.

4.1.1 Label of PDU and Main Power Switch Panel

5790196 - Need stick on two places, one is used on PDU front panel, the other one stick on the front of main power switch panel.

Note: This is a collector of multi-language labels, sample shown is in English, FE MUST select the label in appropriate language to stick.

- 1.) Stick one label 5790196 on PDU front cover. (Please select the label in appropriate language to stick)
Stick the label on PDU location as shown below, right side of label should have a gap of 2~3mm from the edge of Emergency Stop round area.



- 2.) Stick another label 5790196 on main power switch panel.
Select appropriate language label 5790196 for your customer site.
Stick the label on main power switch panel location as shown below (example), it should be just below (and near to) power switch so that it can be easily noticed by user.



- 3.) Extra labels are not installed on the system and can be discarded.

Chapter 4

System Covers: Installation & Alignment

Section 1.0 Process Overview

Cover install process overview:

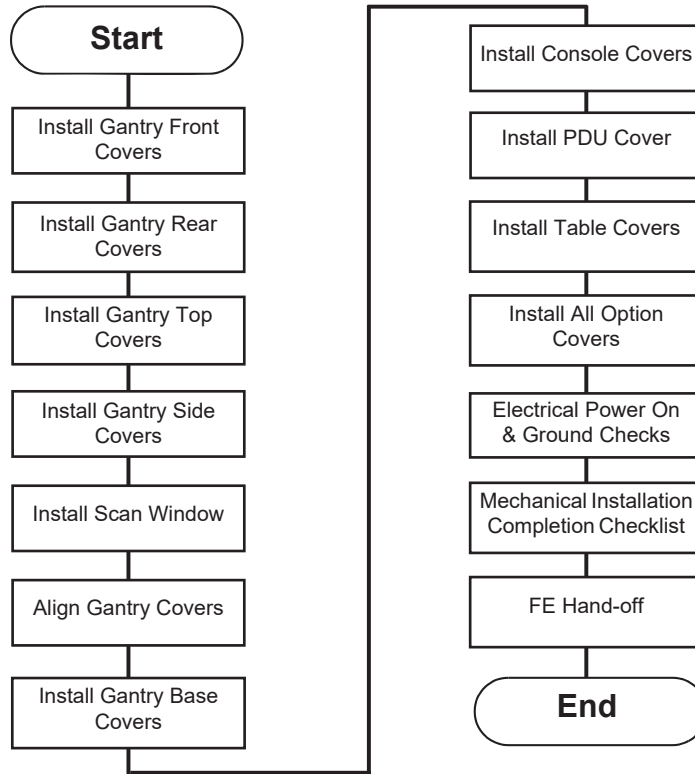


Figure 4-1 Cover Installation Flowchart

1.1 Gantry Front Cover Installation

Refer to [Appendix A](#) for the detailed procedure.

- 1.) Move the gantry to the vertical position and the front cover next to the gantry.
- 2.) Lift the cover onto the stud and attach the front cover:
- 3.) Remove the dolly; disassemble it and store it safely away for later use.
- 4.) Reattach the cables to the cover.

1.2 Gantry Rear Cover Installation

Refer to [Appendix A](#) for the detailed procedure.

- 1.) Attach the rear cover:

1.3 Gantry Bore Cover Installation

- 1.) With two persons, lift the bore cover and attach it to the gantry stationary brackets. Insert the top of the cover bracket to the gantry stationary bracket first.

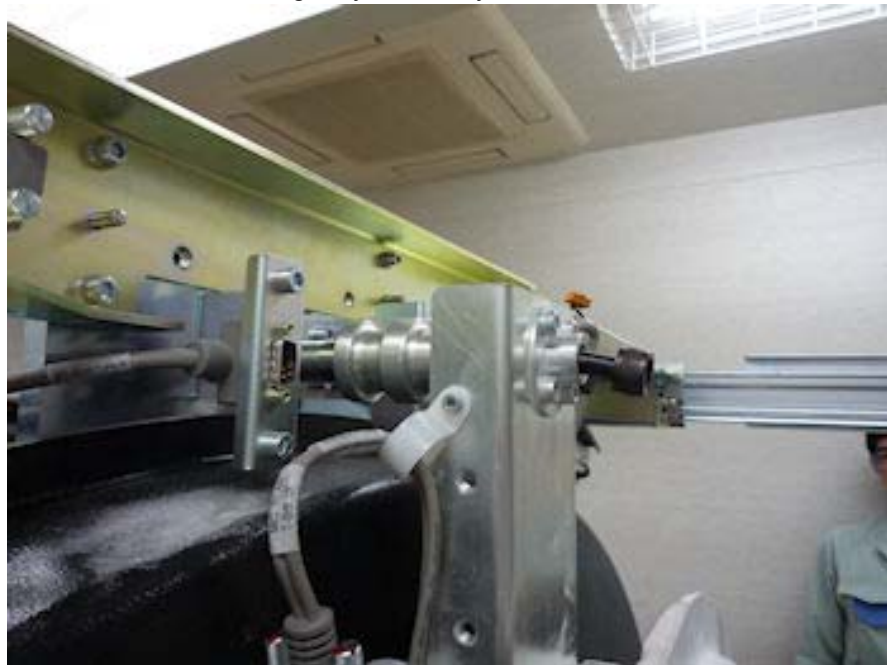


Figure 4-2 Bore Cover Attachment

- 2.) Tighten 3 screws located at top and two bottom brackets of the cover.
- 3.) Connect the Breath Navigator I/F cable and MIC REAR T-SW I/F cable to the connectors.

1.4 Gantry Top Covers

1.4.1 Installation

- 1.) Take one of the top covers and align the tabs on the cover with its associated bracket. Lift and slide the cover into place. Secure the cover using 2 Phillips screws.
- 2.) Repeat the same step for the other side.

1.5 Gantry Side Covers

1.5.1 Installation

- 1.) To install a side cover, place it over the top cover and let the two (2) side cover latches slide behind the metal tabs, located on the top cover.
- 2.) Use hex wrench to secure the side cover to front cover by turning the bolts a quarter turn.

1.6 Gantry Strap Installation

The following procedure is applied if customer requests to install the gantry strap.

- 1.) Cut any tie-wrap and remove two gantry strap from the inside of the front cover.



Figure 4-3 Location of Strap

- 2.) Remove a nylon nut, a spacer and a fastener from the front cover.
- 3.) Relocate the spacer to outside of the front cover, and install the faster, spacer and nylon nut.

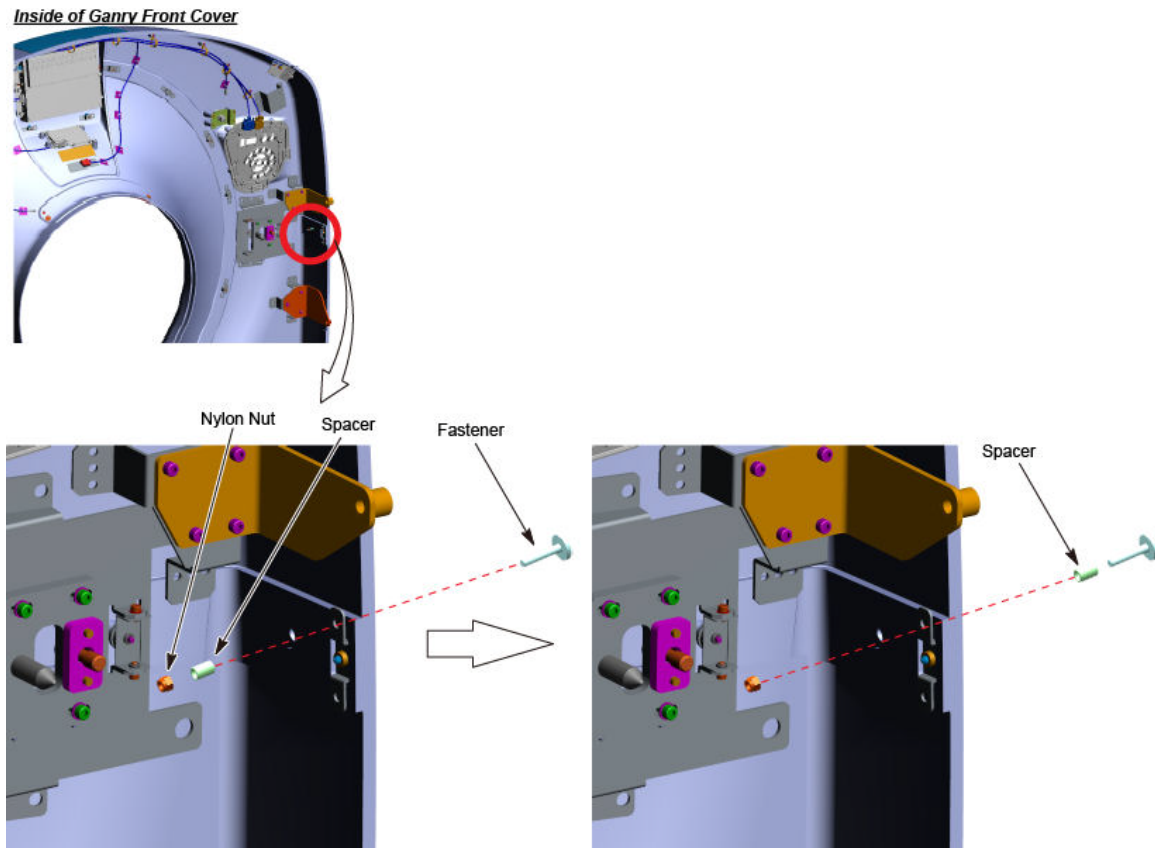


Figure 4-4 Relocation of Spacer

4.) Attach the strap to the fastener.



Figure 4-5 Strap Attachment

5.) In a similar way, install the gantry strap to the other side.

1.7 Scan Windows

1.7.1 Installation

Note: The front and rear covers must be installed before installing the scan window.

- 1.) Shape the scan window as shown in [Figure 4-6](#), and nest the scan window at the bottom of the opening between the front and rear covers, ([Figure 4-7](#)) with the rivets in the 6 o'clock position. Remember the rivets must be in the 12 o'clock position when the mylar window is fully installed.
- 2.) After you complete the initial seating of scan window, let the window slowly unfold, and work both sides of the window into position, starting at the bottom and finishing at the top.
- 3.) Make sure you position the window with the rivets at the 12 o'clock position, and the mylar window slit at either the 3 or 9 o'clock position.

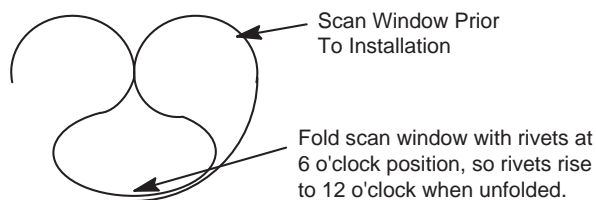


Figure 4-6 Install Scan Window

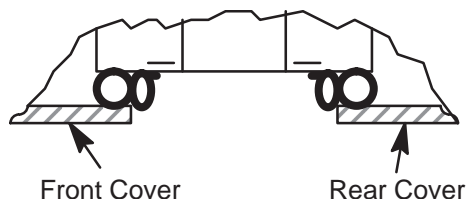


Figure 4-7 Scan Window Nested Between Front and Rear Cover

1.8 Install Gantry Base Covers

1.8.1 Tools Required

3mm and 8mm hex wrenches

1.8.2 Procedure

Assembly Sequence

- 1.) Position cover item 5 on gantry base with bracket slots aligned to gantry holes. Center Cover left to right and attach with (4) hardware Items 16, 2, 3 as shown and tighten.
- 2.) Assemble (2) Bulkheads (Item14) to (2) Brackets (Item 13) using (4) Hardware Items 3 & 4. Assemble (2) Brackets (Item 10) and (2) Brackets (Item 13) to Gantry Base using (8) Hardware Items 1, 2 & 3. Finger tighten hardware with bracket moved outward to end slots (Item 10). Install side covers (Item 6 & 7) on properly aligned with front cover. Remove side covers, tighten fasteners and replace side covers using hardware (1) Item 16, & 2, & 3, and (2) Item 15 on each cover and tighten.
- 3.) Assemble last Bracket (Item 11) loosely to gantry base with (2) hardware Items 1, 2 & 3. Install rear cover (Item 8) to base properly aligned to side cover (Item 6). Attach rear cover to bracket with hardware Items 1, 2 & 3 tightening all fasteners. Lock latch.
- 4.) Place cover Item 9 on gantry base aligned to covers 8 & 9. Lock both latches.

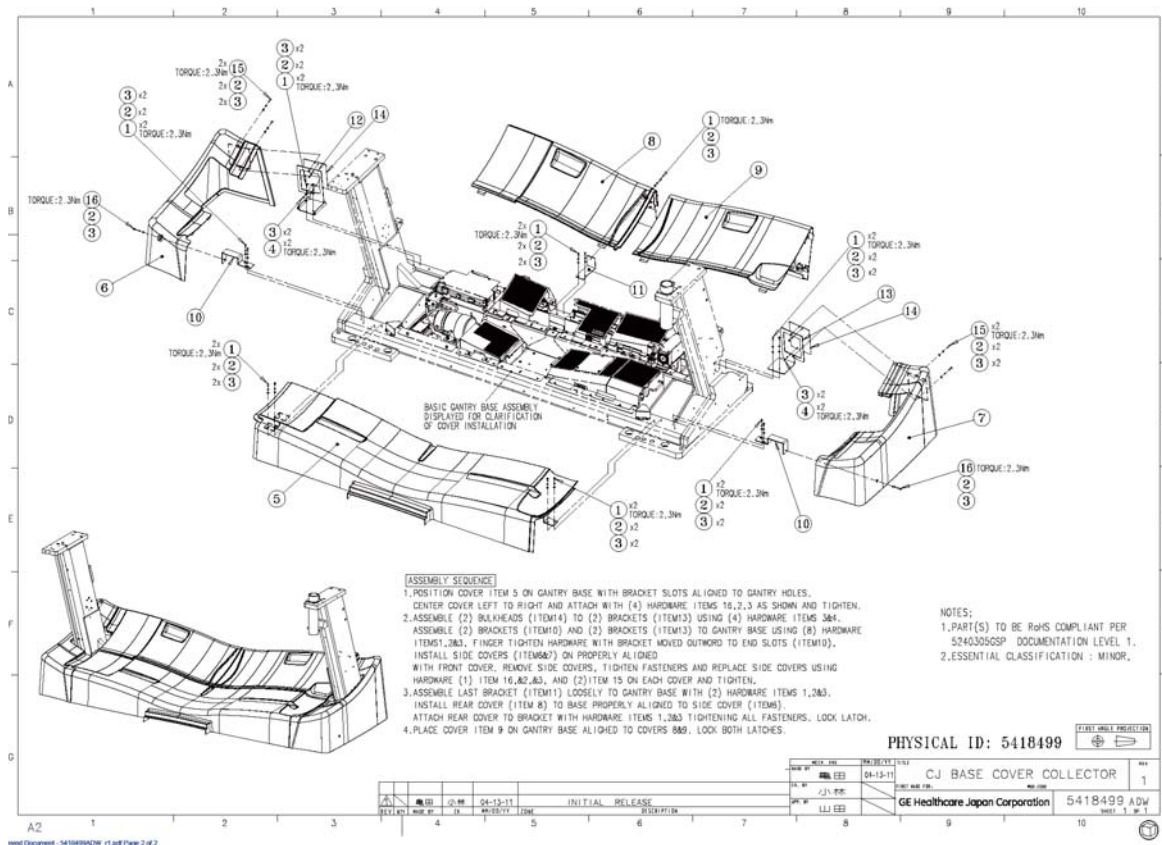


Figure 4-8 Gantry Base Covers Installed

1.8.3 Footswitch Covers Installation (GT1700V)

- 1.) Install the footswitch cover using three (3) screws (see [Figure 4-9](#)).

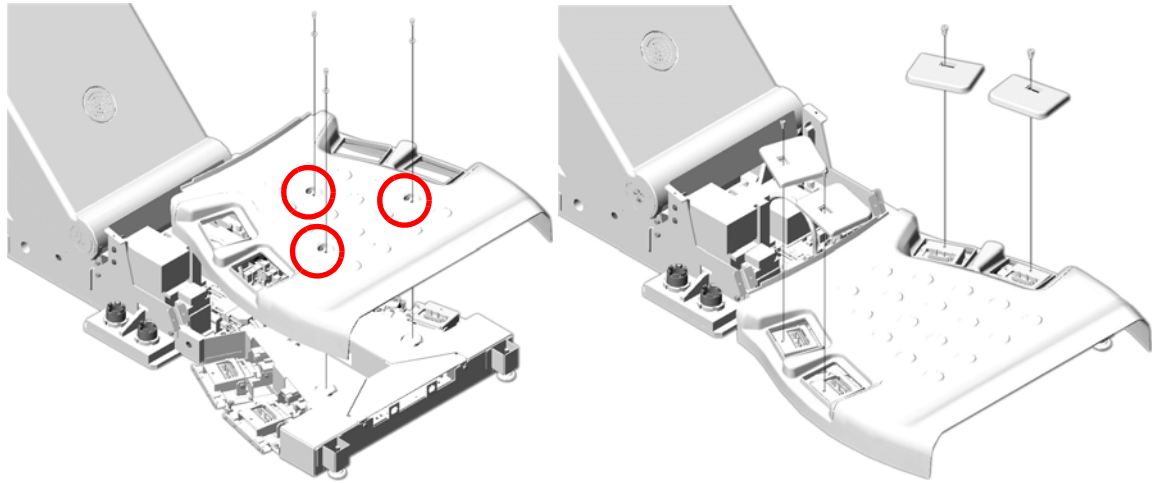


Figure 4-9 Footswitch Cove Installation

- 2.) Install cover caps on each pad.



Figure 4-10 Footswitch Pad Caps

- 3.) Install the four (4) pads onto the footswitch assembly.

Section 2.0 Install Console Covers

2.1 Time and Personnel

Required Persons	Preliminary Reqs	Procedure	Finalization
1 (FE or mechanical supplier)		15 minutes labor on-site	

2.2 Tools and Test Equipment

- 4mm Hex driver

2.3 Procedures

2.3.1 Console Side Covers

- 1.) Swing the side cover into position.
- 2.) Insert top edge of side cover into inside of top cover. The distance between side cover rear edge and chassis should be about 20mm.
- 3.) Move side cover forward and fix it on chassis.

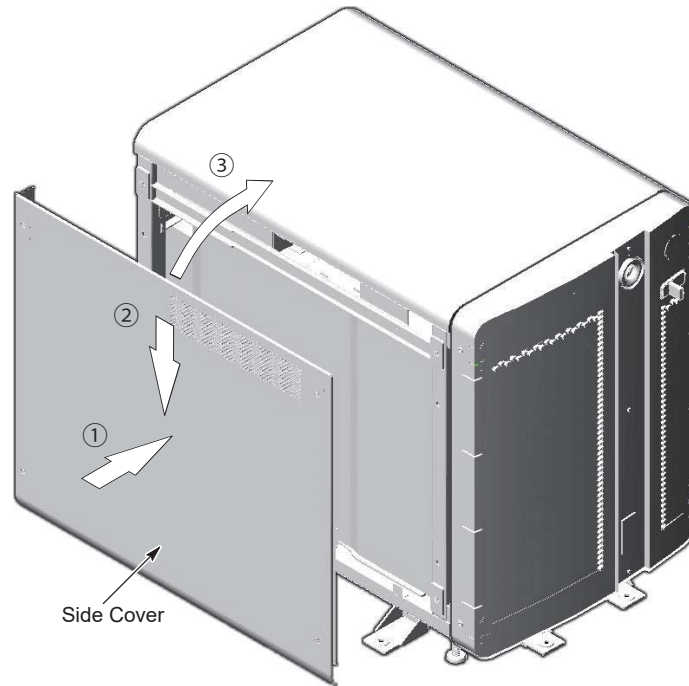


Figure 4-11 Place Side Cover

- 4.) Tighten the four screws at the side cover.

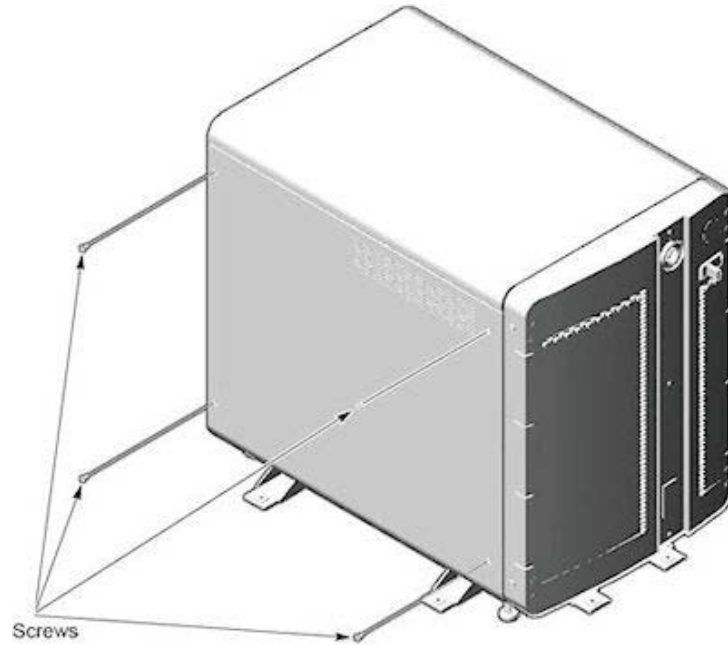


Figure 4-12 Install Side Cover Screws

2.3.2 Console Top Cover

- 1.) Insert two pins of top cover into the hole in the chassis.
- 2.) Slide cover backward and fix cover on chassis.

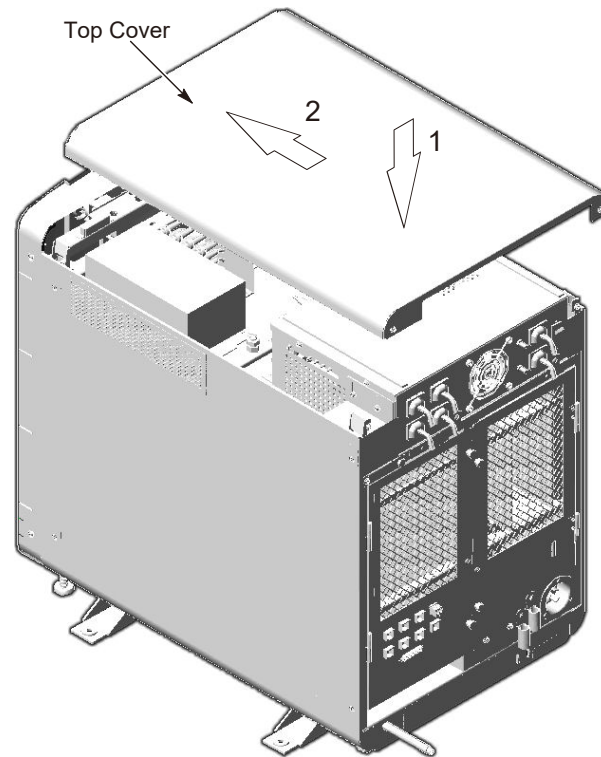


Figure 4-13 Place Top Cover

- 3.) Tighten two screws at behind of top cover.

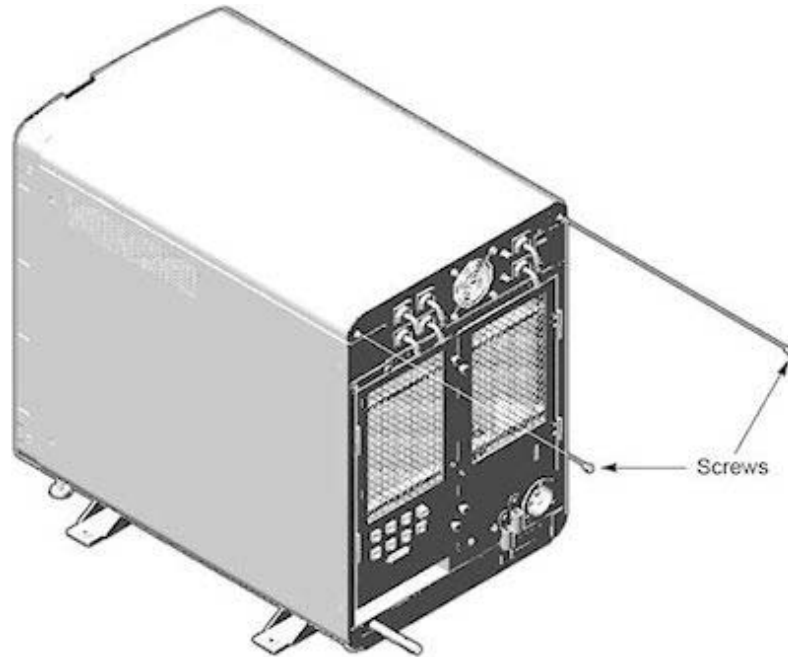


Figure 4-14 Install Top Cover Screws

2.3.3 Console Front Cover

- 1.) Place the front cover onto console.
- 2.) Rotate bottom of cover outward and upward until the cover is placed on the console.

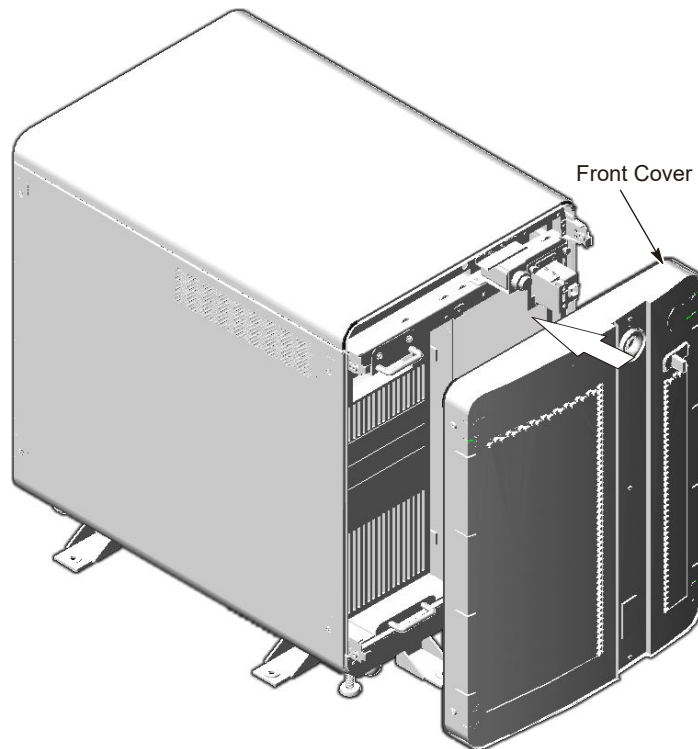


Figure 4-15 Place Front Cover

- 3.) Install four screws (two screws on each side).

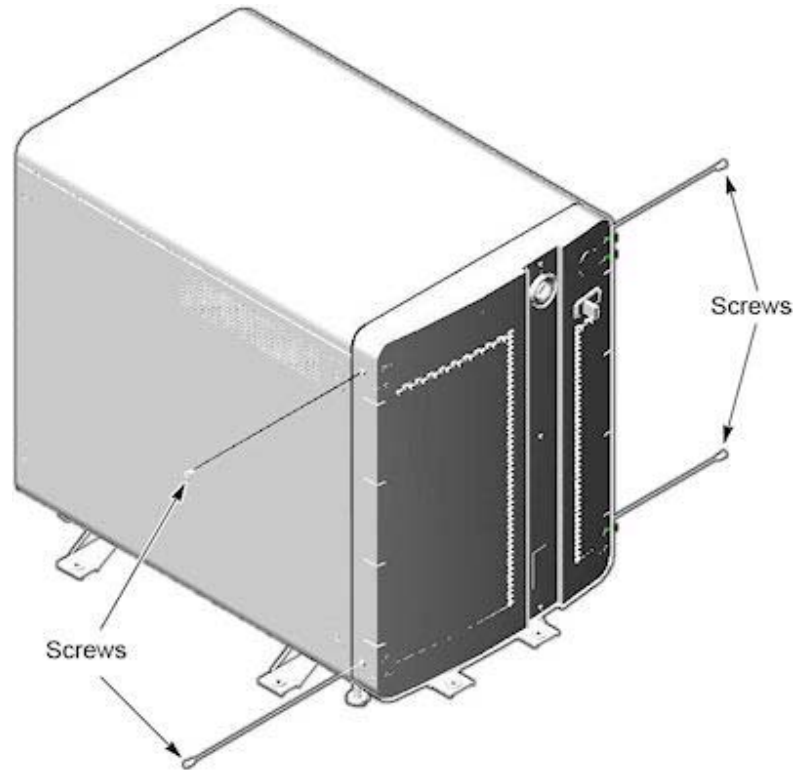


Figure 4-16 Install Front Cover Screws

Section 3.0 Table Cover Installation (GT1700V)

3.1 Side Covers

- 1.) Remove screws (2) on tape switch.
- 2.) Remove back under-side covers (2) plus black screws.
- 3.) Undo the 2 red/black connectors.
- 4.) Remove all six (6) 4mm hex-head screws.

3.2 Install Panels

3.2.1 Top Panel #1

- 1.) Install two (2) 4mm hex-head screws. Leave them loose until the bottom screws are installed.
- 2.) Install 6nd wire using one (1) 4mm hex-head screw.

3.2.2 Bottom Panel #1

- 1.) Install white washer between grey base and panel. Insert Phillips screw into the bushing.
- 2.) Tighten top screws. (Torque 8 lb-in)

Note: Second panel over laps the first panel

3.2.3 Top Panel #2

- 1.) Install two (2) 4mm hex-head screws. Leave them loose until the bottom screws are installed.
- 2.) Install 6nd wire using one (1) 4mm hex-head screw.

3.2.4 Bottom Panel #2

- 1.) Insert white washer between grey base and panel. Insert Phillips screw into the bushing.
- 2.) Tighten Phillips screws. Tighten top screws.

3.3 Re-install Side Panel

- 1.) Install with two (2) Phillips screws. Reconnect cable.

3.4 Table Side Covers Install

- 1.) With the side covers toward table front, align the tabs on the cover with the slots on the table.
- 2.) Slide the cover toward the table until it stops.
- 3.) Slide the cover toward the back of the table to lock the cover in place.
- 4.) Install the two (2) 4mm hex-head screws on each end to secure cover. (1700 Table: Install one (1) screw.)

3.5 Table Side Covers Removal

- 1.) Remove the two (2) 4mm hex-head screws that secure the side cover. (1700 Table: Remove one (1) screw)
- 2.) Slide the cover toward the gantry until the locking tabs disengage and the cover is free.
- 3.) Pull the cover away from the table to remove.
- 4.) Store in a safe place.

Section 4.0 Table Covers Installation (Lite Table)

4.1 Table Base Cover

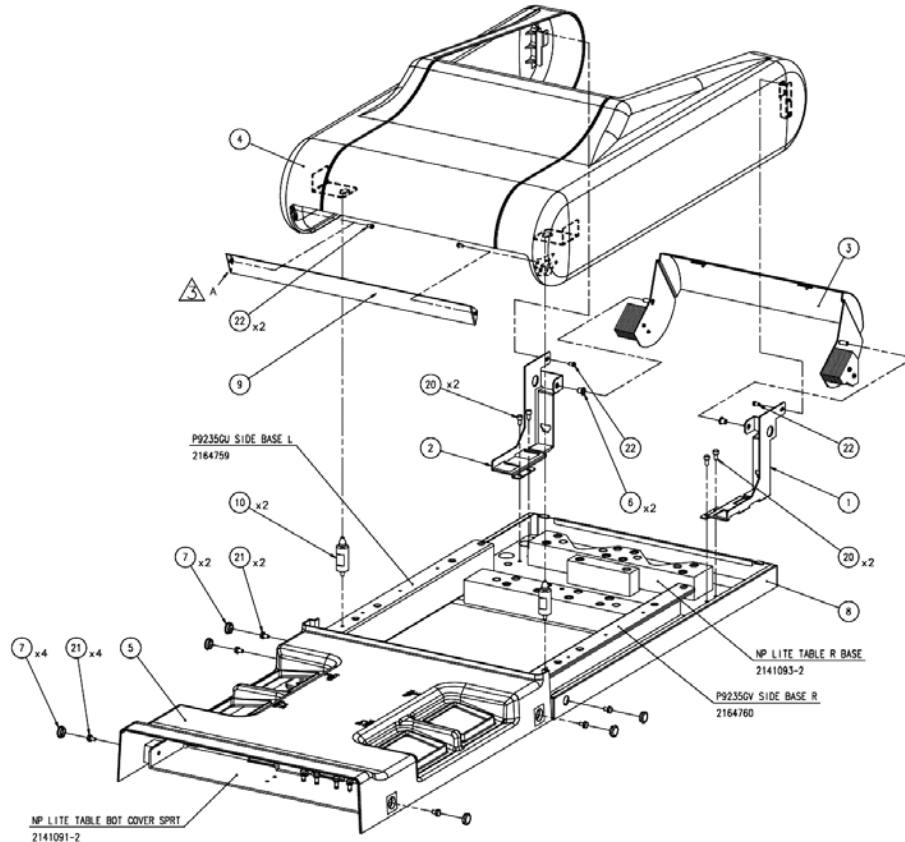
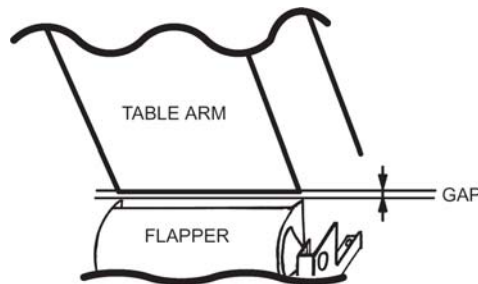


Figure 4-17 Table Base Cover

4.2 Flapper Installation

- 1.) Insert two (2) plastic rings into the left side of flapper and the right side of flapper.
- 2.) Attach two flapper brackets to the flapper.
- 3.) Tighten it to the Table rear bottom by four (4) support bracket screws. There is a gap between the flapper and the table arm as shown in the illustration below. When the flapper is installed on the table base, the left gap and the right gap must be equal using four (4) support bracket screws.



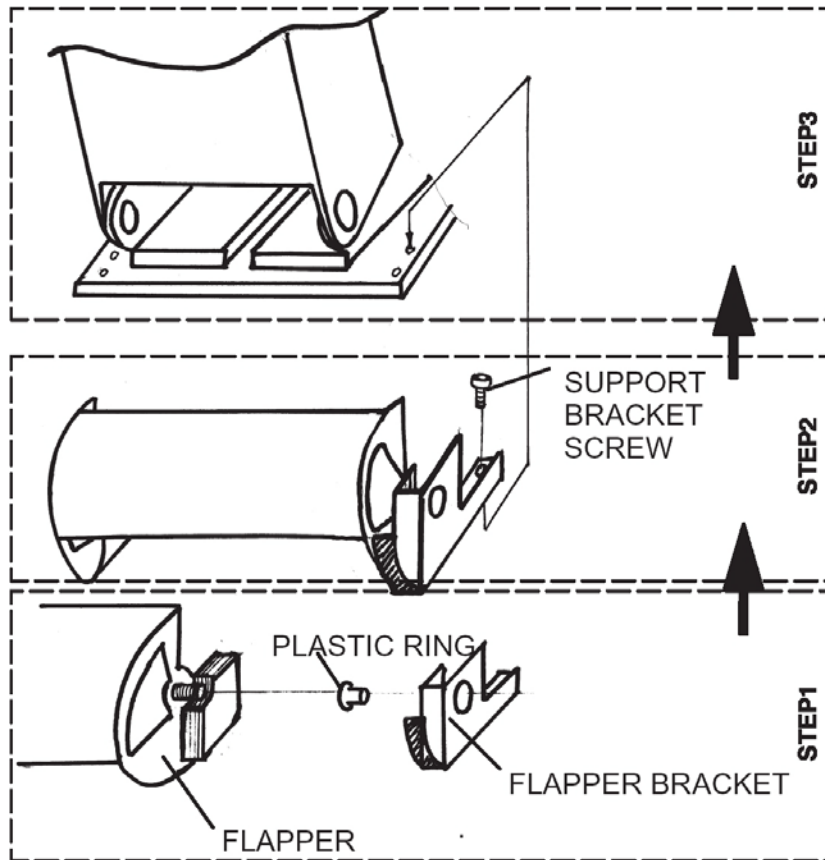


Figure 4-18 Installing the Table Flapper

4.3 Skirt Cover installation

- 1.) Attach Skirt Cover to flapper brackets.
- 2.) Mount Skirt Cover to table bracket with two screws.



Figure 4-19 Installing Skirt Cover

4.4 Bottom cover installation

- 1.) Install the front bottom cover using four screws. After installation, install the screw caps onto the screws.
- 2.) Install the foot switch pedals using four socket screws. After installation, install the screw caps onto the screws.
- 3.) Install the rear bottom cover so that its tabs are aligned with the frame pins.
- 4.) Pull the cover rearwards, then mount it using two screws.
- 5.) After installation, install the screw caps onto the screws.

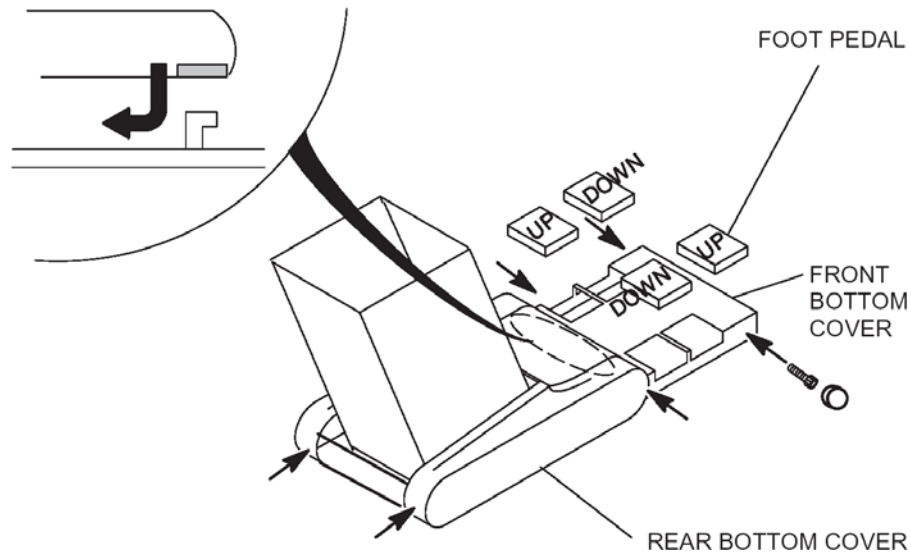


Figure 4-20 Installing the Bottom Covers

Section 5.0 Install All Option Covers

Follow the instructions that came with each of your optional components.

Section 6.0 Electrical Power On & Ground Checks

WARNING



THIS PROCEDURE MEASURES POTENTIALLY HAZARDOUS VOLTAGES. USE AND FOLLOW LOCKOUT/TAGOUT PROCEDURES.

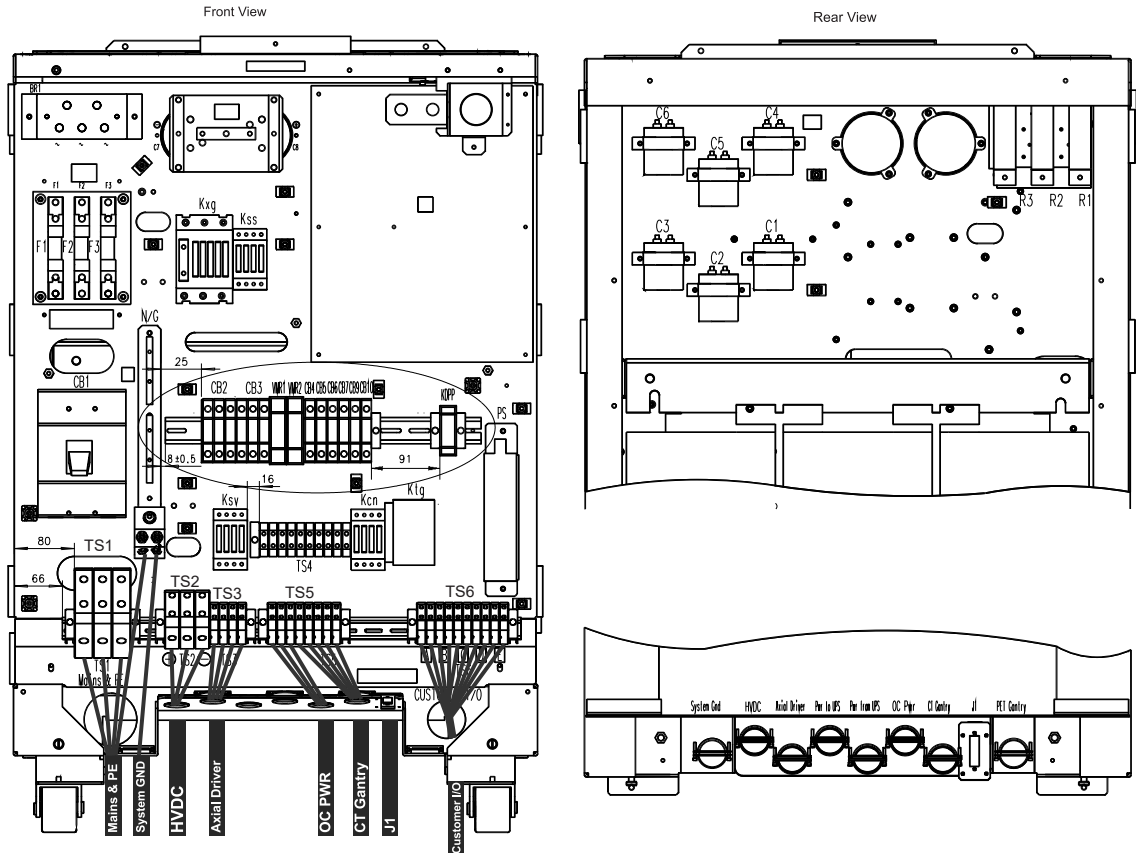
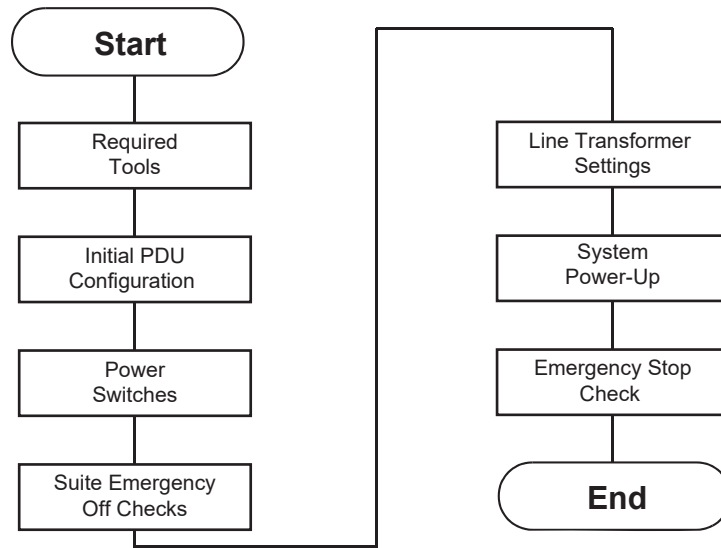


Figure 4-21 NGPDU

6.1 Introduction and Flowchart



6.2 Electrical Power On & Ground Checks Process Overview

6.3 Required Tools

- Multimeter with a rating of at least 1000 volts
- Multimeter leads with a rating of at least 1000 volts

6.4 Initial PDU Configuration

WARNING



THIS PROCEDURE MEASURES POTENTIALLY HAZARDOUS VOLTAGES. USE AND FOLLOW LOCKOUT/TAGOUT PROCEDURES.

6.4.1 Circuit Breakers

Set all PDU, gantry, console, and table circuit breakers to OFF.

6.4.2 Relay Board

- 1.) Set SW 2 to the Auto-Off position.
- 2.) When the system is powered, three lamps should be "ON". (Refer to [Figure 4-22.](#))

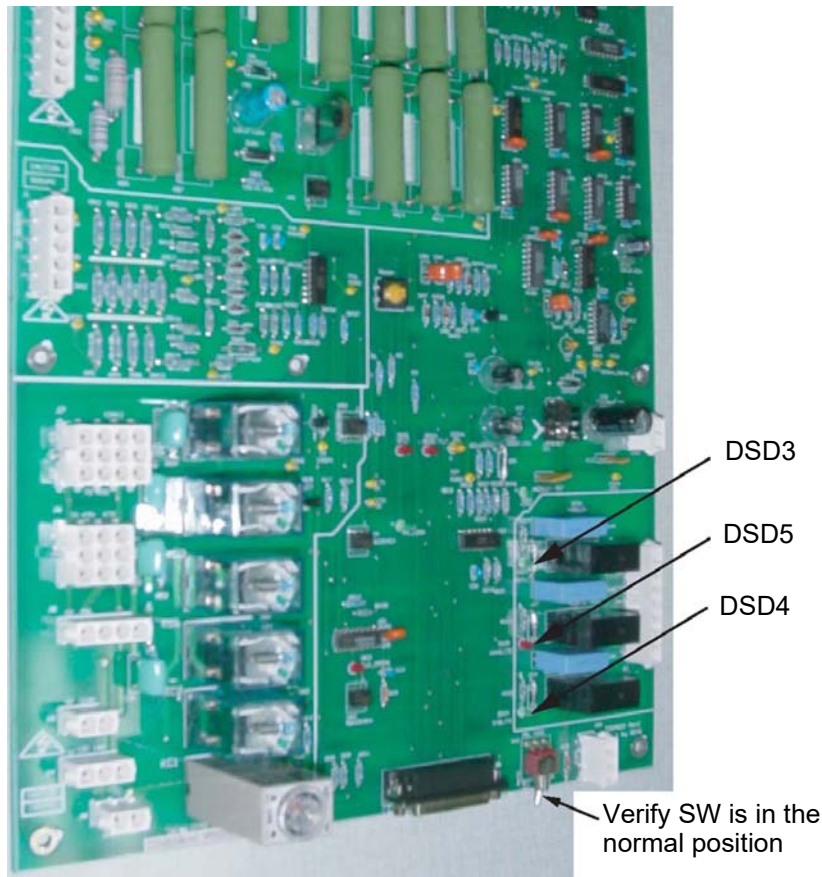


Figure 4-22 NGPDU Control Board

6.4.3 Power Switches

Turn OFF all system power switches at their subsystems.

- Gantry power pan breaker
- All gantry service switches
- Table base power
- Console power



6.4.4 Hardware and Connection Check

Use this step to check mechanical connections and tighten anything that may have shaken loose during shipment. Verify all hardware and connections in the PDU are securely fastened.

- PDU
- Gantry
- Table
- Console

6.4.5 Covers

Install, or verify the presence of, all the lexan safety covers for the PDU.

6.5 Suite Emergency Off Checks SEO

WARNING



ONLY PERFORM THIS PROCEDURE IF YOU ARE USING PROPER PPE. 480 VOLTS MAYBE PRESENT. VERIFY ALL PERSONNEL HAVE CLEARED THE SYSTEM BEFORE YOU TURN ON WALL POWER.

Note:

- 1.) Turn wall power ON to the PDU.
- 2.) **Press the suite emergency off button and verify it turns off wall power to the PDU.**
(Typically, this red palm button is located on the wall close to the console, within the scan suite.)
- 3.) Verify that all "Emergency Off" buttons are working properly.
- 4.) Leave power "OFF".

6.6 Line Transformer Settings

6.6.1 Requirements

- 1.) The PDU is shipped configured for 480VAC.
- 2.) Complete only if your site uses a voltage other than 480VAC.
- 3.) If PDU is configured for 480VAC, go to [6.7](#). Otherwise, proceed to [Section 6.6.2](#).

WARNING



MAKE SURE YOU TURNED OFF, TAGGED AND LOCKED THE MAIN WALL POWER BEFORE YOU CHANGE TAPS. FAILURE TO DISCONNECT POWER AT MAIN INPUT MAY RESULT IN ELECTROCUTION. TURN OFF WALL POWER TO CONNECT OR MOVE METER LEADS, OR TO REMOVE OR INSTALL COVERS. WEAR APPROPRIATE ELECTRICAL PPE.

6.6.2 Line Input Conditions

- 1.) Monitor the No Load Line to Line Voltage at L1, L2, L3, during the workday. Do not record this data during "brown out" conditions.
- 2.) After you determine the nearest nominal line, verify the tap connections match (refer to [Table 4-1](#) and [Figure 4-23](#) for tap locations).

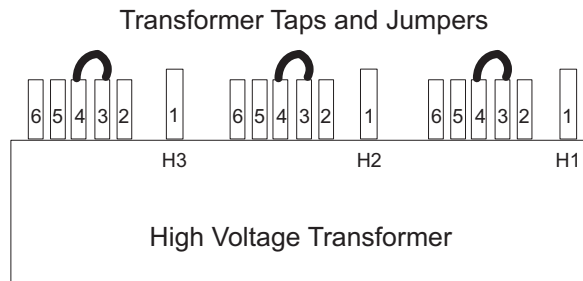


Figure 4-23 PDU Tap Positions (Rear)

Note:

Taps should be shipped as shown for 480 VAC only. For all others, you must move the taps. The tap check should be completed by the mechanical installer.

- 3.) Verify that the No Load Line to Line Voltage never falls outside the corresponding minimum and maximum values listed in [Table 4-1](#).

- 4.) Use a 0-750 AC voltmeter of 3/4% accuracy to measure the line-to-line voltages at L1, L2, & L3.
 - Verify the highest line-to-line voltage does not exceed 1.02 times the lowest voltage.
 - **Example:** If the lowest voltage equals 474, the highest voltage should not exceed $474 \times 1.02 = 483.5$ volts.

WARNING



THIS PROCEDURE MEASURES POTENTIALLY HAZARDOUS VOLTAGES. USE AND FOLLOW LOCKOUT/TAGOUT PROCEDURES.

No Load Line to Line Voltages		Tap Connections (All 3 phases must have same the configuration)		
Nominal	Maximum Range (10%)	Phase A Connection	Phase B Connection	Phase C Connection
480V*	432 to 528*	3-4*	3-4*	3-4*
460V	414 to 506	3-5	3-5	3-5
440V	396 to 484	3-6	3-6	3-6
420V	378 to 462	2-4	2-4	2-4
400V	360 to 440	2-5	2-5	2-5
380V	342 to 418	2-6	2-6	2-6
240V**	216 to 264**	1-4**	1-4**	1-4**
220V**	198 to 242**	1-5**	1-5**	1-5**
200V**	180 to 220**	1-6**	1-6**	1-6**

* Factory Default

** 2326492-3 PDU only

Table 4-1 PDU Line Tap Connections

Record system voltages here:

Phase A: _____ Phase B: _____ Phase C: _____

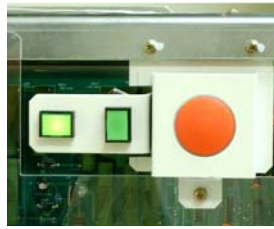
6.7 System Power-Up

CAUTION Verify all personnel have cleared the system before you turn on wall power.

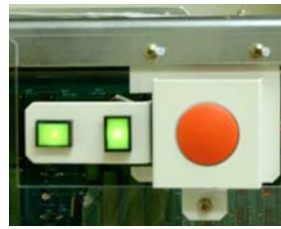
- 1.) Turn ON the A1 breaker panel.

Note: Do not stand in front of the main disconnect to turn on power.

- 2.) Turn ON all system power switches and breakers (PDU, gantry, table, console).
 - All PDU breakers
 - Make sure that the on/off button (on the front PDU panel) is ON for console power.



PDU Power Switch Off



PDU Power Switch On

- Gantry power pan breaker
- All gantry service switches
- Table base power
- Console power (Check internal breaker.)

Note: (16BW45.x or later)
 User Logon screen will appear during system start up.

SUB-SYSTEM POWER-UP

- 1.) Turn ON switch S3 in the table (120VAC 24-hour power).
- 2.) Turn the gantry 120 - 208VAC to ON. (Light should turn on.)
- 3.) Turn AXIAL DRIVE ENABLE ON. (Light should turn on.)
- 4.) Turn HV DC ENABLE ON. (Light should turn on.)
- 5.) Push the Service Switch Panel reset button. (See [Figure 4-24](#))

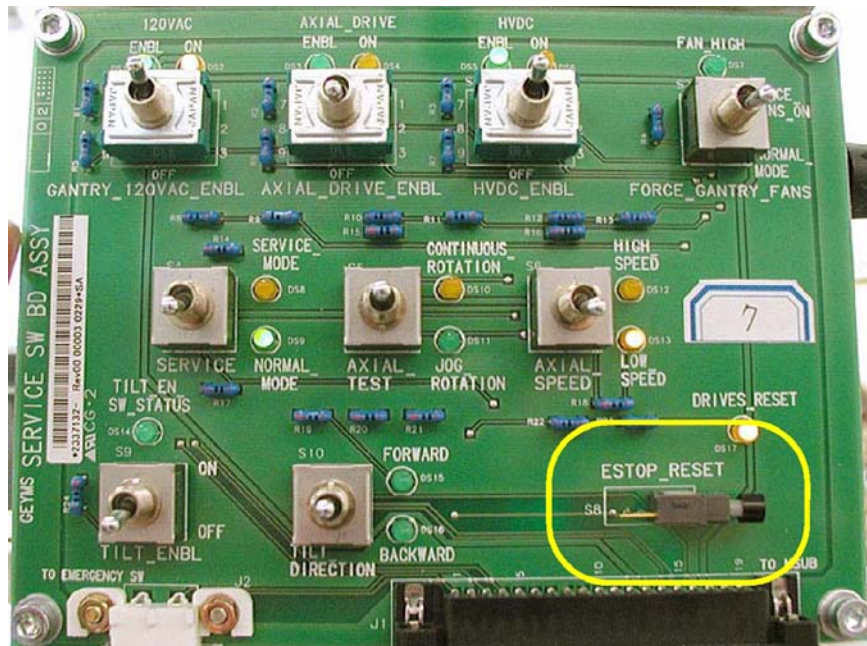


Figure 4-24 Service Switch Panel

AXIAL ENABLE SWITCH TEST

- 1.) Unplug all top cover fan plugs.
- 2.) Turn OFF axial drive enable switch AXIAL_DRIVE on the Service Switch Panel.
- 3.) Clear the gantry area for rotation.

Note: For the initial condition, do NOT leave the tube at the 2:30 position.

- 4.) Press the alignment light push button.
- 5.) Verify that the gantry did not rotate.

ROTATION SAFETY CHECKLIST

- 1.) Manually rotate the gantry 360 degrees.
 - Listen for any interference between the rotating and stationary parts.
(Correct any interference problems.)
 - Listen for any loose parts.
(Tighten parts as needed.)
- 2.) Turn ON all enable switches.

WARNING

MAKE SURE THERE ARE NO OBSTRUCTIONS AROUND THE GANTRY. PRESSING THE ALIGNMENT LIGHT PUSHBUTTON WILL CAUSE THE GANTRY TO ROTATE.

- 3.) Press the alignment light push button.
- 4.) Verify that the gantry rotates.
- 5.) Turn off the laser light.
- 6.) Perform a 2-second X-ray OFF scan.

NOTICE

During the scan, it may be necessary to enter the scan room to obtain a better listening position. If so, keep a finger on one of the four E-STOP buttons (on the gantry), to quickly stop the gantry, if necessary.

- a.) From the console, click on the SERVICE DESKTOP icon.
- b.) Select DIAGNOSTICS.
- c.) Select DIAGNOSTIC DATA COLLECTION
- d.) Set the scan time to 4.00 seconds and rotating X-ray Off.
- e.) Select ACCEPT.
- f.) Leave the door open. (This makes it easier to hear any loose or interfering parts.) The gantry should spin for approximately 45 seconds
 - * Listen for any interference between the rotating and stationary parts.
(Correct any interference problems.)
 - * Listen for any loose parts.
(Tighten parts as needed.)
- g.) After completing the 4-second scan, repeat Step a through Step f, with the following scan times:
 - * 2.0 second scans
 - * 1.0 second scans
 - * 0.7 second scans
 - * 0.5 second scans
- 7.) Confirm all enabled switches are on then install removed covers.

6.8 Install PDU Covers

6.8.1 Time and Personnel

Required Persons	Preliminary Reqs	Procedure	Finalization
1 (FE or mechanical supplier)		10 minutes labor on-site	

6.8.2 Tools and Test Equipment

- Medium +blade screw driver
- Medium -blade screw driver

6.8.3 Procedure

- 1.) Confirm that the plastic safety shield is still in position and secured to the PDU.
 - If it is not, install the shield using the remover hardware.
 - Position the front cover so that the bottom is resting on the two guide pins located on the bottom of the PDU chassis.
- 2.) Raise the cover into place and use the two thumb screws on the top of the front cover to secure it. Screws should be tight, but do not over tighten them.
- 3.) Place the top cover on the PDU.
- 4.) Slide the cover toward the front of the PDU until the cover latches.
 Using a +blade screw driver, tighten the screws. Do not over tighten them.

6.8.4 Emergency Stop Check

- 1.) Use the gantry push-buttons to advance the cradle about 0.5m (2ft) from the home position.
- 2.) Press one of the E-STOP buttons on the gantry.
- 3.) Make sure the TABLE POWER shuts off, and the green LED flashes.
- 4.) Depress one of the table elevation buttons, to verify the emergency stop disabled table elevation.
- 5.) Depress one of the cradle drive buttons, to verify the emergency stop disabled the cradle drive.
- 6.) Press one of the **RESET** buttons to turn on X-RAY DRIVES POWER. (120 VAC LED stops flashing.)
- 7.) Press the other E-STOP button on the gantry.
 - a.) Make sure the Table Power shuts off.
 - b.) Manually move the cradle to the home position to make sure the cradle clutch released.
 - c.) Make sure the cradle latches securely in the home position.
- 8.) Press one of the **RESET** buttons to turn on X-RAY DRIVES POWER.
- 9.) Press one of the four table tape switches to make sure the table down motion stops. Repeat with the three remaining table tape switches.
- 10.) Press the console emergency stop switch; make sure the Table Power shuts off.
- 11.) Press one of the **RESET** buttons to turn on X-RAY DRIVES POWER. (See [Figure 4-25](#)).



Figure 4-25 Reset buttons on Gantry Switch

Note: Emergency Stop buttons are located on the front of the gantry (2 in all), as noted in [Figure 4-26](#). Additionally, emergency stop buttons are provided on the Operator Console GSCB and PDU (see [Figure 4-27](#)).



Figure 4-26 Gantry Emergency Stop Button Positions



Figure 4-27 GSCB Emergency Stop Button

Section 7.0 Mechanical Installation Completion Checklist

System-Level

- FE Service cabinet moved to the location shown on the site print
- All covers installed and aligned
- All options installed on the table and gantry
- All packing materials and boxes returned to the lean cart
- All service items placed in the service cabinet.

Optional and Regional

Seismic mounting installed, if required in your area.

Site Clean Up

- All customer items placed on a cabinet or on a counter and labeled customer material.
- All system service tools placed in the GE service cabinet.
- System software and options left on the lean cart in the software tray
- System cleaned and nicks repaired
- Installation site cleaned and all trash properly disposed.

Dolly Return

- Return of dollies and lean carts arranged for and pick-up made.

Paperwork

- Mechanical installation section of the GE Form e4879 completed
 - √ Room information recorded on the GE Form e4879
 - √ Table gantry alignment completed per the installation manual
 - √ Table gantry anchoring completed per the installation manual
- GE Healthcare personnel notified that the mechanical installation is completed
- All installation issues have been addressed and or documented so FE can follow-up as needed.

This Page Intentionally Blank.

Appendix A

Gantry Cover Removal and Dolly Setup

Section 1.0 Gantry Cover Removal

NOTICE Follow ALL required safety and PPE procedures customary for your organization, when working on this product.

1.1 Time & Personnel

Required Persons	Preliminary Reqs	Procedure	Finalization
1	Not Applicable		

1.2 Tools and Test Equipment

- Front and rear cover dollies
- Hex wrench set

1.3 Procedures

1.3.1 Gantry Scan Window



CAUTION Potential for Equipment Damage. The cones of the front and rear gantry covers must be aligned within specification to ensure proper scan window fit. If the scan window is not fit properly, fluids can get into the collimator and detector, causing image artifacts or permanent damage.

This procedure assumes the front and rear covers are installed.

- 1.) Grab the window at the top and pull firmly downward.
- 2.) Pull the scan window down from the top center and then grasp both sides of the scan window, move them together and lightly pull upward, until you can free the window from between the front and rear covers. See Figure A-1.

Note: You may need to use the tip of a flat blade screwdriver to pull down the top edge of the scan window away from the cover in order to grab it with your fingers. Be careful not to push the screwdriver in too far as the gasket can be damaged.



Figure A-1 Scan Window Removal

1.3.2 Side Cover Removal

- 1.) If removing side cover in preparation for front cover removal, move the table to its lowest position before powering off gantry.

CAUTION



Shock Hazard
Voltage Present
No service on left side while energized.

- 2.) Use an 8mm Hex wrench to unlatch the side cover from the front cover. See [Figure A-2](#).

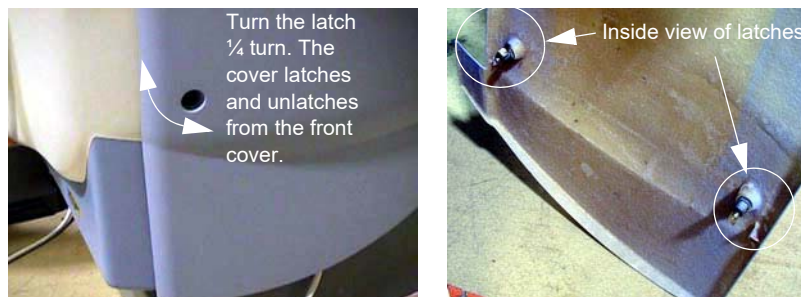


Figure A-2 Side Cover Latches

- 3.) Remove the right side cover by lifting it upward to release the two (2) latches, located on the top edge of the cover. See [Figure A-3](#). Once removed, the service switches should be exposed.

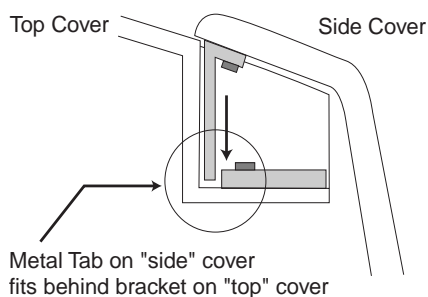


Figure A-3 Side and Top Cover Clasp

- 4.) Turn OFF the three (3) main power switches (HVDC, 120VAC, and Axial Drive) on the Service

Switch Panel (SSP) as applicable for the service being performed. See [Figure A-4](#).

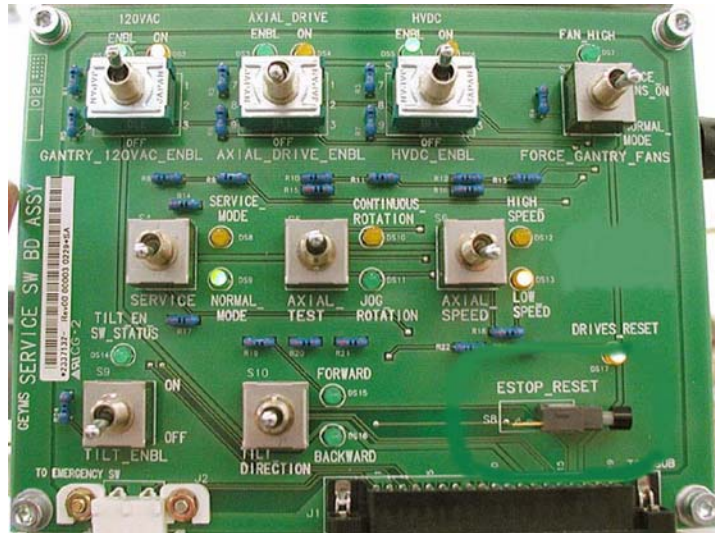


Figure A-4 Service Switch Panel

5.) Repeat Steps 1 and 2 for the left side cover.

1.3.3 Top Cover Removal

CAUTION Potential for Shock.



Voltage may be present. Potential for injury if covers removed and power is left ON. Always remove the right side cover first, and turn OFF power at the service switches.

1.) Remove the gantry right side cover.

NOTICE



Always turn OFF the HVDC before the 120 VAC. Turning OFF 120 VAC power before HVDC power can result in equipment damage.

2.) Turn OFF the three (3) main power switches (HVDC, 120VAC, and Axial Drive) on the Service Switch Panel (SSP) as applicable for the service being performed. See [Figure A-5](#).

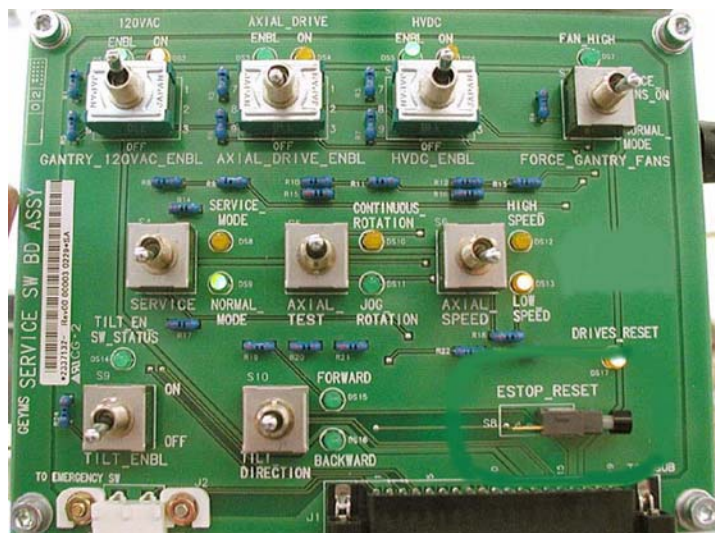


Figure A-5 Service Switch Panel

- 3.) Unscrew two screws that secure the top cover with Philip top screwdriver.



Top cover
Screws

Figure A-6 Screws Securing Top Cover

- 4.) Take the end of the top cover nearest to the side cover and tilt upwards.
- 5.) Slide the cover down to disengage the tab from the mounting bracket.



Figure A-7 Top Cover Tabs and Bracket

- 6.) Lift the cover clear and repeat the above steps for the other cover.

1.3.4 Gantry Front Cover

NOTICE Potential for cover damage.



Front and rear cover removal and installation can be safely accomplished by one (1) person using the dollies provided with the system. Failure to use these dollies will significantly increase the likelihood of damage to the covers. Do not lean covers against walls.

Front Cover Dolly Setup

DANGER



EQUIPMENT TIP HAZARD

DO NOT USE DOLLIES ON UNEVEN SURFACES SUCH AS STEPS OR ELEVATOR THRESHOLDS. THE DOLLIES ARE DESIGNED TO BE USED ON FLAT LEVEL FLOORS WITHIN THE SCANNING SUITE ONLY. MISUSE CAN RESULT

**IN PERSONAL INJURY OR DAMAGE TO COVERS OR OTHER FACILITY ITEMS.
ONLY USE DOLLIES ON FLAT SURFACES..**

CAUTION



Rotating arms on the stand are supposed to be stiff. If they fall freely, tighten the tensioning nuts. Loose rotating arms will reduce the stability of the dollies when supporting the front cover. Do not lubricate.

- 1.) Arrange Dolly sections for assembly. The base and post can be assembled only one way.
Refer to [Figure A-8](#) and [Figure A-9](#).
 - The base uses two (2) palm screws to clamp the four (4) legs in the open or usage mode.
 - The base also uses the same palm screws to prevent the legs from falling in storage mode.
 - The top post can be inserted in either base and is keyed for proper engagement.
 - The top post locking pin prevents the sections from separating during usage.

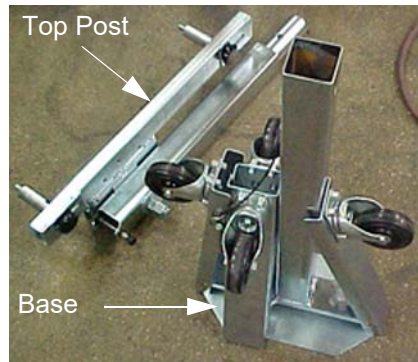


Figure A-8 Front Cover Dolly in Storage Mode

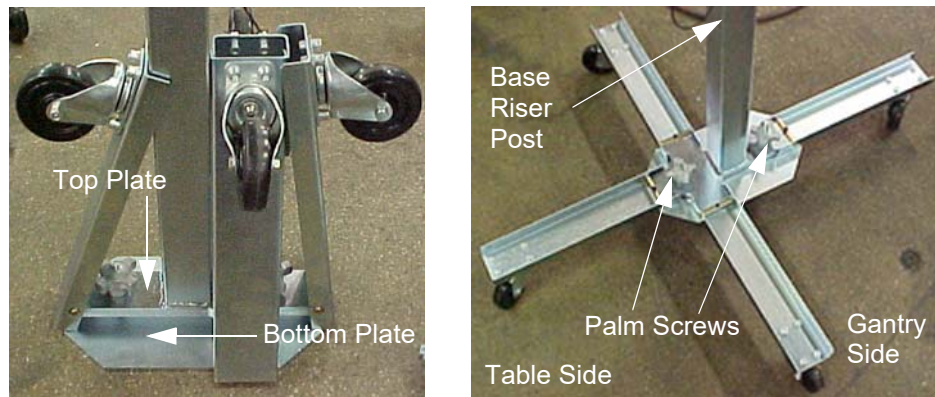


Figure A-9 Front Cover Dolly Base Assembly

- 2.) Unfold the base legs by loosening both palm screws to the top of their travel.
- 3.) Carefully unfold the legs so that the castors touch the floor.
- 4.) Tighten the palm screws to clamp the legs between the base top and bottom plates.

Note:

Lifting the base by the riser post while leaving the castors on the floor will ease palm screw tightening. Reference [Figure A-9](#).

WARNING



**EQUIPMENT TIP HAZARD
COVER DOLLIES MAY TIP OVER IF NOT CONFIGURED PROPERLY.
ENSURE BOTH PALM SCREWS ARE TIGHTENED SECURELY AND THE LEGS
ARE CLAMPED TIGHTLY BETWEEN THE BASE TOP AND BOTTOM PLATES.**

FAILURE TO DO SO WILL RESULT IN INSTABILITY DURING FRONT COVER HANDLING.

- 5.) Insert top post into the base riser post. Align the key for complete engagement.
- 6.) Insert top post locking pin to secure both top and bottom sections.
- 7.) Reverse above steps to disassemble.

Note: For base storage only one (1) palm screw needs to be tightened. This will engage the bottom base plate and the leg ends preventing the legs from unfolding during transport and storage.

Removal

- 1.) Position the table at its lowest position.

NOTICE

Always turn OFF the HVDC before the 120 VAC. Turning OFF 120 VAC power before HVDC power can result in equipment damage.



- 2.) Remove gantry side and top covers, if you have not already done so.
- 3.) Verify the three (3) power switches have been turned OFF (see Figure A-10).

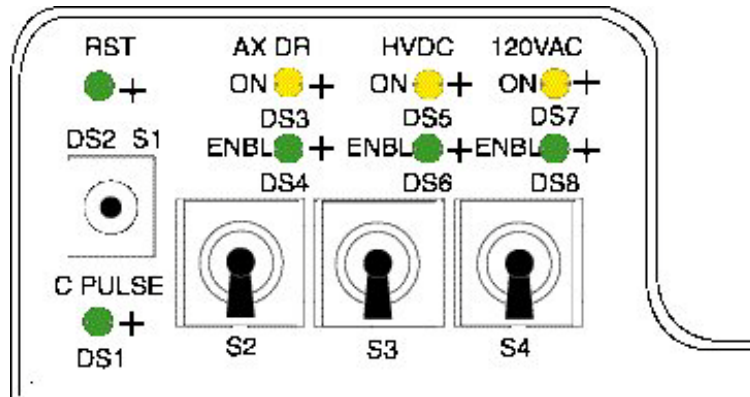


Figure A-10 STC Power Switches

- 4.) Verify the three (3) power switches have been turned OFF (see Figure A-11).

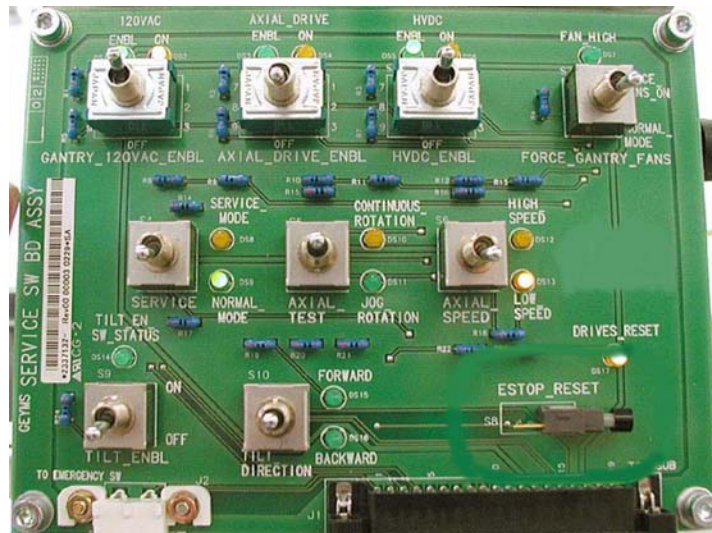


Figure A-11 Service Switch Panel

- 5.) Assemble the front cover dolly.
 - a.) Tighten the two (2) shoulder bolts to the gantry securely. This makes cover installation easier (see [Figure A-12](#)).

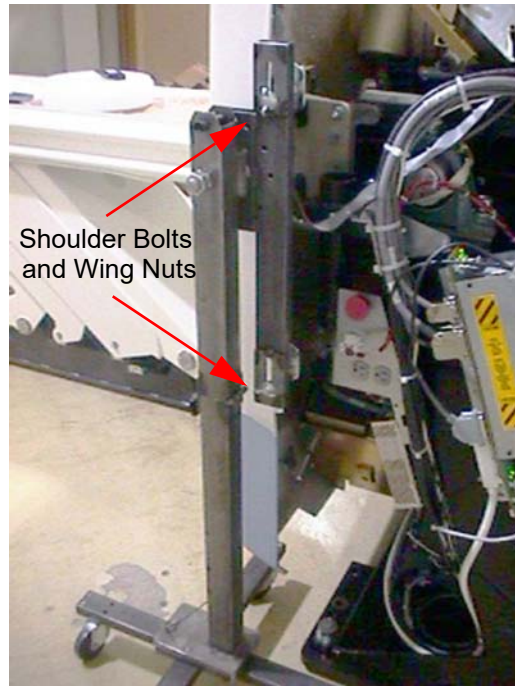


Figure A-12 Front Side Dolly

- b.) Attach side dolly to the shoulder bolts and secure assembly with two (2) wing nuts.
 - c.) Repeat steps a and b to assemble the other side dolly.
- 6.) Detach front cover J1 and J3 and LAN cables.



Figure A-13 Front Cover Cables

- 7.) Remove the Mylar (scan) window.
- 8.) Remove front cover.
 - a.) Disengage upper cantrell bracket on right side of the cover.

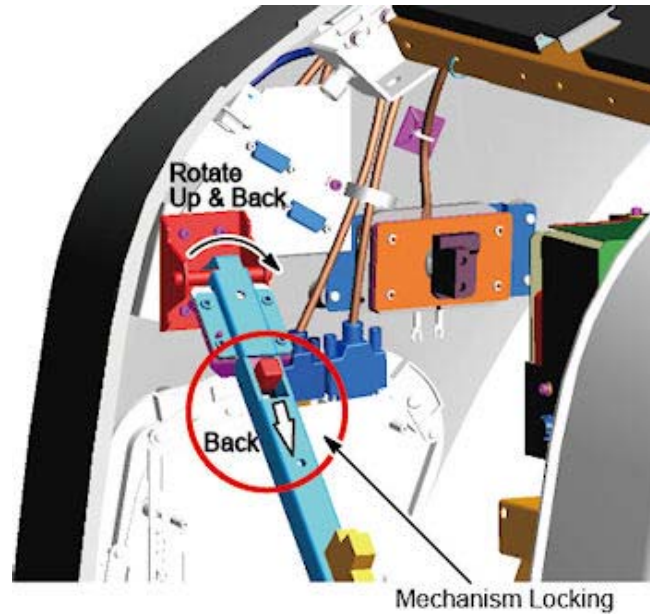


Figure A-14 Releasing Cover Brackets

- A.) Disengage the locking mechanism on the upper cantrell brackets by using your thumb to slide the trigger (red lever) back. This will release the locking mechanism and allow the cantrell to be rotated upwards with steady and firm pressure.
- B.) Disengage the rubber retaining straps on right side. See [Figure A-15](#). You may find it helpful to lift "up" on the cover to align the stud while attaching the rubber retaining straps.

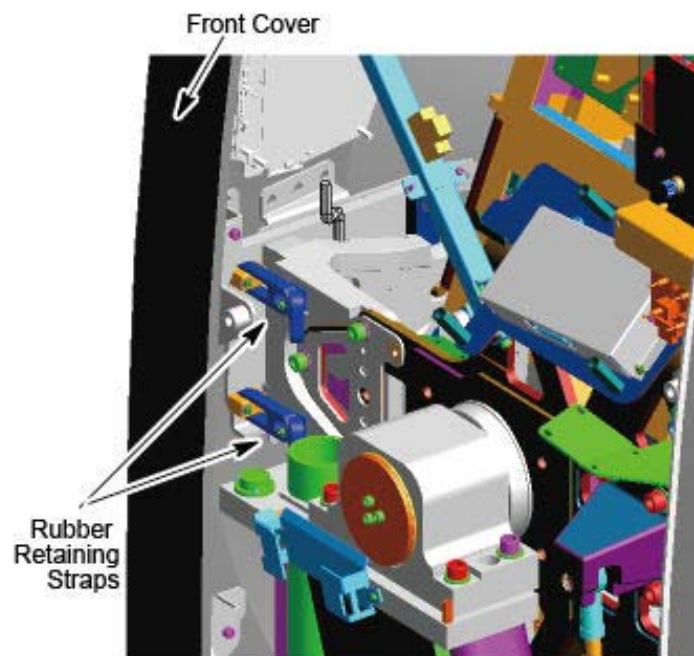


Figure A-15 Rubber Retaining Straps and Cover Locking Mechanism

- b.) Disengage the left side of the front cover.
 - A.) Remove the small cover from the front cover.
 - B.) Loosen M12 screw.

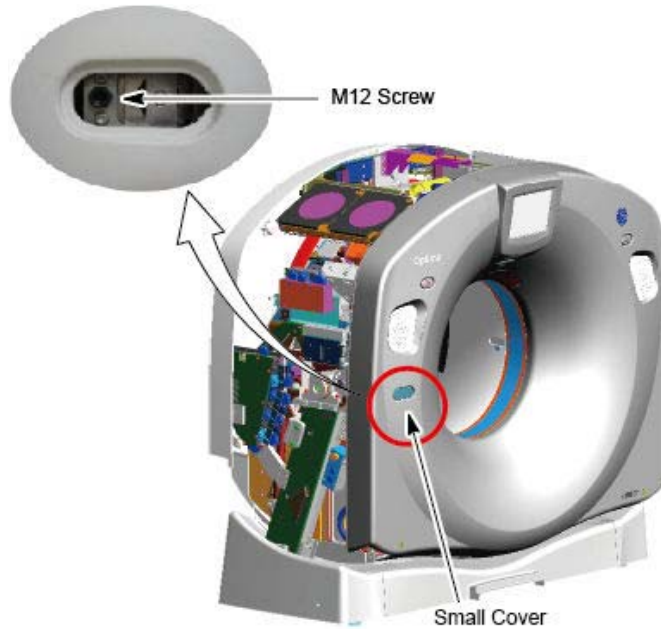


Figure A-16 Disengage the Left Side of the Front Cover

- 9.) Rotate front cover away from gantry.
 - a.) Move front cover away from gantry, leaving space (about 5 feet) between cover and gantry.
 - b.) Pull the locking pin and rotate front cover away from gantry. Place locking pin in one of the side dolly perforations (see [Figure A-17](#)).



Figure A-17 releasing Front Cover Dolly Hinge



1. Upper Left>Rotate cover to make room for step 2.
2. Upper Right>Rotate cover to clear the table. Roll the cover to foot end of table
3. Lower Left> Rotate the cover upside down to provide clear work area.

Note: Remove Gantry Display and Control Panel in position 2.

Figure A-18 Front Cover Removal Sequence

- 10.) Rotate the cover horizontally and move it back and over the table to a safe location. Once in a safe location, you may over-rotate the cover full vertically but upside down.
- 11.) Remove the gantry display from the front cover and place it into its service position if scan is required during maintenance.
 - a.) The gantry display is held in place with (6) thumb screws. Use a flat-blade screwdriver to

remove the Display (see [Figure A-19](#)).

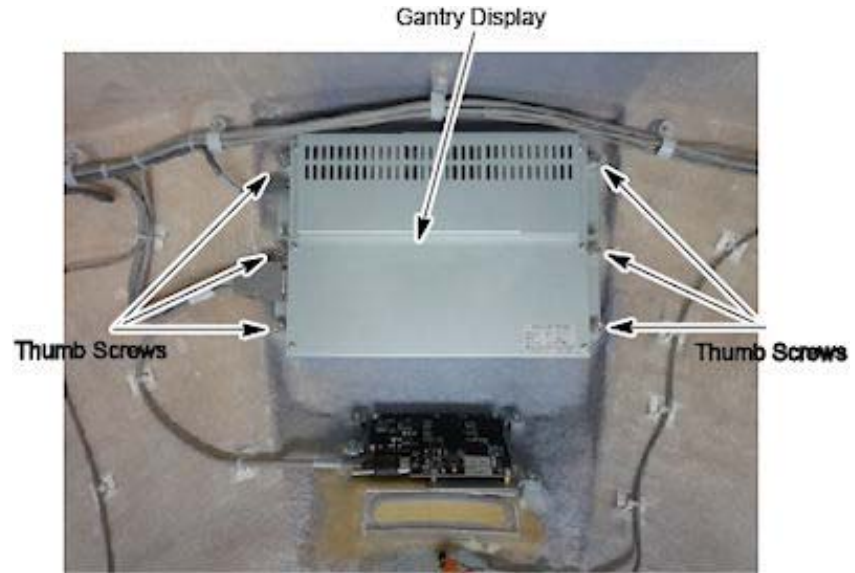


Figure A-19 Gantry Display Removal

b.) Loosen two lock screws of the rear cover.



Figure A-20 Lock Screws of the Rear Cover

c.) Slide the rear cover backward.

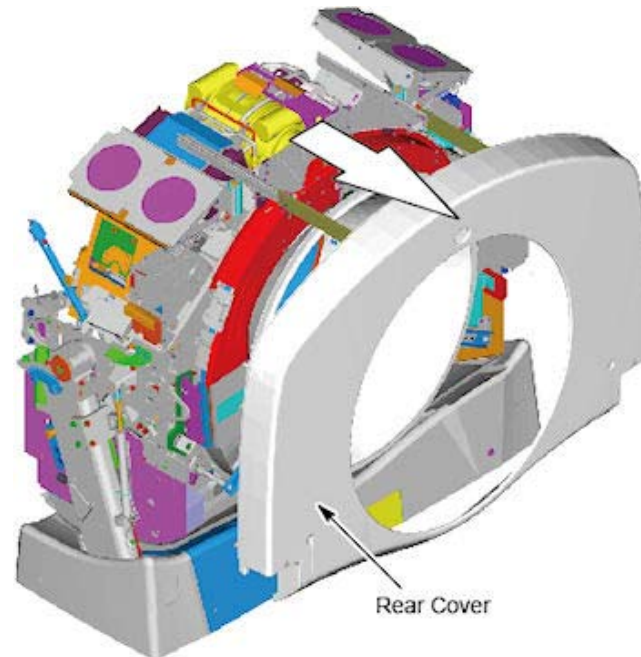


Figure A-21 Rear Cover Slide

d.) Loosen the lock screw of the right top fan of the gantry, and rotate the right top fan.

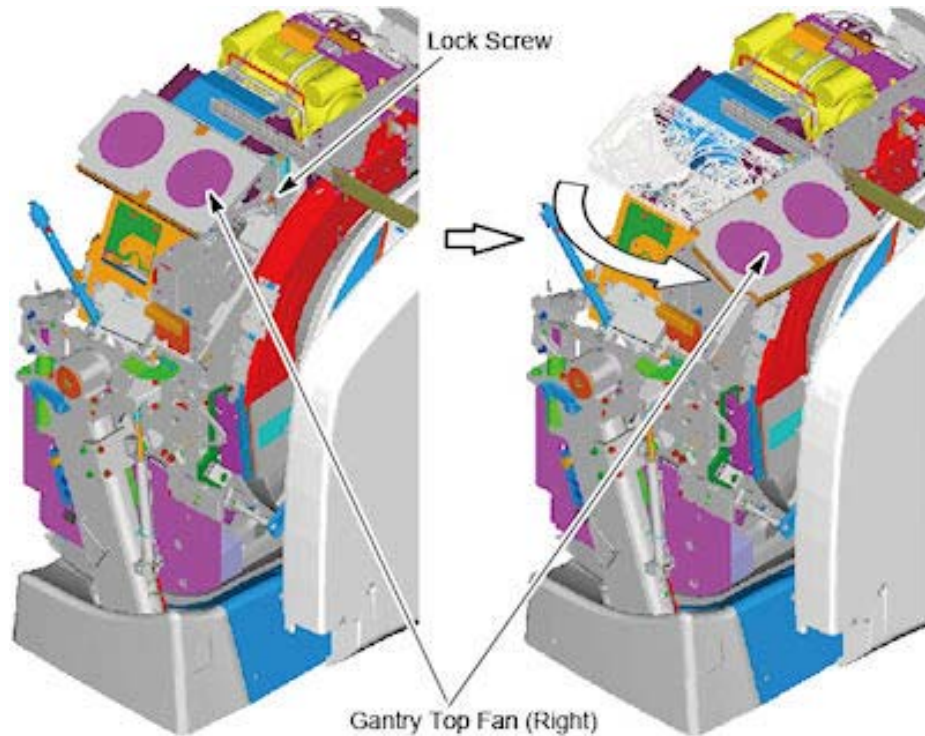


Figure A-22 Top Fan Rotation

- e.) Place the Display in the bracket on the right side of the gantry. (see [Figure A-23](#))



Figure A-23 Gantry Display Service Mounting Location

- 12.) Remove right gantry control assemblies, and place it into its service position.
 - a.) Loose five (5) screws that fasten the control panel to the cover. See [Figure A-24](#). Keep one hand on the control panel at all times to prevent it from dropping to the floor.
 - b.) Set dip switch s19-4 to ON position.



Figure A-24 Dip Switch S19 - 4 Setting

- c.) Align the ball studs with their associated receivers and snap into place.

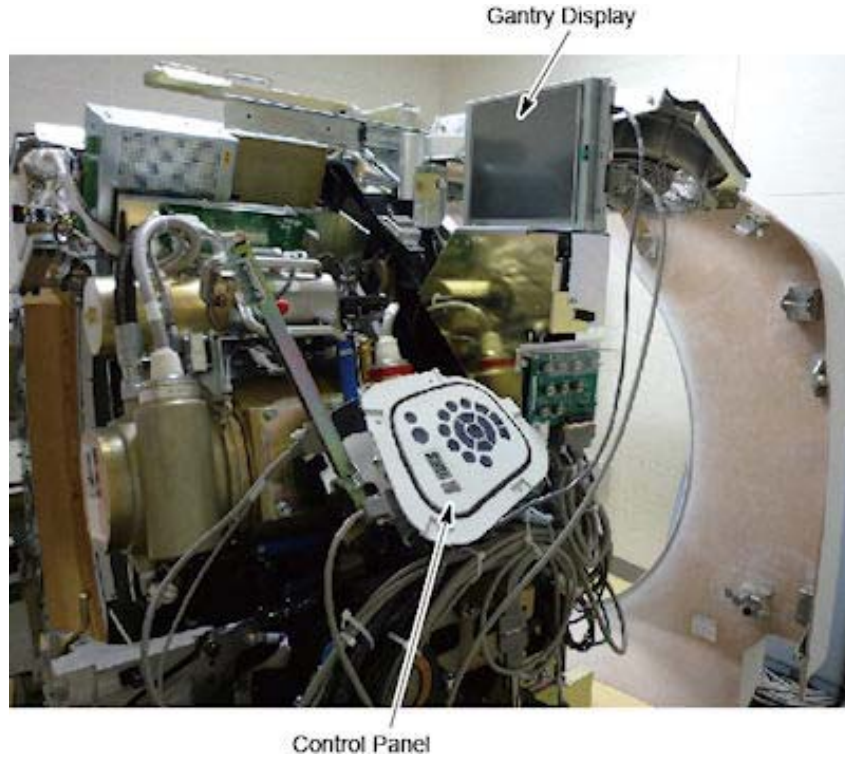


Figure A-25 Control Panel Service Position

- d.) Connect FCVR BKHD J1 cable to terminator located on the cantrell arm. See [Figure A-26](#).

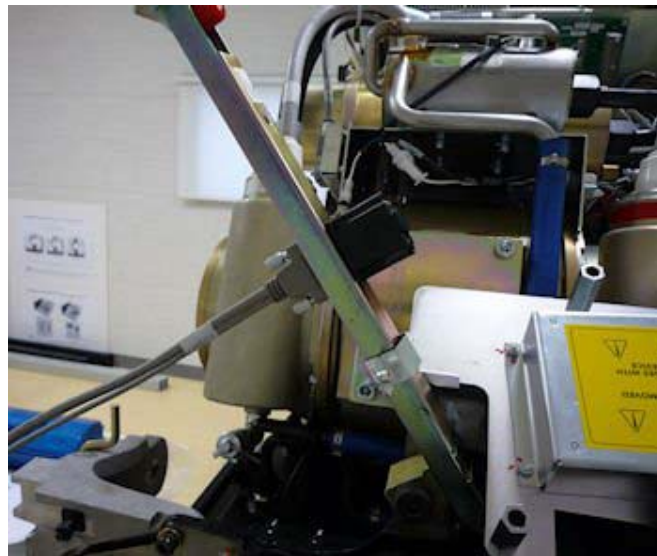


Figure A-26 Gantry Service Mode Cable Terminator

- e.) Connect the FRT CVR J3 cable to the extension cable 5369987 and connect the other

end of the connectors to display and control panel.

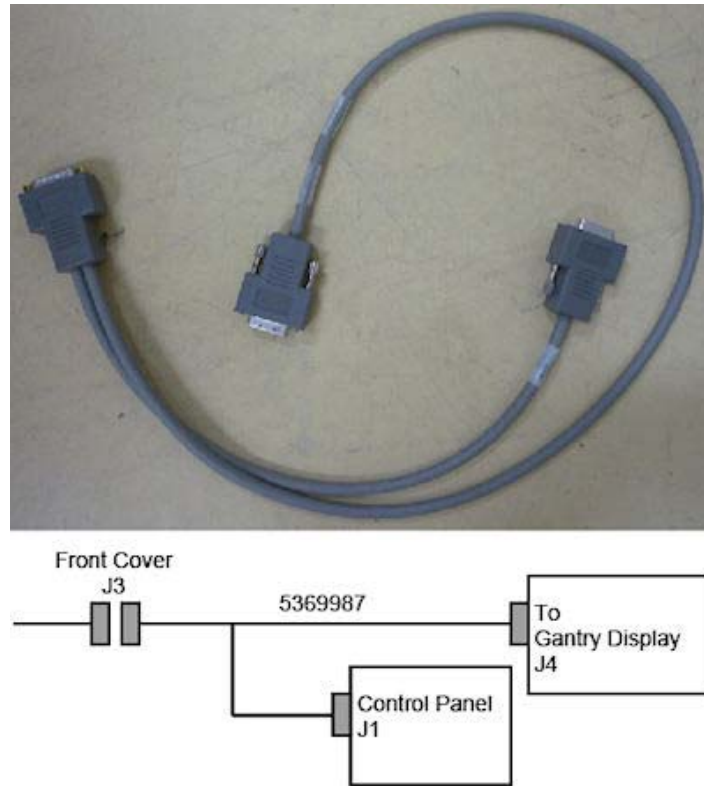


Figure A-27 FRT CVR J3 Cable

1.3.5 Bore Cover Removal

- 1.) Remove gantry side covers, top covers and Mylar window. Refer to each cover's removal procedure.
- 2.) Remove gantry rear and move away from the gantry. Refer to Gantry Rear Cover Removal procedure.
- 3.) Disconnect the Breath Navigator I/F cable and MIC REAR T-SW I/F cable from the top of the bore cover.



Figure A-28 Breath Navigator I/F Cable

- 4.) Remove the 2 screws located at two bottom brackets of the bore cover. Then loosen the screw on top. (Refer to [Figure A-29](#))

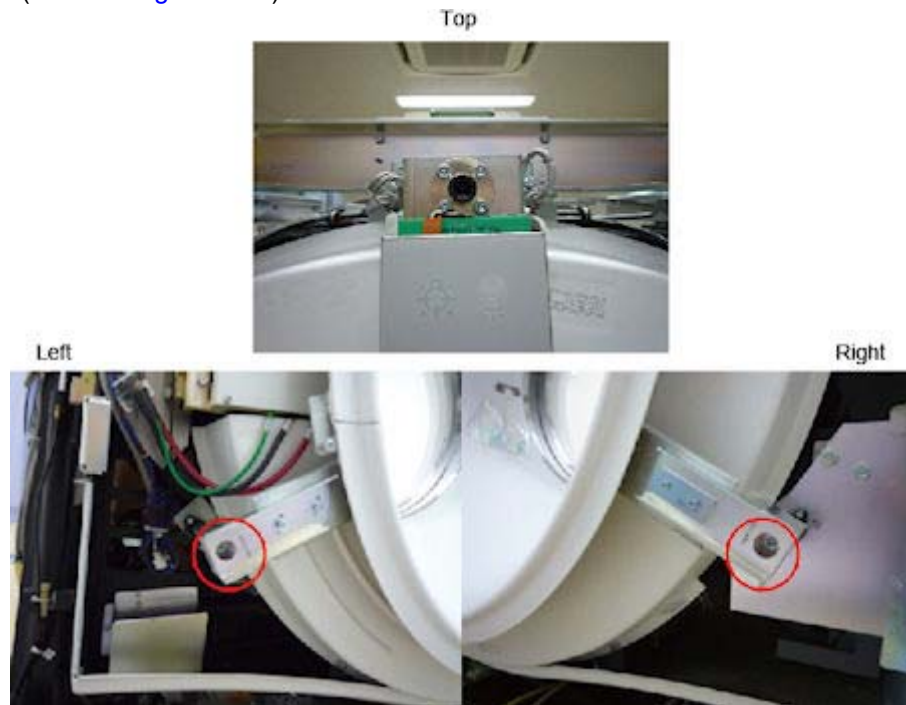


Figure A-29 Screws of Bore Cover

- 5.) Pull up safety pin small knob on the bore cover top bracket and rotate 1/4 turn to keep the safety pin disengaged.



Figure A-30 Safety Pin

- 6.) With two persons, pull out the bore cover from the gantry stationary brackets and place it on the floor.

NOTICE Disable UIF communication after gantry bore cover removal, So if need UIF continuation, please insert the terminal to the Mic/T-SW I/F connector.

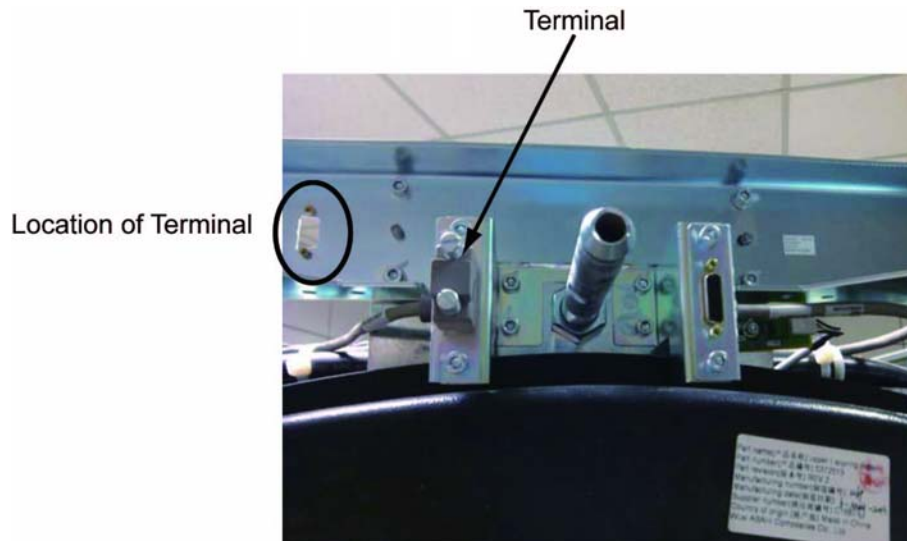


Figure A-31 Location of Terminal

A - Covers

1.3.6 Gantry Rear Cover

Sliding Out Rear Cover

DANGER



ELECTROCUTION HAZARD.

HIGH VOLTAGE PRESENT. POTENTIAL FOR INJURY IF COVERS REMOVED AND POWER IS LEFT "ON".

DISABLE ALL SERVICE SWITCHES PRIOR TO REMOVING REAR COVERS.

NOTICE



Always turn OFF the HVDC before the 120 VAC. Turning OFF 120 VAC power before HVDC power can result in equipment damage.

- 1.) Remove Gantry side covers, top covers and Mylar window.
- 2.) Use a 10mm Hex wrench to unlatch the rear cover.



Figure A-32 Rear Cover Unlatch

- 3.) Slide out the rear cover by pulling the cover backward.



Figure A-33 Rear Cover

Rear Cover Removal

CAUTION



Pinch Hazard
Uncontrolled cover movement
Make sure the wing nuts are tightened on the cover dollies prior to releasing cover from gantry mounts.

- 1.) Install the rear cover dolly.
 - a.) Tighten the two (2) shoulder bolts to the rear cover. Use the extending bolt for the upper side.
 - b.) Fit side dolly through the shoulder bolts and secure assembly with two (2) wing nuts.
 - c.) Repeat steps a and b for the other side dolly.
- 2.) Remove rear cover by removing 8 screws, which attach the rear cover to the brackets.

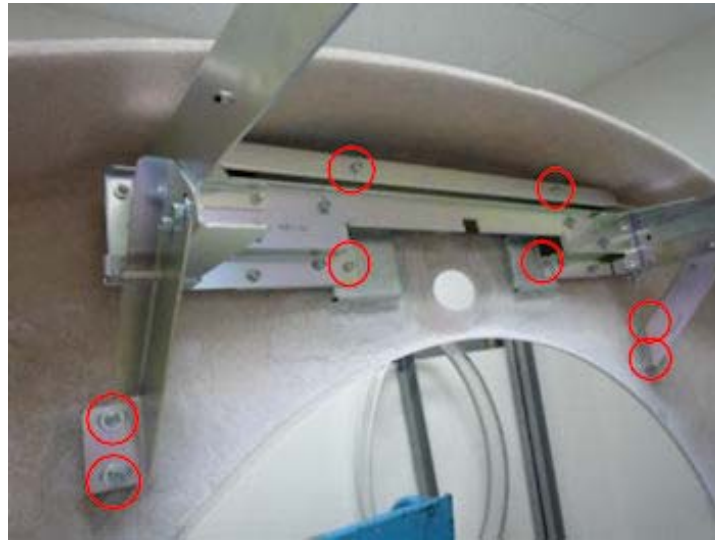


Figure A-34 8 Screws of Rear Cover



Figure A-35 Removed Rear Cover

- 3.) Move cover away from gantry as needed.

This Page Intentionally Blank.

Appendix B

Pictorial Representation of Required Tools

Use the following guide as a reference, if you are unsure of a tool listed in [Section 2.3, on page 27](#).

Table B-1 Required Tools

TOOL NAME	PICTURE	EXAMPLE PART NUMBER*
Adapter		Sears Industrial: 3/8" to 1/2" (9-4258)
Ball-Peen Hammer		Sears Industrial: 1lb/2lb (9-38465)
Canned Air		Miller Stephenson: Aero Duster (MS-222N)
Clamp on Amp Meter		Sears Industrial: 9-WTAD105
Combination Wrench Set		Sears Industrial: U.S. Standard & Metric (9-44048)
Cordless Screwdriver		Sears Industrial: 9-MU65401
Deep Well Socket		Sears Industrial: 3/4" X 3/8" (included with 9-34496)
Dental Pick		
Diagonal Cutting Pliers		Sears Industrial: Small (9-45077)



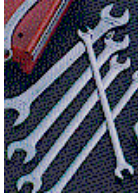







* Part Numbers given for reference only. GE Healthcare does not endorse any tool brand name.

Table B-1 Required Tools (Continued)

TOOL NAME	PICTURE	EXAMPLE PART NUMBER*
Drill		Sears Industrial: $\frac{3}{8}$ " or $\frac{1}{2}$ " (9-27859)
Drill Adapter		Sears Industrial: 3" X $\frac{3}{8}$ " (9-APSZ24)
Drill Bit Set		Sears Industrial: U.S. Standard (9-66084)
DVM		Sears Industrial: 9-82028 Sears Industrial: 9-FL873
Extension for Ratchet Wrench		Sears Industrial: 3" X $\frac{1}{2}$ " (9-44133)
Gloves		Sears Industrial: Large (9-40502)
Hammer Drill		Sears Industrial: $\frac{1}{2}$ " (9-27205)
Hex Bit Set		Sears Industrial: $\frac{1}{4}$ " (9-SK45508)
Hex Key (Allen Wrench) Set		Sears Industrial: U.S. Standard (9-46284)








* Part Numbers given for reference only. GE Healthcare does not endorse any tool brand name.

Table B-1 Required Tools (Continued)

TOOL NAME	PICTURE	EXAMPLE PART NUMBER*
Level		Sears Industrial: 4' (9-39856)
Masonry Bit		
Open-End Wrench (Thin or Standard Tappet)		Snap-on: 10mm (SRSM10) & 21mm (LTAM2124)
Pozi Screwdriver		
Ratchet Wrench		Sears Industrial: 3/8" (9-43175)
Reciprocating Saw with Blades		Sears Industrial: 9-MU650921
Safety Glasses		Sears Industrial: 9-18650
Safety Shoes		
Screwdriver Set		Sears Industrial: Phillips & Straight (9-41505)
Socket Set		Sears Industrial: Standard 3/8" (9-34496)

* Part Numbers given for reference only. GE Healthcare does not endorse any tool brand name.

Table B-1 Required Tools (Continued)

TOOL NAME	PICTURE	EXAMPLE PART NUMBER*
Sockets		Sears Industrial: 1 1/8" X 1/2" (9-47516)
Step Ladder		Sears Industrial: 6' (9-WN6006)
Tongue & Groove Pliers		Sears Industrial: Large (9-CL440)
Torpedo Level		Sears Industrial: 9" (9-39829)
Torque Wrench		Sears Industrial: 3/8" (9-WR3470)
Universal Joint		Sears Industrial: 3/8" (9-4435)
Vacuum Cleaner		Sears Industrial: 8 Gal (9-17780)

* Part Numbers given for reference only. GE Healthcare does not endorse any tool brand name.

Appendix C

Operating Table Installation and Adjustment

Section 1.0 Smart Workspace Table Assembly and Adjustment

This section describe the Smart Workspace table assembly and adjustment procedure

- 1.) Remove all the transportation packaging from the Smart Workspace Table, use the packing material as cushion and carefully put tabletop on it to avoid scratches.
- 2.) Assembly the left and right legs to the tabletop by screwing 4 screws.

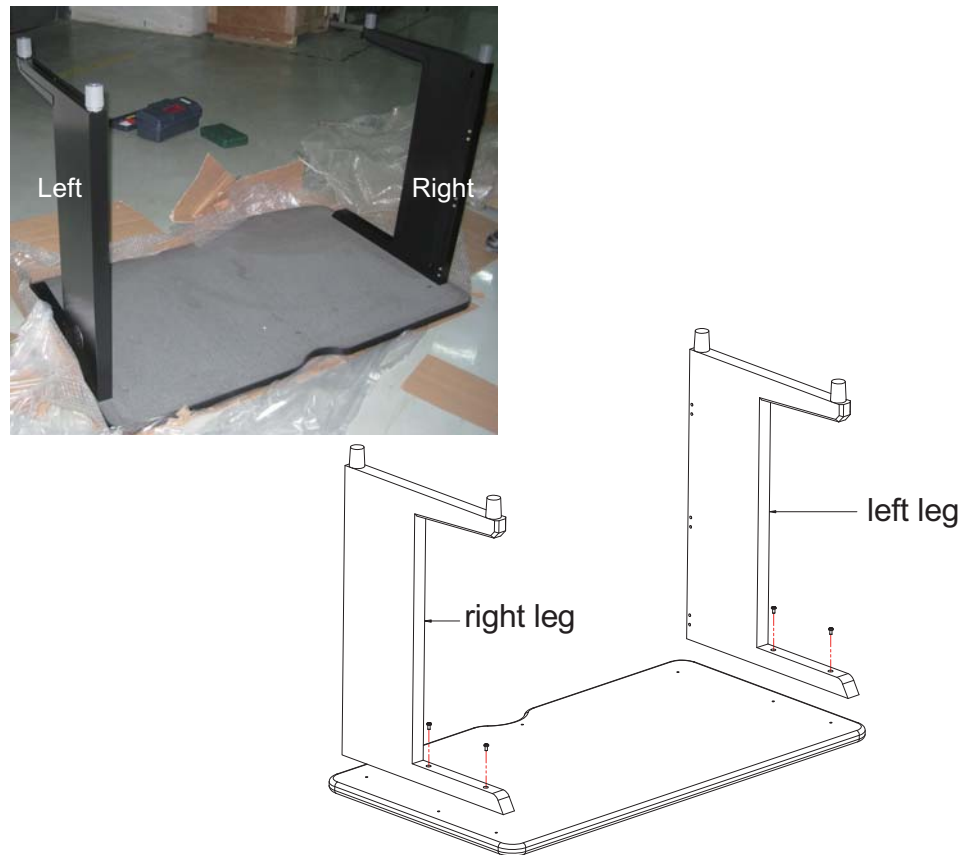


Figure C-1 Table Legs Installation

- 3.) Prepare crossbar and two beams.



Figure C-2 Cross and Beams

- 4.) Install the upper crossbar by screwing seven screws, three screws for tabletop, four screws for left and right legs.



Figure C-3 Crossbar Installation

- 5.) Install two beams to the left and right legs as shown in [Figure C-4](#). Note to keep all screws loose.

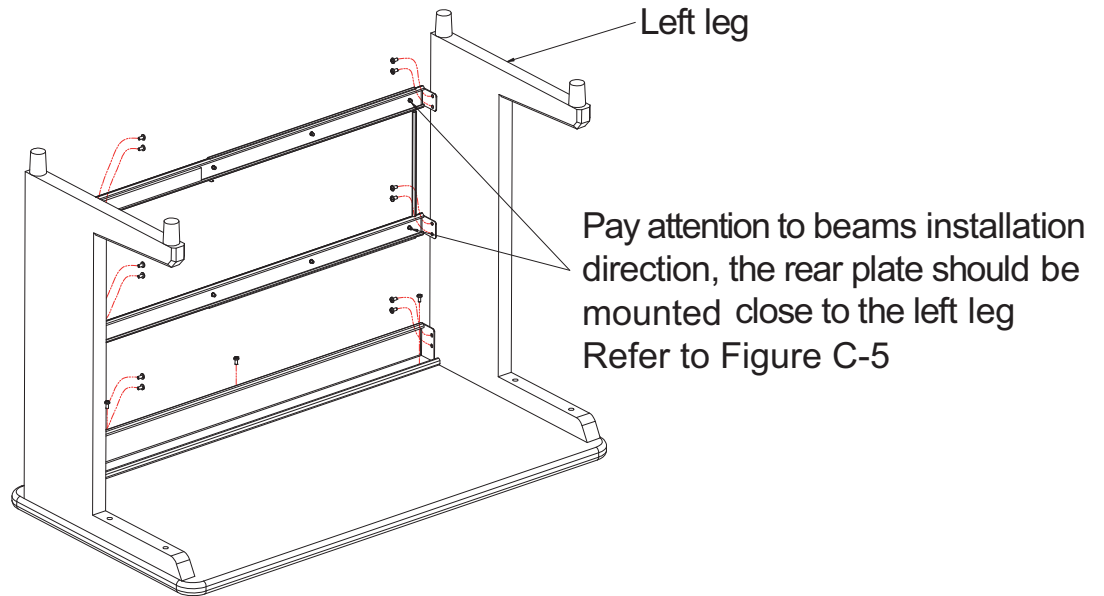


Figure C-4 Beams Installation

- 6.) Mount the rear plate on two beams by screwing 6 screws.

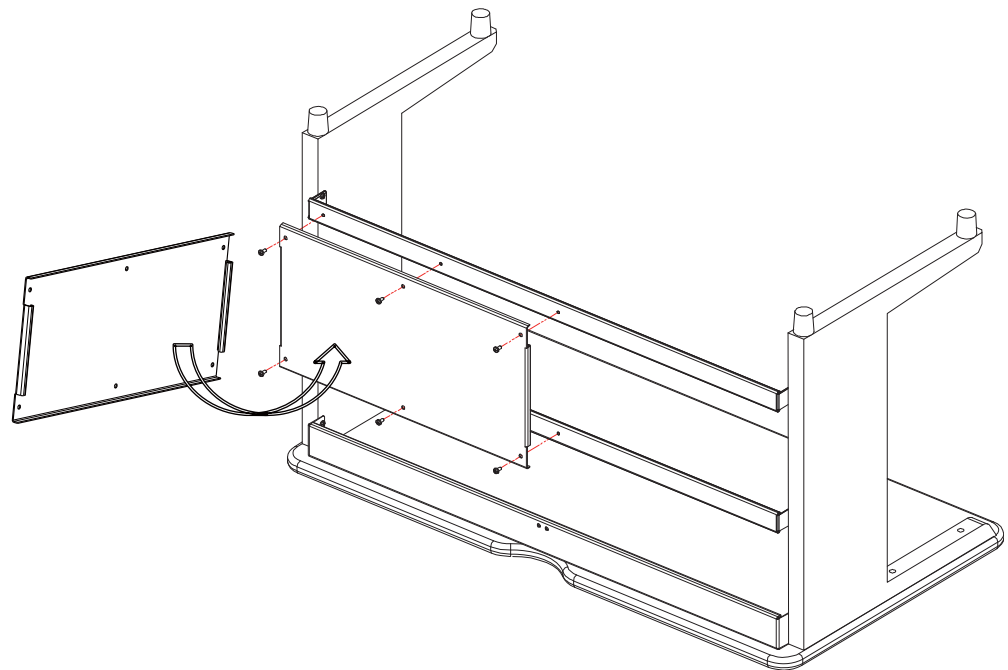


Figure C-5 Rear Plate Installation

- 7.) Tighten all screws.

- 8.) Stick EVA A on the teams and EVA B on the right leg as shown in [Figure C-6](#).

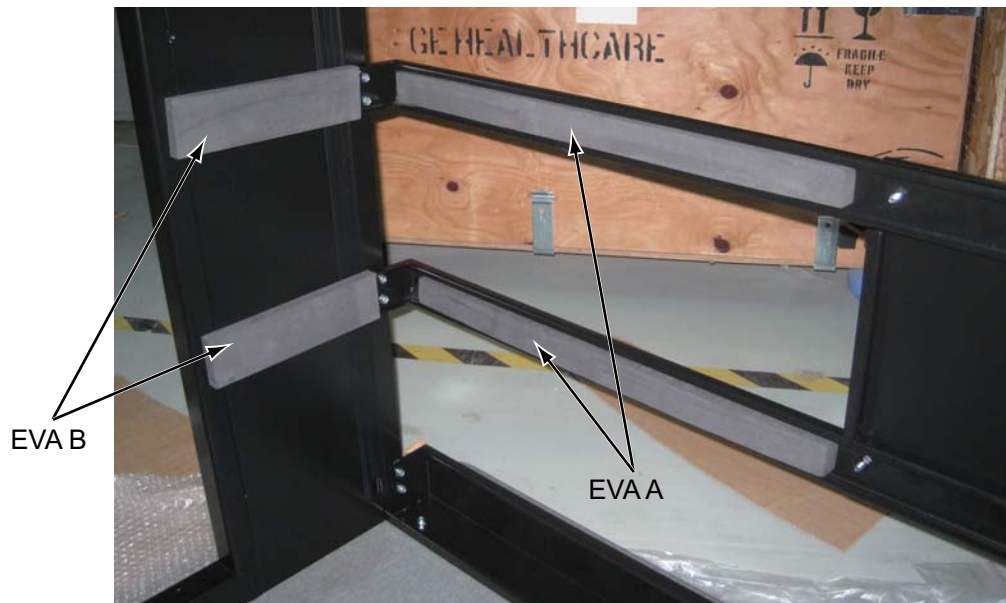


Figure C-6 EVA Attaching

- 9.) Overturn the table, then place monitors and route cables to the table.

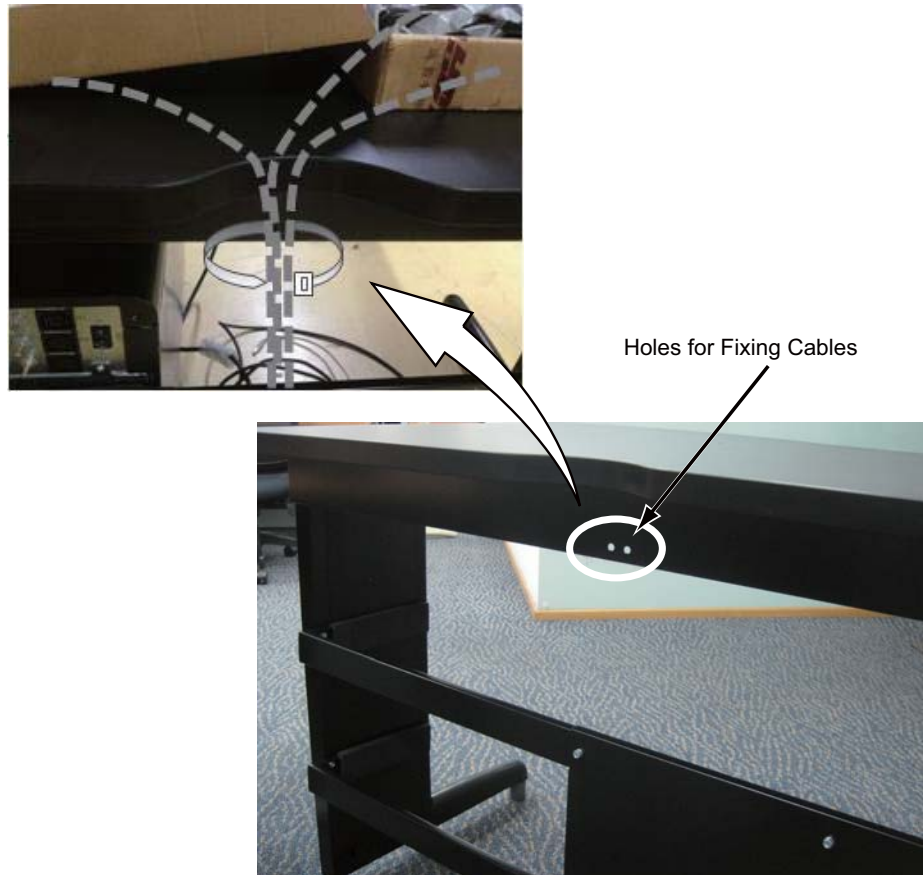


Figure C-7 Route cables to the table

Appendix D

Remote Monitor Option Console Wiring

Section 1.0

NIO Console Remote Monitor Wiring Overview

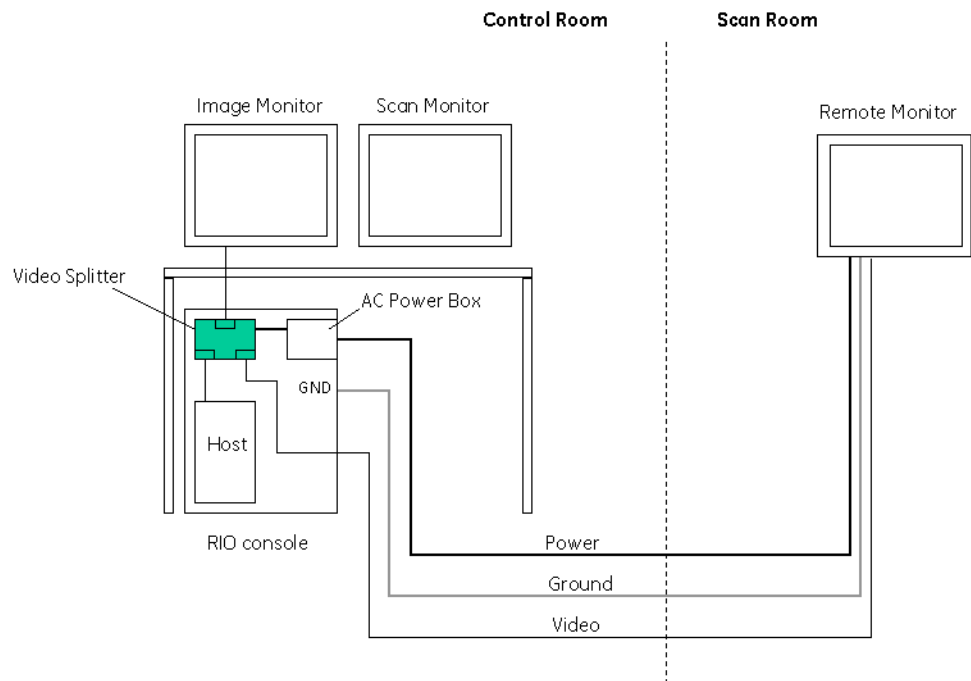


Figure D-1 Remote Monitor Wiring

1.1 Wiring Installation

1.1.1 Power Down System



DANGER ELECTROCUTION HAZARD
HIGH VOLTAGES CAN CAUSE INJURY OR DEATH.
USE PROPER LOCKOUT/TAGOUT PROCEDURES AT THE “MAIN” DISCONNECT BEFORE WORKING ON EQUIPMENT.



CAUTION Do not apply power to the system until all work has been completed and all covers are in their proper place.

Before performing any of the installation procedures described in this section, do the following:

- 1.) After the customer has saved all information: Power down system.
- 2.) Perform LOTO at A1 breaker.
- 3.) Remove the front console cover, using a screwdriver for the two quarter-turn screws located on the console bottom. Screws may differ for your console type.
- 4.) Locate the console power panel.
- 5.) Remove the console back cover if required to install the splitter.

1.1.2 Install 4-Way Splitter

Follow the steps below to install the 4-way splitter.

Figure D-2 shows splitter connections when completed.

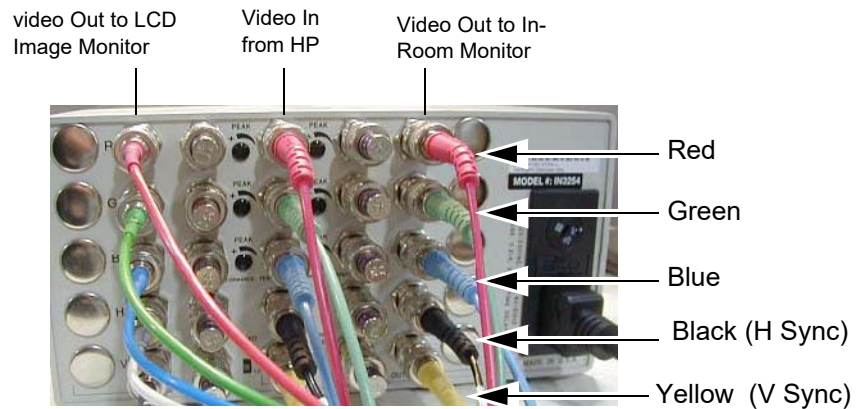


Figure D-2 4-Way Splitter Connections, Completed

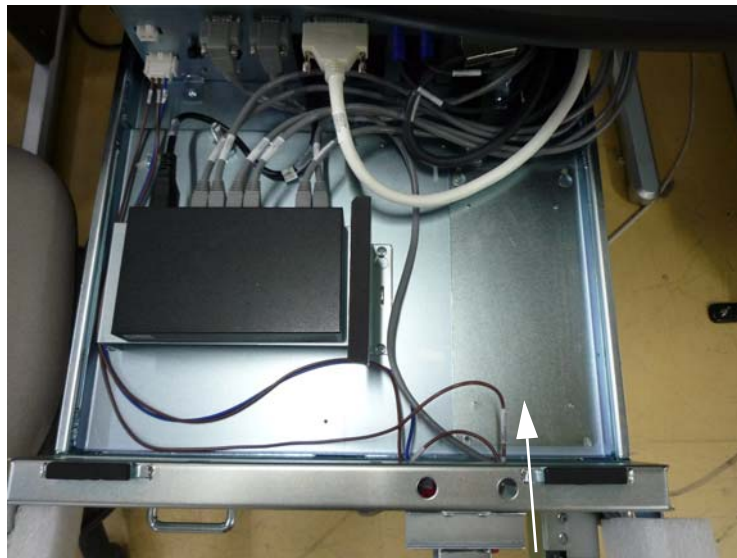
Note: The video cable connections shown in Figure D-2 apply to all 4-way splitters, even if the splitter itself appears different from that shown.

- 1.) Install the splitter:
 - a.) Remove Four rubber legs from the splitter.



Figure D-3 Removing Four Rubber Legs

- b.) Remove the splitter base plate from the console.



Splitter Base Plate

Figure D-4 Removing Splitter Base Plate

c.) Install the base plate to the splitter with the flat head screws.

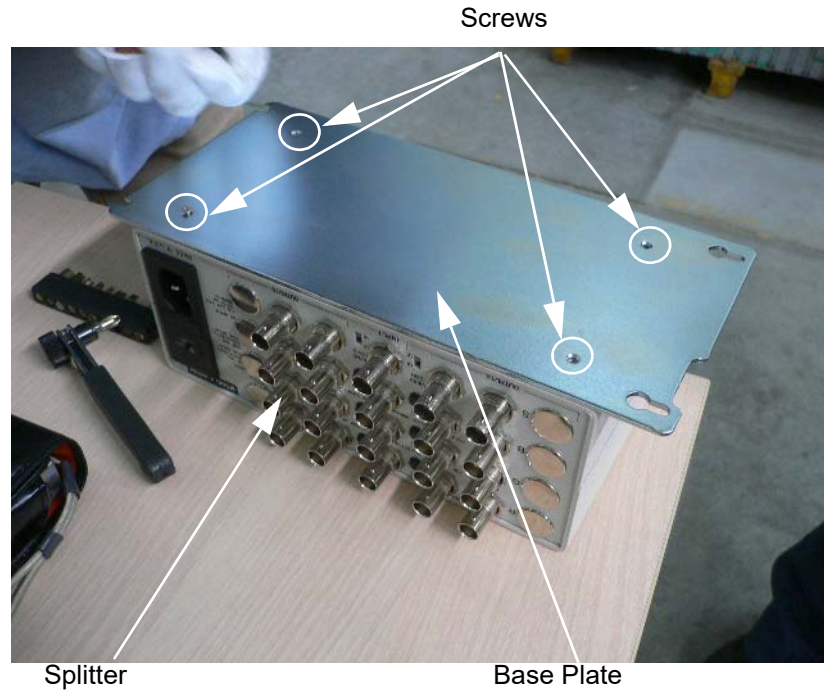


Figure D-5 Installing Base Plate

d.) Install the splitter with the base plate to the console.



Figure D-6 Installing Splitter

- 2.) With the monitor and computer switched off, remove the video cable from the back of the image monitor. See [Figure D-7](#). (The monitor shown below may appear different from the one you have.) Remove this cable from the HP computer video connector. Discard this cable. If the monitor has BNC connectors, remove them.

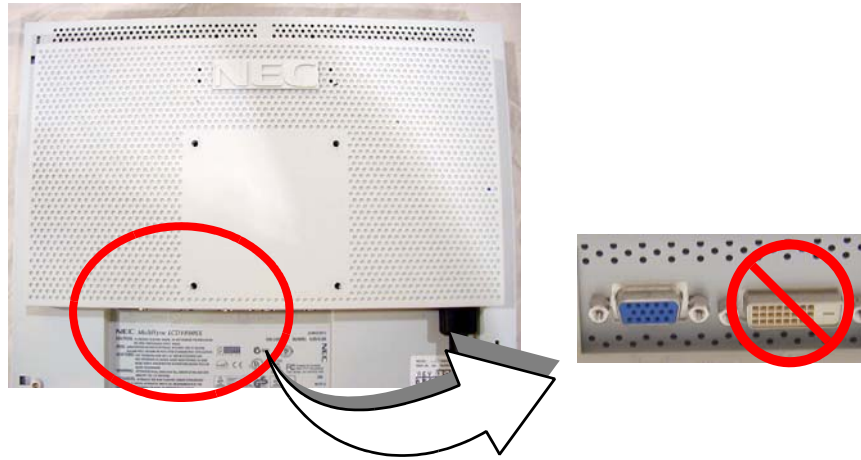


Figure D-7 Image Monitor (Your actual monitor may appear different from picture.)

- 3.) Connect the video cable to the HP computer video connector and then route the cable to the 4-way video splitter.
The kit has the required cable for the connection between the computer and splitter input.
Secure the cable with supplied tie wraps.
- 4.) Route the BNC end of the video cable to the center row of BNC connectors on the video splitter. Use caution when connecting BNC cables. Observe color codes and name on cables.



NOTICE

Potential for Equipment Damage. Touching the video signal cable connector pins may cause them to bend. When connecting the video signal cable, check the alignment of the HD15 connector. Do not force the connector in the wrong way.

- 5.) From the kit, select the second short video cable (the one that has a BNC on one end and HD15 on the other end) and connect this cable between the video splitter and the image monitor.
- 6.) Add the video cables to the video splitter output side. There should be five BNC connectors.
 - a.) Ensure the cables are attached to the video inputs (from above).
 - b.) Attach the cables from the desktop image monitor to the video outputs on the left.
 - c.) Attach the cables from the remote monitor to the video outputs on the right.

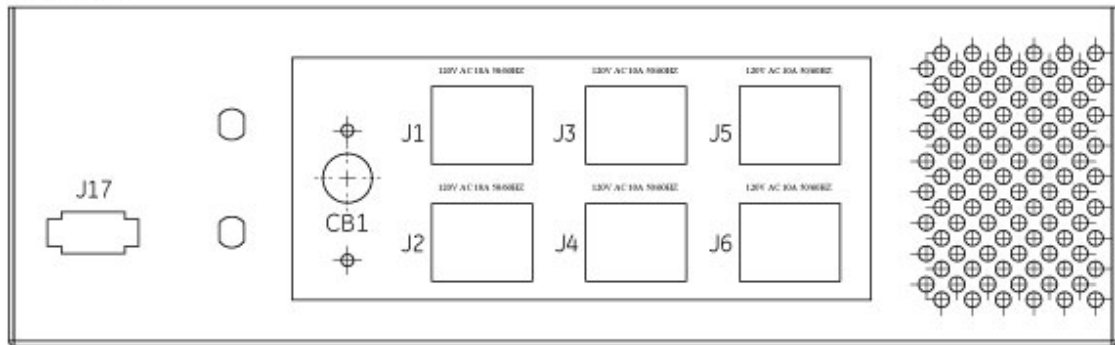
d.) Add BNC terminators to unused outputs.



Figure D-8 Splitter connections

- 7.) Set the Video Gain Level to 1.0 and the Sync Level to HI.
- 8.) Attach the AC power cable from the splitter to the J1 of the console AC Box. See [Figure D-9](#). Connect the remote power cord to J12.

Front View



Rear View

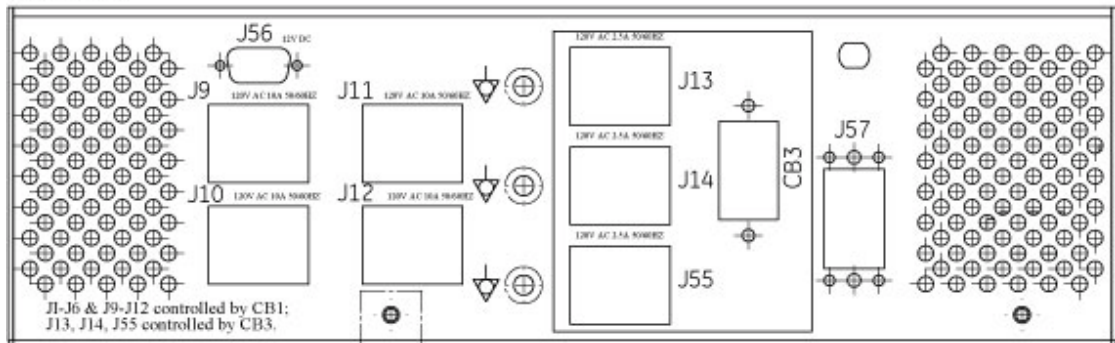


Figure D-9 AC Box J1 and J12

- 9.) Connect one end of the ground wire with the ring terminal to the ground stud on the back of the console.

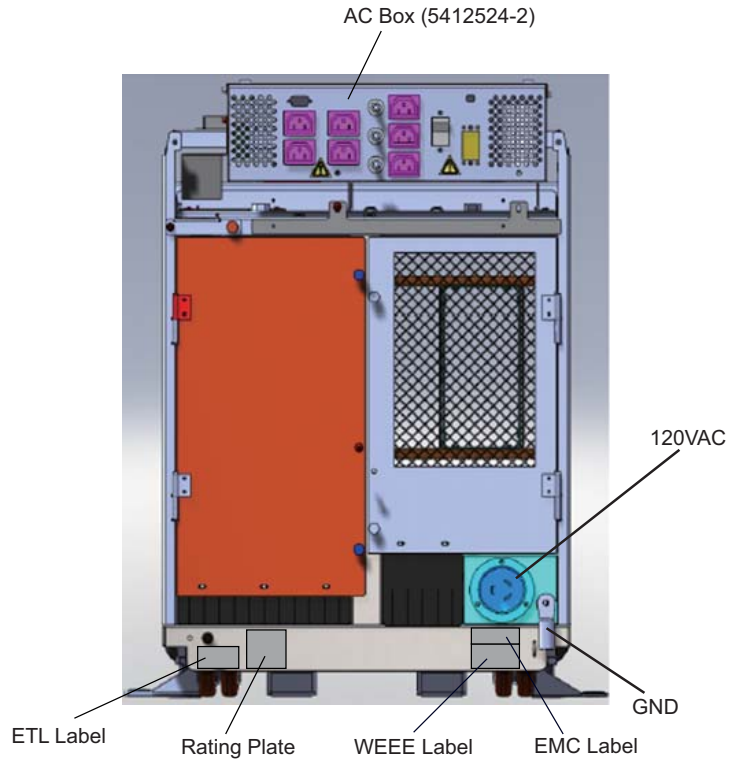


Figure D-10 AC Box Grounds

Section 2.0 Open OC Remote Monitor Wiring Overview

2.1 Remote Monitor Wiring Overview

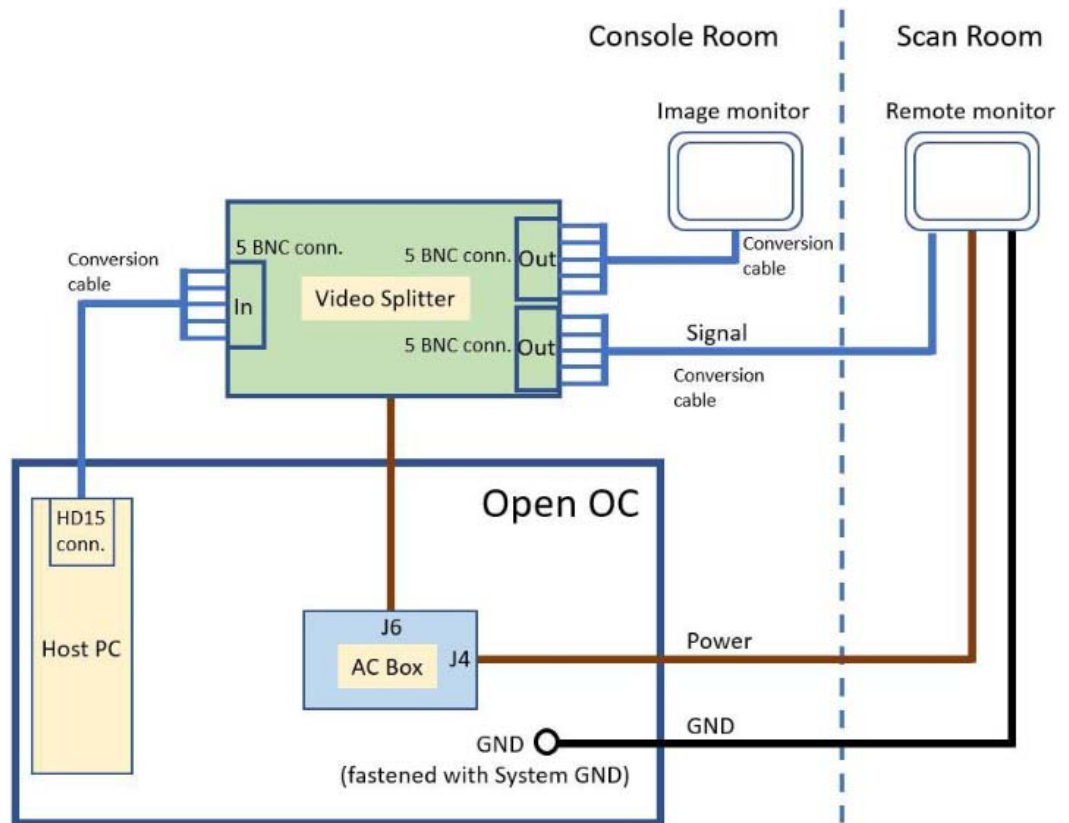


Figure D-11 Remote Monitor Wiring

2.2 Wiring Installation

2.2.1 Power Down System



DANGER ELECTROCUTION HAZARD
HIGH VOLTAGES CAN CAUSE INJURY OR DEATH.
USE PROPER LOCKOUT/TAGOUT PROCEDURES AT THE “MAIN” DISCONNECT BEFORE WORKING ON EQUIPMENT.



CAUTION Do not apply power to the system until all work has been completed and all covers are in their proper place.

Before performing any of the installation procedures described in this section, do the following:

- 1.) After the customer has saved all information: Power down system.
- 2.) Perform LOTO at A1 breaker.

2.2.2 Install 4-Way Splitter

Follow the steps below to install the 4-way splitter.

Figure D-12 shows splitter connections when completed.

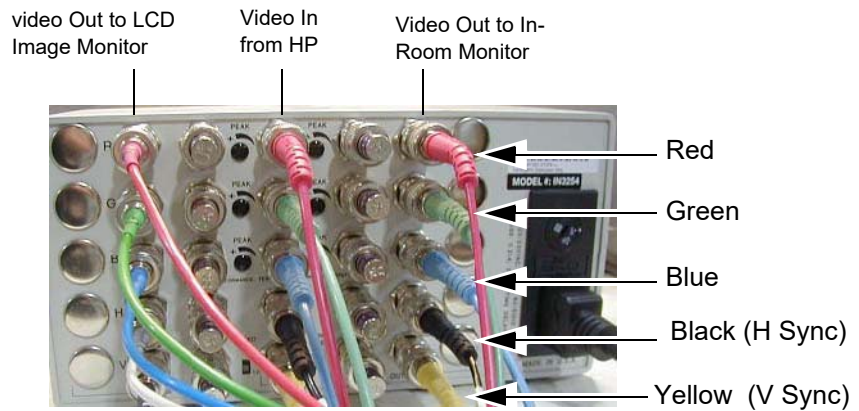


Figure D-12 4-Way Splitter Connections, Completed

Note: The video cable connections shown in Figure D-12 apply to all 4-way splitters, even if the splitter itself appears different from that shown.

- 1.) Put the splitter on the top of the console
- 2.) With the monitor and computer switched off, remove the video cable from the back of the image monitor. See Figure D-13. (The monitor shown below may appear different from the one you have.) Remove this cable from the HP computer video connector. Discard this cable. If the

monitor has BNC connectors, remove them.

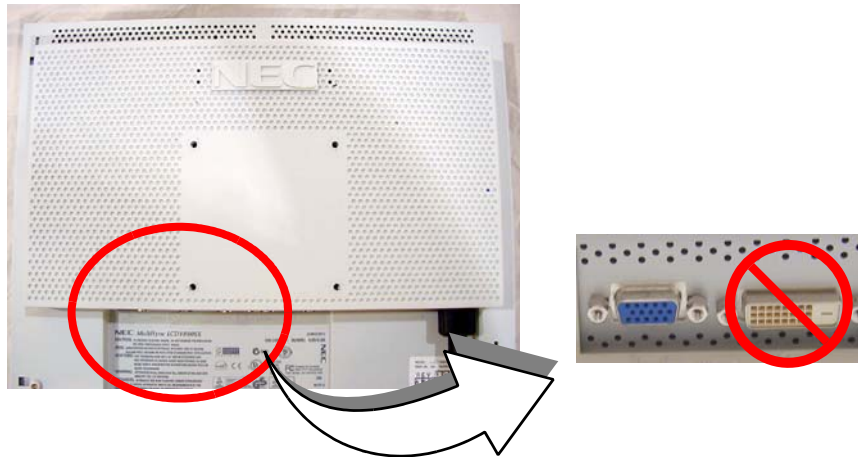


Figure D-13 Image Monitor (Your actual monitor may appear different from picture.)

- 3.) Connect the video cable to the HP computer video connector and then route the cable to the 4-way video splitter.
The kit has the required cable for the connection between the computer and splitter input.
Secure the cable with supplied tie wraps.
- 4.) Route the BNC end of the video cable to the center row of BNC connectors on the video splitter. Use caution when connecting BNC cables. Observe color codes and name on cables.



NOTICE

Potential for Equipment Damage. Touching the video signal cable connector pins may cause them to bend. When connecting the video signal cable, check the alignment of the HD15 connector. Do not force the connector in the wrong way.

- 5.) From the kit, select the second short video cable (the one that has a BNC on one end and HD15 on the other end) and connect this cable between the video splitter and the image monitor.
- 6.) Add the video cables to the video splitter output side. There should be five BNC connectors.
 - a.) Ensure the cables are attached to the video inputs (from above).
 - b.) Attach the cables from the desktop image monitor to the video outputs on the left.
 - c.) Attach the cables from the remote monitor to the video outputs on the right.

d.) Add BNC terminators to unused outputs.



Figure D-14 Splitter connections

- 7.) Set the Video Gain Level to 1.0 and the Sync Level to HI.
- 8.) Attach the AC power cable from the splitter to the J6 of the console AC Box. See [Figure D-15](#). Connect the remote power cord to J4.

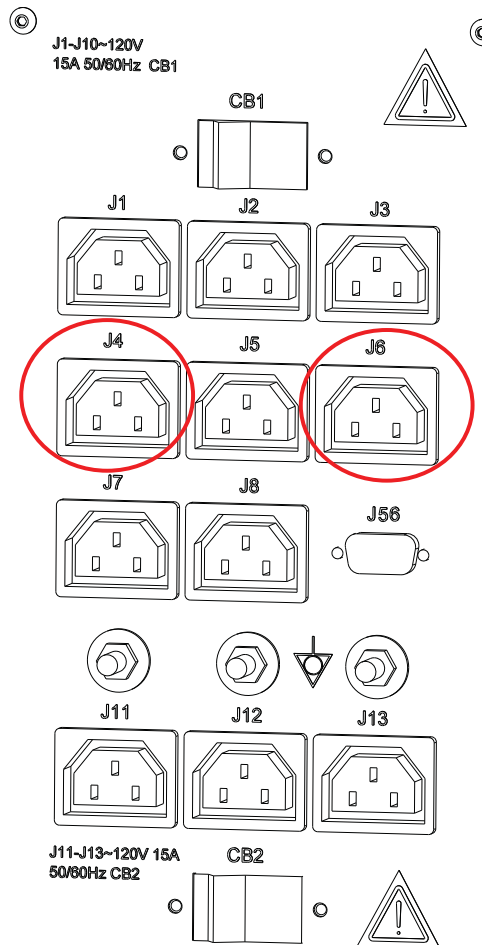


Figure D-15 AC Box J4 and J6

- 9.) Connect one end of the ground wire with the ring terminal to the ground stud on the back of the console.

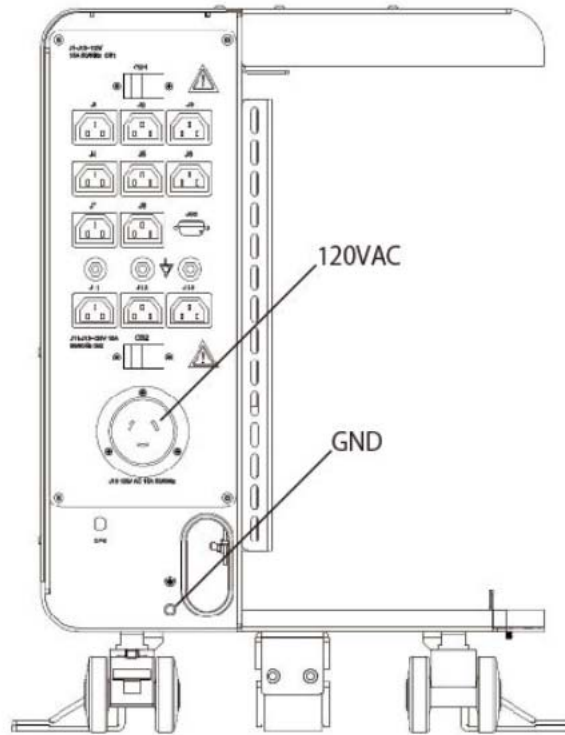


Figure D-16 Open OC AC Power and Ground

www.gehealthcare.com

