

REV.	ZONE	DESCRIPTION	DATE	REV. BY	DR.	ELEC ENG	MECH ENG
1	F-8	Add physical ID	Sep/25/2017	Odagiri	ARIYAMA		
1	F-8	Add physical ID	Aug/25/2017	Odagiri	KOBAYASHI		
					YAMADA		

**STATIONARY SIDE**

**CJ3/KL64 GANTRY INTERCONNECT**

5454001-30 SCH 2

(\*) Option Parts

SIZE A3

技術部

State: RELEASE - Document is released and under formal Change Control. Changes are subject to the ECR/ECO Process. See the GEHC Myworkshop System to determine the status of this document.

State: RELEASE - Document is released and under formal Change Control. Changes are subject to the ECR/ECO Process.  
 See the GEHC Myworkshop System to determine the status of this document.

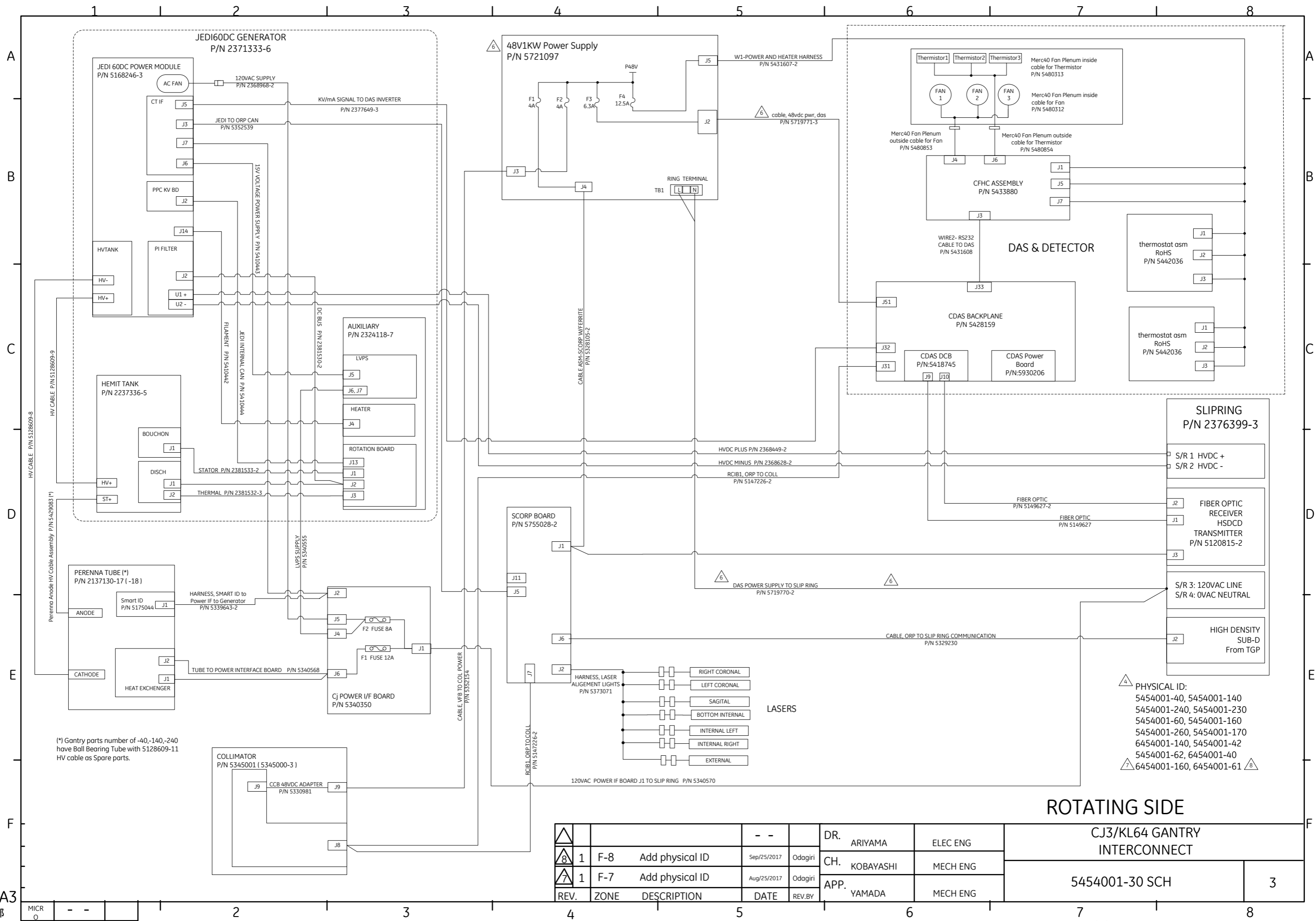

- △ PHYSICAL ID:  
 5454001-40, 5454001-140  
 5454001-240, 5454001-230  
 5454001-60, 5454001-160  
 5454001-260, 5454001-170  
 6454001-140, 5454001-42  
 5454001-62, 6454001-40  
 △ 6454001-160, 6454001-61 △ 8

REV.	ZONE	DESCRIPTION	DATE	REV. BY	DR.	ELEC ENG	CJ3/KL64 GANTRY INTERCONNECT	
1	F-8	Add physical ID	Sep/25/2017	Odagiri	ARIYAMA	ELEC ENG	5454001-30 SCH	
1	F-7	Add physical ID	Aug/25/2017	Odagiri	KOBAYASHI	MECH ENG		
					YAMADA	MECH ENG		

